

Industrial Technology

Timber Products and Furniture Technologies

General Instructions

- Reading time – 5 minutes
- Working time – 1½ hours
- Write using black pen
- Draw diagrams using pencil
- Board-approved calculators may be used
- Write your Centre Number and Student Number at the top of page 5

Total marks – 40

Section I Pages 2–4

10 marks

- Attempt Questions 1–10
- Allow about 20 minutes for this section

Section II Pages 5–7

15 marks

- Attempt Questions 11–15
- Allow about 35 minutes for this section

Section III Page 9

15 marks

- Attempt Question 16
- Allow about 35 minutes for this section

Section I

10 marks

Attempt Questions 1–10

Allow about 20 minutes for this section

Use the multiple-choice answer sheet for Questions 1–10.

1 What is the purpose of the kerf on a saw blade?

- (A) To remove waste material
- (B) To reduce noise when cutting
- (C) To prevent the blade jamming
- (D) To reduce vibration when cutting

2

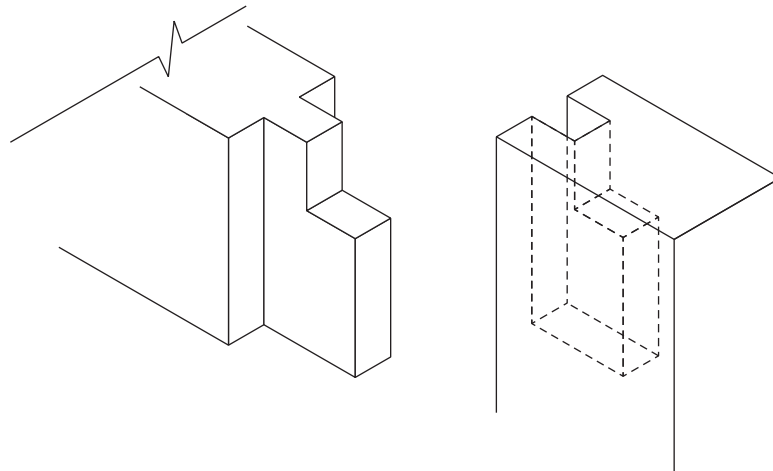

What type of mortise and tenon joint is shown?

- (A) Wedged
 - (B) Through
 - (C) Haunched
 - (D) Long and short shouldered
- 3 Which of the following adhesives would be the LEAST suitable for application in outdoor furniture?
- (A) PVA
 - (B) Epoxy resin
 - (C) Urea formaldehyde
 - (D) Resorcinol formaldehyde

- 4 In the conversion and preparation of timber, what does *ripping* refer to?
- (A) Cutting to length
 - (B) Cutting along the grain
 - (C) Cutting across the grain
 - (D) Cutting at any compound angle
- 5 Which of the following processes is *honing*?
- (A) Setting the teeth on a handsaw to create the kerf
 - (B) Sharpening of a scraper with a hardened steel rod
 - (C) Using a whetstone to finish sharpening of a tool blade
 - (D) Removing fine timber shavings with a hardened plate
- 6 What is the main advantage of air seasoning over kiln seasoning of timber?
- (A) Faster removal of moisture content
 - (B) Reduced expense due to lower energy input
 - (C) Increased control over final moisture content
 - (D) Increased stability due to slower moisture removal
- 7 What is the purpose of the ridges on the underside of a countersunk head chipboard screw?



- (A) To remove the need to pre-countersink the hole
- (B) To bind into the timber surface to prevent splitting
- (C) To slow the screw entry to avoid stripping the thread
- (D) To strengthen the screw head to allow removal and reuse

- 8** For which of the following would it be best to use a bandsaw blade with a high tooth per inch count and a thin width?
- (A) Fast cutting of stock
 - (B) Ripping thick sections
 - (C) Cutting round stock safely
 - (D) Cutting curves and thin stock
- 9** Which of the following lists three methods that can be used in the cutting of veneers?
- (A) Quarter slicing, rift slicing and back sawing
 - (B) Rift slicing, quarter slicing and rotary peeling
 - (C) Live sawing, quarter slicing and rotary peeling
 - (D) Rotary peeling, tangential sawing and rift slicing
- 10** Why should grain direction be considered before thicknessing?
- (A) To improve cutting speed
 - (B) To reduce wear on the blades
 - (C) To minimise tearing of the grain
 - (D) To reduce the noise of cutting operations

Industrial Technology
Timber Products and Furniture
Technologies

--	--	--	--	--

Centre Number

--	--	--	--	--	--	--	--	--

Student Number

Section II

15 marks

Attempt Questions 11–15

Allow about 35 minutes for this section

Answer the questions in the spaces provided. These spaces provide guidance for the expected length of response.

Question 11 (1 mark)

What is a purpose of dry cramping?

1

.....

.....

Question 12 (3 marks)

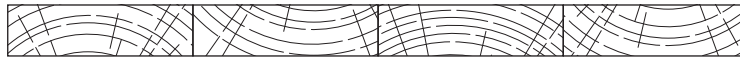

Explain why the growth rings on the widening jointed boards shown are alternated.

3

.....

.....

.....

.....

.....

.....

.....

.....

Question 13 (3 marks)

New hardware and fittings have made traditional timber joints obsolete in some areas.

3

Name an alternative joining technique and outline TWO advantages that it has over traditional techniques.

.....
.....
.....
.....
.....
.....
.....
.....

Question 14 (3 marks)

Why would a cabinet-maker use quarter-sawn timber when making fine quality furniture?

3

.....
.....
.....
.....
.....
.....
.....
.....

Question 15 (5 marks)

Describe the steps used to produce the laminated veneer stool shown.

5

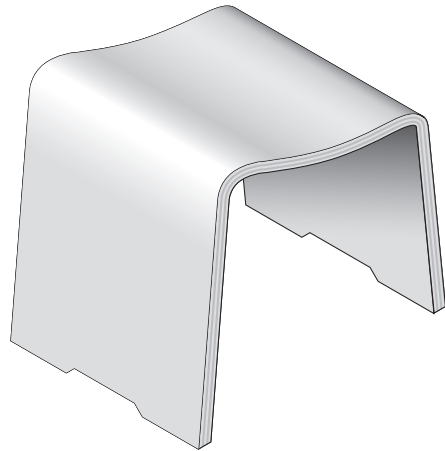

.....

.....

.....

.....

.....

.....

.....

.....

.....

.....

.....

.....

.....

.....

.....

.....

.....

.....

.....

.....

.....

.....

.....

.....

BLANK PAGE

Industrial Technology

Timber Products and Furniture Technologies

Section III

15 marks

Attempt Question 16

Allow about 35 minutes for this section

Answer part (a) of the question in a writing booklet. Answer part (b) of the question in a SEPARATE writing booklet. Extra writing booklets are available.

Question 16 (15 marks)

Answer part (a) of the question in a writing booklet.

- (a) Explain how restructuring a business can affect quality control. **5**

Answer part (b) of the question in a SEPARATE writing booklet.

- (b) Assess the effect of new technology on production and efficiency in the timber products and furniture industry. **10**

End of paper

BLANK PAGE