

B O A R D O F S T U D I E S
NEW SOUTH WALES

2006

**HIGHER SCHOOL CERTIFICATE
EXAMINATION**

General Mathematics

General Instructions

- Reading time – 5 minutes
- Working time – $2\frac{1}{2}$ hours
- Write using black or blue pen
- Calculators may be used
- A formulae sheet is provided at the back of this paper

Total marks – 100

Section I Pages 2–10

22 marks

- Attempt Questions 1–22
- Allow about 30 minutes for this section

Section II Pages 11–23

78 marks

- Attempt Questions 23–28
- Allow about 2 hours for this section

Section I

22 marks

Attempt Questions 1–22

Allow about 30 minutes for this section

Use the multiple-choice answer sheet.

Select the alternative A, B, C or D that best answers the question. Fill in the response oval completely.

Sample: $2 + 4 =$ (A) 2 (B) 6 (C) 8 (D) 9
A B C D

If you think you have made a mistake, put a cross through the incorrect answer and fill in the new answer.

A B C D

If you change your mind and have crossed out what you consider to be the correct answer, then indicate the correct answer by writing the word **correct** and drawing an arrow as follows.

A B C D
correct
↙

- 1 The probability of an event occurring is $\frac{9}{10}$.

Which statement best describes the probability of this event occurring?

- (A) The event is likely to occur.
(B) The event is certain to occur.
(C) The event is unlikely to occur.
(D) The event has an even chance of occurring.
- 2 If $V = \frac{4}{3}\pi r^3$, what is the value of V when $r = 2$, correct to two decimal places?
- (A) 8.38
(B) 12.57
(C) 25.13
(D) 33.51
- 3 The angle of depression of the base of the tree from the top of the building is 65° . The height of the building is 30 m.

How far away is the base of the tree from the building, correct to one decimal place?

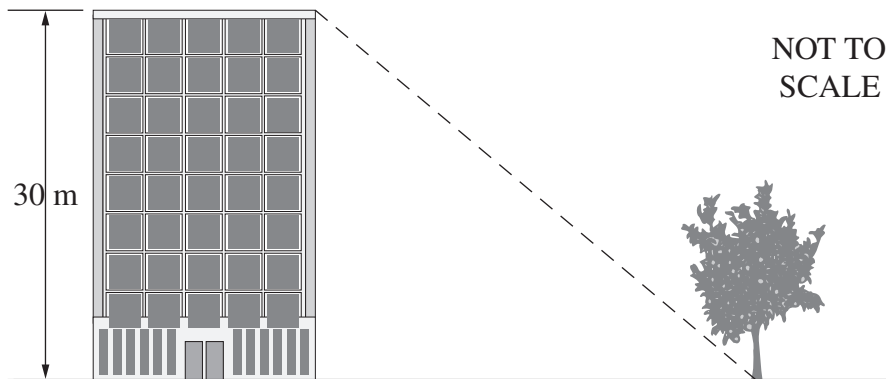

- (A) 12.7 m
(B) 14.0 m
(C) 33.1 m
(D) 64.3 m

- 4 A set of scores is displayed in a stem-and-leaf plot.

1	2 2 3
2	5 8
3	8 9
4	1 3 9

What is the median of this set of scores?

- (A) 28
(B) 30
(C) 33
(D) 47
- 5 A salesman earns \$200 per week plus \$40 commission for each item he sells.

How many items does he need to sell to earn a total of \$2640 in two weeks?

- (A) 33
(B) 56
(C) 61
(D) 66
- 6 Marcella is planning to roll a standard six-sided die 60 times.

How many times would she expect to roll the number 4?

- (A) 6
(B) 10
(C) 15
(D) 20

7 Which equation represents the relationship between x and y in this table?

x	0	2	4	6	8
y	1	2	3	4	5

(A) $y = 2x + 1$

(B) $y = 2x - 2$

(C) $y = \frac{x}{2} - 2$

(D) $y = \frac{x}{2} + 1$

8 Which of these graphs best represents positively skewed data with the smaller standard deviation?

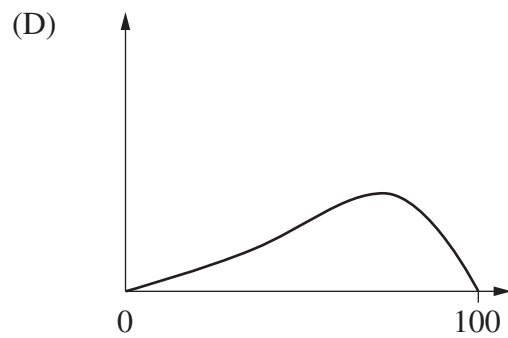
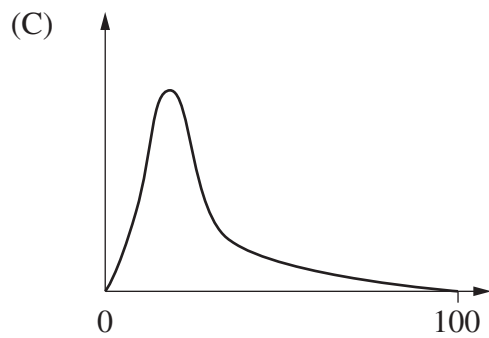
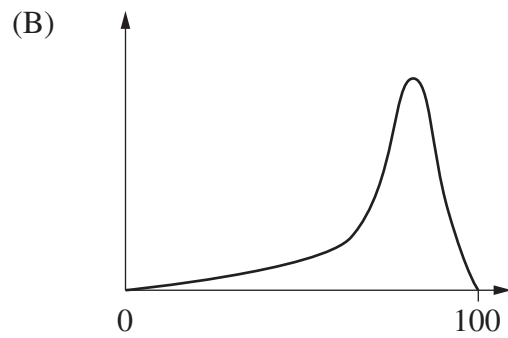
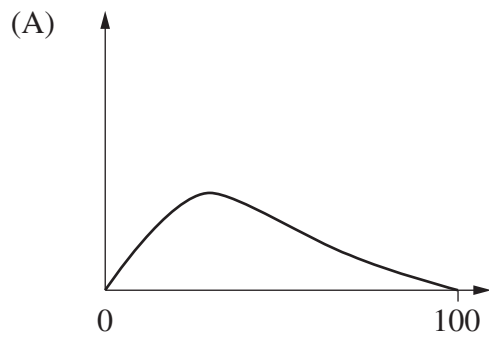

- 9 What is the area of this triangle, to the nearest square metre?

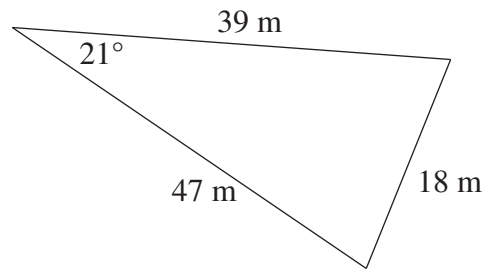

NOT
TO
SCALE

- (A) 152 m²
(B) 283 m²
(C) 328 m²
(D) 351 m²
- 10 Kay randomly selected a marble from a bag of marbles, recorded its colour and returned it to the bag. She repeated this process a number of times.

<i>Colour</i>	<i>Tally</i>	<i>Frequency</i>
Red	 	7
Blue		3
Yellow		2
Green		4
Purple	 	8

Based on these results, what is the best estimate of the probability that Kay will choose a green marble on her next selection?

- (A) $\frac{5}{24}$
(B) $\frac{1}{24}$
(C) $\frac{1}{6}$
(D) $\frac{1}{5}$

11 Peter rides his bike at a speed of 27 km/h.

What is this speed in m/s?

- (A) 7.5
- (B) 18.75
- (C) 97.2
- (D) 450

12 The mean of a set of 5 scores is 62.

What is the new mean of the set of scores after a score of 14 is added?

- (A) 38
- (B) 54
- (C) 62
- (D) 76

13 What is the bearing of A from B?

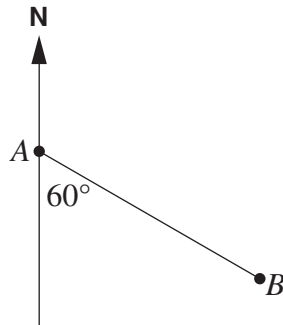

- (A) 060°
- (B) 120°
- (C) 150°
- (D) 300°

- 14 In 2004 there were 13.5 million registered motor vehicles in Australia. The number of registered motor vehicles is increasing at a rate of 2.3% per year.

Which expression represents the number (in millions) of registered motor vehicles, if y represents the number of years after 2004?

- (A) $13.5 \times (1.023)^y$
- (B) $13.5 \times (0.023)^y$
- (C) $13.5 \times (1.023) \times y$
- (D) $13.5 \times (0.023) \times y$

- 15 Two people are to be selected from a group of six people to form a team.

How many different teams can be formed?

- (A) 15
- (B) 18
- (C) 30
- (D) 36

- 16 Two families borrow different amounts of money on the same day.

The Wang family has a flat rate loan. The Salama family has a reducing balance loan and repays the loan earlier than the Wang family.

Which graph best represents this situation?

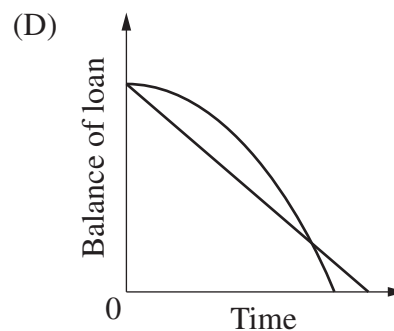
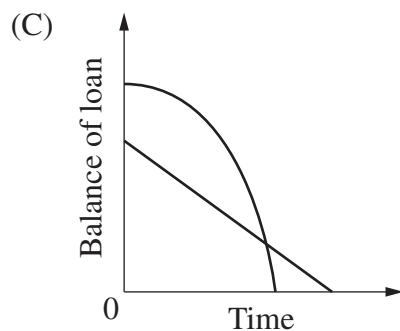
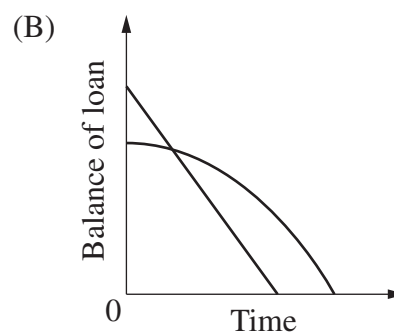
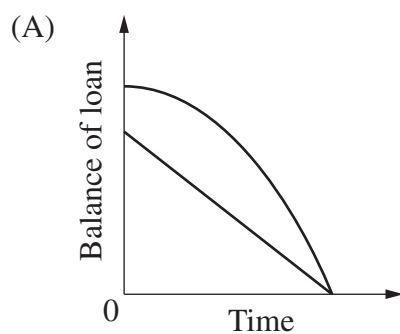

- 17 In a normally distributed set of scores, the mean is 23 and the standard deviation is 5.

Approximately what percentage of the scores will lie between 18 and 33?

- (A) 34%
- (B) 47.5%
- (C) 68%
- (D) 81.5%

- 18 What is the formula for q as the subject of $4p = 5t + 2q^2$?

- (A) $q = \pm \frac{\sqrt{5t - 4p}}{2}$
- (B) $q = \pm \frac{\sqrt{4p - 5t}}{2}$
- (C) $q = \pm \sqrt{\frac{5t - 4p}{2}}$
- (D) $q = \pm \sqrt{\frac{4p - 5t}{2}}$

- 19 Makoua and Macapá are two towns on the equator.

The longitude of Makoua is 16°E and the longitude of Macapá is 52°W .

How far apart are these two towns if the radius of Earth is approximately 6400 km?

- (A) 4000 km
- (B) 7600 km
- (C) 1 447 600 km
- (D) 2 734 400 km

20 The radius of a sphere is increased by 10%.

What is the percentage increase in its surface area?

- (A) 10%
- (B) 20%
- (C) 21%
- (D) 33%

21 Bill borrows \$420 000 to buy a house. Interest is charged at 7.2% per annum, compounded monthly.

How much does he owe at the end of the first month, after he has made a \$4000 repayment?

- (A) \$418 496
- (B) \$418 520
- (C) \$445 952
- (D) \$446 240

22 This income tax table is used to calculate Evelyn's tax payable.

<i>Taxable income</i>	<i>Tax payable</i>
\$0 – \$20 000	Nil
\$20 001 – \$45 000	Nil plus 10 cents for each \$1 over \$20 000
\$45 001 – \$70 000	\$2500 plus 35 cents for each \$1 over \$45 000
\$70 001 and above	\$11 250 plus 52 cents for each \$1 over \$70 000

Evelyn's taxable income increases from \$50 000 to \$80 000.

What percentage of her increase will she pay in additional tax?

- (A) 15.25%
- (B) 40.7%
- (C) 43.5%
- (D) 52%

Section II

78 marks

Attempt Questions 23–28

Allow about 2 hours for this section

Answer each question in a SEPARATE writing booklet. Extra writing booklets are available.

All necessary working should be shown in every question.

Marks

Question 23 (13 marks) Use a SEPARATE writing booklet.

(a) Simplify $\frac{ab^2}{w} \times \frac{4w}{3b}$.

2

- (b) This radar chart was used to display the average daily temperatures each month for two different towns.

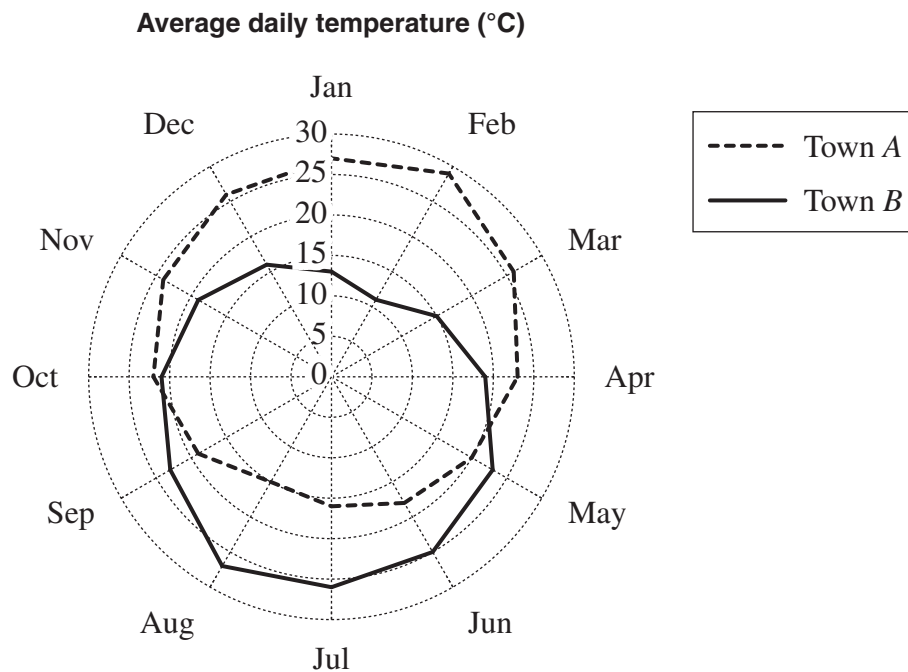

- (i) What is the average daily temperature of Town B for April? 1
- (ii) In which month do the average daily temperatures of the two towns have the greatest difference? 1
- (iii) In which months is the average daily temperature in Town B higher than in Town A? 1

Question 23 continues on page 12

Question 23 (continued)

- (c) Vicki wants to investigate the number of hours spent on homework by students at her high school.
- (i) Briefly describe a valid method of randomly selecting 200 students for a sample. **1**
- (ii) Vicki chooses her sample and asks each student how many hours (to the nearest hour) they usually spend on homework during one week. The responses are shown in the frequency table. **2**

<i>Number of hours spent on homework in a week</i>	<i>Frequency</i>
0 to 4	69
5 to 9	72
10 to 14	38
15 to 19	21

What is the mean amount of time spent on homework?

Question 23 continues on page 13

Question 23 (continued)

- (d) The graph shows the amounts charged by Company A and Company B to deliver parcels of various weights.

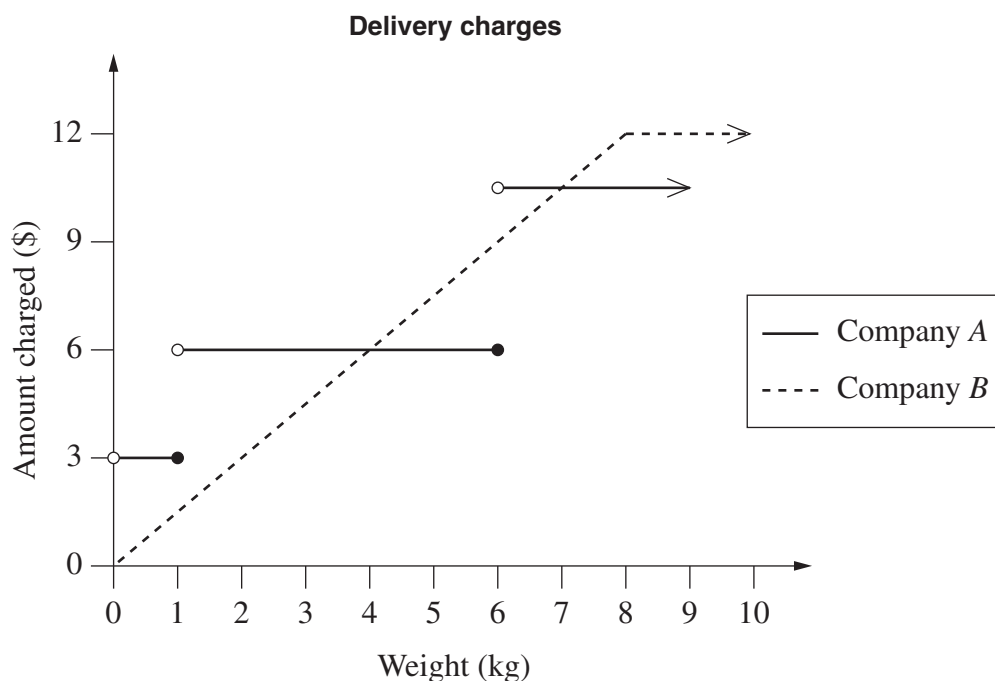

- (i) How much does Company A charge to deliver a 3 kg parcel? **1**
- (ii) Give an example of the weight of a parcel for which both Company A and Company B charge the same amount. **1**
- (iii) For what weight(s) is it cheaper to use Company A? **2**
- (iv) What is the rate per kilogram charged by Company B for parcels up to 8 kg? **1**

End of Question 23

Question 24 (13 marks) Use a SEPARATE writing booklet.

(a)

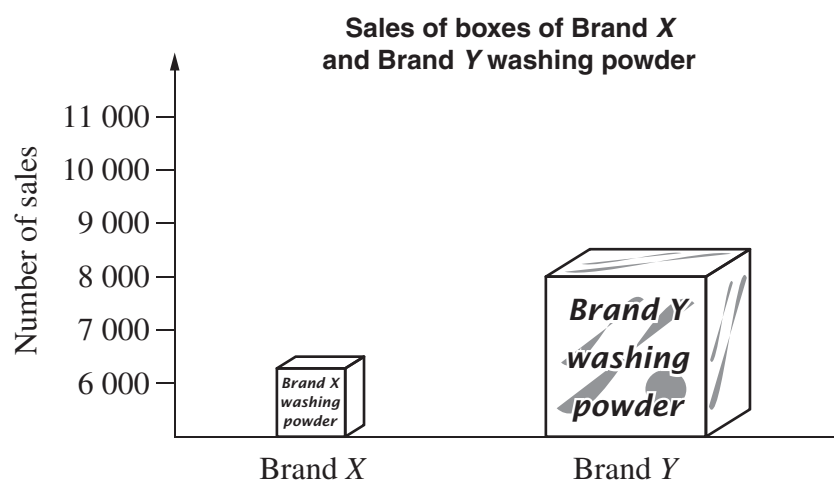

2

List TWO ways in which this graph is misleading.

(b) A 130 cm long garden rake leans against a fence. The end of the rake is 44 cm from the base of the fence.

(i) If the fence is vertical, find the value of θ to the nearest degree.

2

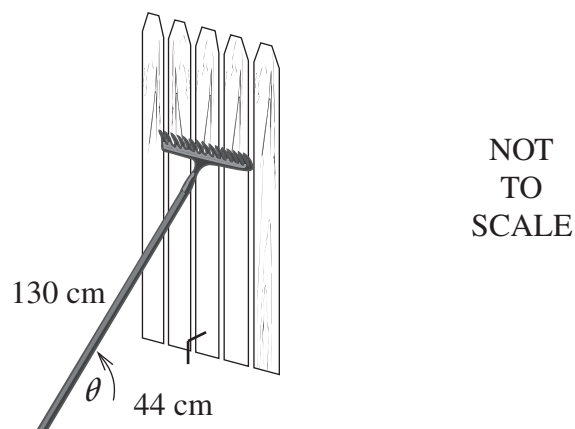

Question 24 continues on page 15

Question 24 (continued)

- (ii) The fence develops a lean and the rake is now at an angle of 53° to the ground. Calculate the new distance (x cm) from the base of the fence to the head of the rake. Give your answer to the nearest centimetre. 2

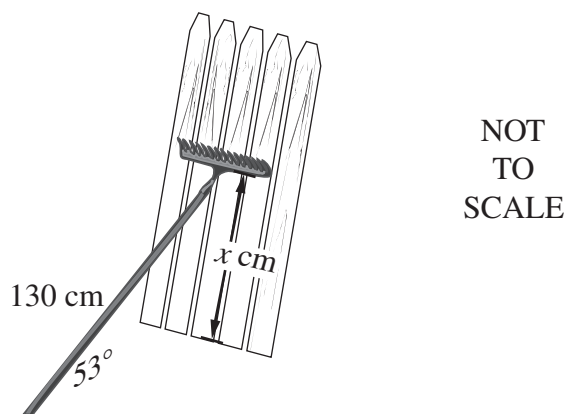

- (c) The heights of the 60 members of a choir were recorded. These results were grouped and then displayed as a cumulative frequency histogram and polygon. 3

The shortest person in the choir is 140 cm and the tallest is 190 cm.

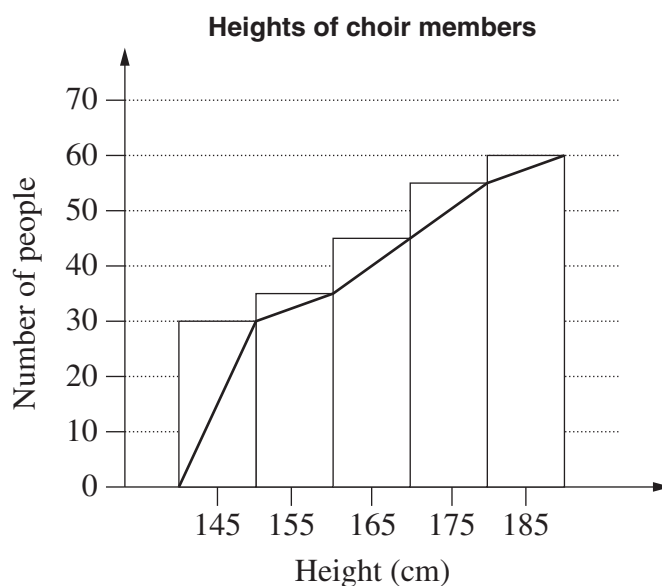

Draw an accurate box-and-whisker plot to represent the data.

Question 24 continues on page 16

Question 24 (continued)

- (d) A water trough has a uniform cross-section in the shape of half an ellipse. The width of the trough is 80 cm and the area of the shaded cross-section is 1890 cm^2 .

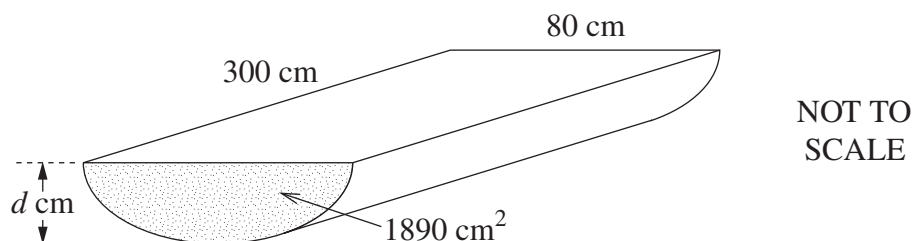

- (i) The trough is 300 cm long. Calculate the number of litres of water the trough will hold when it is full. 2
- (ii) Calculate the depth of the trough ($d \text{ cm}$). Give your answer to the nearest centimetre. 2

End of Question 24

Question 25 (13 marks) Use a SEPARATE writing booklet.

- (a) Three cards labelled C , J and M can be arranged in any order.

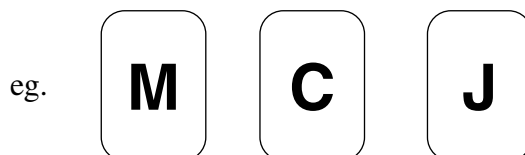

- (i) In how many different ways can the cards be arranged? 1
- (ii) What is the probability that the second card in an arrangement is a J ? 1
- (iii) What is the probability that the last card in an arrangement is not a C ? 1
- (b) In June, Ms Bigspender received a statement for her credit card account.

The account has no interest-free period. Simple interest is calculated and charged to her account on the statement date.

Ms Ima Bigspender		Sum Bank 	
Credit limit: \$2000		Credit Card Statement	
Statement date: 20 June 2006			
Previous balance	Payments	Purchases	Interest charged
\$263.83	\$263.83	\$617.72	<input style="width: 50px; height: 20px;" type="text"/>
<i>Date</i>	<i>Purchases</i>	<i>Amount</i>	
23 May	Concert tickets	\$617.72	
Annual percentage rate: 18.2%			
Daily percentage rate: 0.0498%			
<i>Note: Interest is charged on amounts from (and including) the date of purchase up to (and including) the statement date.</i>			

- (i) For how many days is she charged interest on her purchase? 1
- (ii) Calculate the interest charged to her account. 2

Question 25 continues on page 18

Question 25 (continued)

- (c) Sonia buys three raffle tickets.

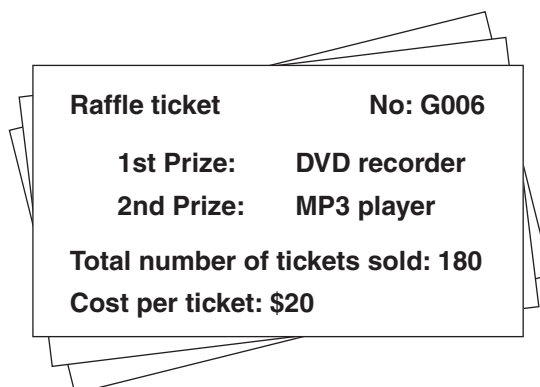

- (i) What is the probability that Sonia wins first prize? **1**
- (ii) What is the probability that she wins both prizes? **2**
- (d) Paul invested money in a bank for 4 years. The stated interest rate on the account was 6.1% per annum *compounded annually*. This is equivalent to an effective simple interest rate of 6.68% per annum. **4**

The formula Paul used to calculate the effective simple interest rate was:

$$E = \frac{(1+r)^n - 1}{n} \quad \text{where } r \text{ is the stated interest rate per period (expressed as a decimal)}$$

E is the effective simple interest rate per period (expressed as a decimal)

n is the number of periods

Martha invested money in a different bank for 4 years. The stated interest rate on her investment was 6% per annum *compounded monthly*.

Martha thinks that she has a better deal than Paul. Do you agree? Justify your answer by comparing their effective simple interest rates.

End of Question 25

Question 26 (13 marks) Use a SEPARATE writing booklet.

- (a) Daniel conducts an offset survey to sketch a diagram, $ABCD$, of a block of land.

Daniel walks from A to C , a distance of 62 m.

When he is 15 m from A , he notes that point D is 25 m to his right.

When he is 57 m from A , he notes that point B is 20 m to his left.

This is his notebook entry.

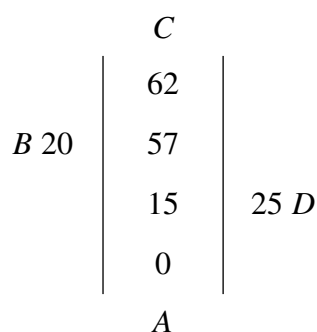

- (i) Draw a neat sketch of the block of land. Label A , B , C and D on your diagram. 1
- (ii) Calculate the distance from C to D . (Give your answer to the nearest metre.) 2
- (b) The roof of this greenhouse is a square pyramid with identical triangular faces. The sides of the greenhouse are rectangles and there is no floor. The dimensions of the greenhouse are shown on the diagram.

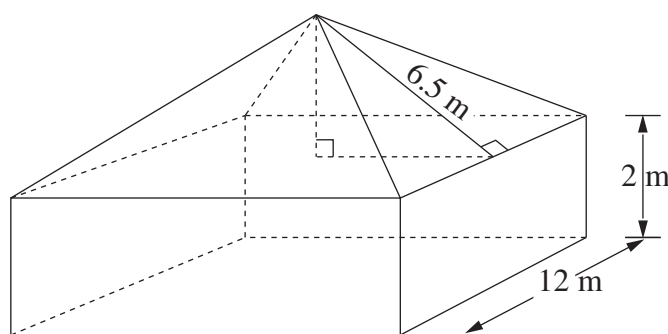

- (i) Sketch a possible net of the greenhouse. 1
- (ii) Calculate the surface area of the greenhouse. 2

Question 26 continues on page 20

Question 26 (continued)

- (c) A new test has been developed for determining whether or not people are carriers of the Gaussian virus.

Two hundred people are tested. A two-way table is being used to record the results.

	<i>Positive</i>	<i>Negative</i>
<i>Carrier</i>	74	12
<i>Not a carrier</i>	16	A

- (i) What is the value of *A*? **1**
- (ii) A person selected from the tested group is a carrier of the virus. **2**
 What is the probability that the test results would show this?
- (iii) For how many of the people tested were their test results inaccurate? **1**
- (d) Cassie flew from London (52°N, 0°E) to Manila (15°N, 120°E). **3**

Her plane left London at 9.30 am Monday (London time), stopped for 5 hours in Singapore and arrived in Manila at 4.00 pm Tuesday (Manila time).

What was the total flying time? (Ignore time zones.)

End of Question 26

Question 27 (13 marks) Use a SEPARATE writing booklet.

- (a) Liliana wants to borrow money to buy a house. The bank sent her an email with the following table attached.

Monthly repayments

<i>Amount borrowed</i>	<i>Term of loan</i>				
	10 years	15 years	20 years	25 years	30 years
	120 months	180 months	240 months	300 months	360 months
\$80 000	\$970.62	\$764.52	\$669.15	\$617.45	\$587.01
\$90 000	\$1091.95	\$860.09	\$752.80	\$694.63	\$660.39
\$100 000	\$1213.28	\$955.65	\$836.44	\$771.82	\$733.76
\$110 000	\$1334.60	\$1051.22	\$920.08	\$849.00	\$807.14
\$120 000	\$1455.93	\$1146.78	\$1003.73	\$926.18	\$880.52
\$130 000	\$1577.26	\$1242.35	\$1087.37	\$1003.36	\$953.89
\$140 000	\$1698.59	\$1337.91	\$1171.02	\$1080.54	\$1027.27
\$150 000	\$1819.91	\$1433.48	\$1254.66	\$1157.72	\$1100.65
\$160 000	\$1941.24	\$1529.04	\$1338.30	\$1234.91	\$1174.02

- (i) Liliana decides that she can afford \$1000 per month on repayments. **1**
 What is the maximum amount she can borrow, and how many years will she have to repay the loan?
- (ii) Zali intends to borrow \$160 000 over 15 years from the same bank. **2**
 If she chooses to borrow \$160 000 over 20 years instead, how much more interest will she pay?

Question 27 continues on page 22

Question 27 (continued)

- (b) Each member of a group of males had his height and foot length measured and recorded. The results were graphed and a line of fit drawn.

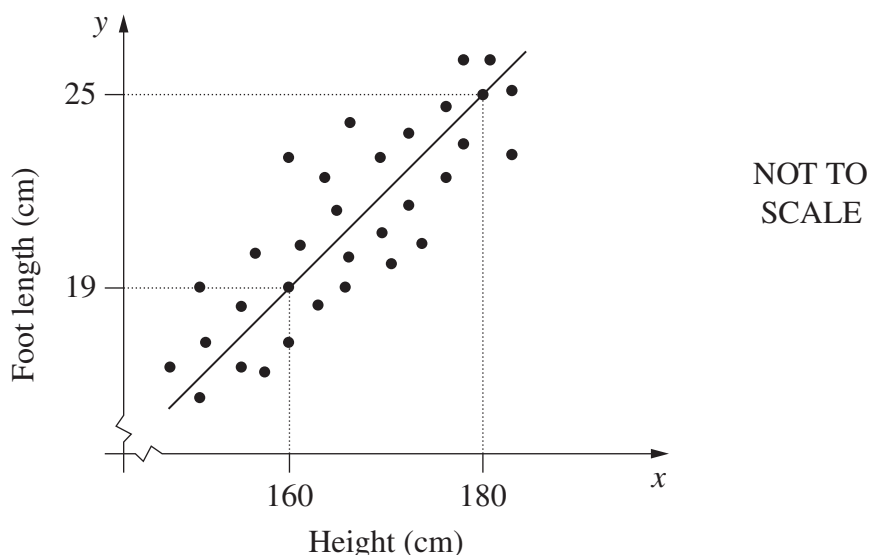

- (i) Why does the value of the y -intercept have no meaning in this situation? 1
- (ii) George is 10 cm taller than his brother Harry. Use the line of fit to estimate the difference in their foot lengths. 1
- (iii) Sam calculated a correlation coefficient of -1.2 for the data. Give TWO reasons why Sam must be incorrect. 2
- (c) Kai purchased a new car for \$30 000. It depreciated in value by \$2000 per year for the first three years.

After the end of the third year, Kai changed the method of depreciation to the declining balance method at the rate of 25% per annum.

- (i) Calculate the value of the car at the end of the third year. 1
- (ii) Calculate the value of the car seven years after it was purchased. 2
- (iii) Without further calculations, sketch a graph to show the value of the car over the seven years. 3

Use the horizontal axis to represent time and the vertical axis to represent the value of the car.

End of Question 27

Question 28 (13 marks) Use a SEPARATE writing booklet.

- (a) On a bridge, the toll of \$2.50 is paid in coins collected by a machine. The machine only accepts two-dollar coins, one-dollar coins and fifty-cent coins.
- (i) List the different combinations of coins that could be used to pay the \$2.50 toll. **1**
 - (ii) Jill has three two-dollar coins, six one-dollar coins and two fifty-cent coins. She selects two coins at random. What is the probability that she selects exactly \$2.50? **3**
 - (iii) At the end of a day, the machine contains x two-dollar coins, y one-dollar coins and w fifty-cent coins. Write an expression for the total value of coins in dollars in the machine. **1**
- (b) A new tunnel is built. When there is no toll to use the tunnel, 6000 vehicles use it each day. For each dollar increase in the toll, 500 fewer vehicles use the tunnel.
- (i) Find the lowest toll for which no vehicles will use the tunnel. **1**
 - (ii) For a toll of \$5.00, how many vehicles use the tunnel each day and what is the total daily income from tolls? **2**
 - (iii) If d (dollars) represents the value of the toll, find an equation for the number of vehicles (v) using the tunnel each day in terms of d . **2**
 - (iv) Anne says ‘A higher toll always means a higher total daily income’. **3**
Show that Anne is incorrect and find the maximum daily income from tolls. (Use a table of values, or a graph, or suitable calculations.)

End of paper

BLANK PAGE

FORMULAE SHEET

Area of an annulus

$$A = \pi(R^2 - r^2)$$

R = radius of outer circle

r = radius of inner circle

Area of an ellipse

$$A = \pi ab$$

a = length of semi-major axis

b = length of semi-minor axis

Area of a sector

$$A = \frac{\theta}{360} \pi r^2$$

θ = number of degrees in central angle

Arc length of a circle

$$l = \frac{\theta}{360} 2\pi r$$

θ = number of degrees in central angle

Simpson's rule for area approximation

$$A \approx \frac{h}{3} (d_f + 4d_m + d_l)$$

h = distance between successive measurements

d_f = first measurement

d_m = middle measurement

d_l = last measurement

Surface area

Sphere $A = 4\pi r^2$

Closed cylinder $A = 2\pi rh + 2\pi r^2$

r = radius

h = perpendicular height

Volume

Cone $V = \frac{1}{3} \pi r^2 h$

Cylinder $V = \pi r^2 h$

Pyramid $V = \frac{1}{3} Ah$

Sphere $V = \frac{4}{3} \pi r^3$

r = radius

h = perpendicular height

A = area of base

Sine rule

$$\frac{a}{\sin A} = \frac{b}{\sin B} = \frac{c}{\sin C}$$

Area of a triangle

$$A = \frac{1}{2} ab \sin C$$

Cosine rule

$$c^2 = a^2 + b^2 - 2ab \cos C$$

or

$$\cos C = \frac{a^2 + b^2 - c^2}{2ab}$$

FORMULAE SHEET

Simple interest

$$I = Prn$$

P = initial quantity

r = percentage interest rate per period,
expressed as a decimal

n = number of periods

Compound interest

$$A = P(1+r)^n$$

A = final balance

P = initial quantity

n = number of compounding periods

r = percentage interest rate per compounding
period, expressed as a decimal

Future value (A) of an annuity

$$A = M \left\{ \frac{(1+r)^n - 1}{r} \right\}$$

M = contribution per period,
paid at the end of the period

Present value (N) of an annuity

$$N = M \left\{ \frac{(1+r)^n - 1}{r(1+r)^n} \right\}$$

or

$$N = \frac{A}{(1+r)^n}$$

Straight-line formula for depreciation

$$S = V_0 - Dn$$

S = salvage value of asset after n periods

V_0 = purchase price of the asset

D = amount of depreciation apportioned
per period

n = number of periods

Declining balance formula for depreciation

$$S = V_0(1-r)^n$$

S = salvage value of asset after n periods

r = percentage interest rate per period,
expressed as a decimal

Mean of a sample

$$\bar{x} = \frac{\sum x}{n}$$

$$\bar{x} = \frac{\sum fx}{\sum f}$$

\bar{x} = mean

x = individual score

n = number of scores

f = frequency

Formula for a z-score

$$z = \frac{x - \bar{x}}{s}$$

s = standard deviation

Gradient of a straight line

$$m = \frac{\text{vertical change in position}}{\text{horizontal change in position}}$$

Gradient-intercept form of a straight line

$$y = mx + b$$

m = gradient

b = y-intercept

Probability of an event

The probability of an event where outcomes
are equally likely is given by:

$$P(\text{event}) = \frac{\text{number of favourable outcomes}}{\text{total number of outcomes}}$$