

B O A R D O F S T U D I E S
NEW SOUTH WALES

2010

**HIGHER SCHOOL CERTIFICATE
EXAMINATION**

Information Processes and Technology

General Instructions

- Reading time – 5 minutes
- Working time – 3 hours
- Write using black or blue pen
- Draw diagrams using pencil

Total marks – 100

Section I Pages 2–9

20 marks

- Attempt Questions 1–20
- Allow about 40 minutes for this section

Section II Pages 10–14

40 marks

- Attempt Questions 21–24
- Allow about 1 hour and 10 minutes for this section

Section III Pages 15–20

40 marks

- Attempt TWO questions from Questions 25–28
- Allow about 1 hour and 10 minutes for this section

Section I

20 marks

Attempt Questions 1–20

Allow about 40 minutes for this section

Use the multiple-choice answer sheet for Questions 1–20.

- 1** A library maintains a card-based system, indexed by title, to help borrowers find books. There is only one card for each book containing data on the title, the publisher, the author, the topics, the date of publication and a location number.

Using the card-based system, which of the following would enable the user to determine the location of a book?

- (A) The author's name but not the title
 - (B) The title but not the date of publication
 - (C) The book's publisher but not the author
 - (D) The topics that a book covers but not the title
- 2** A student uses a digital photograph of another student in an email.
- Which issue needs to be considered in this scenario?
- (A) Privacy
 - (B) Security
 - (C) Copyright
 - (D) Accuracy of information
- 3** Which of the following refers to a subscription-based web-feed that provides users with frequently updated content?
- (A) OLAP
 - (B) RSS
 - (C) SSL
 - (D) VOIP

- 4 A DVD store maintains a customer database. Each new customer is asked to complete a form by providing his or her contact details, including address, phone numbers and email contact. Each time a customer borrows a DVD the customer is asked to confirm his or her address details only, and updates are made as needed.

Which statement about the quality of this data is true?

- (A) The data quality is good because the data stored is always up to date.
 - (B) The data quality is good because the data stored is constantly revised.
 - (C) The data quality is poor because much of the data could be out of date and there is no way of checking.
 - (D) The data quality is poor because there are no verification procedures in place to ensure it is accurate.
- 5 A large clothing-store chain has recently made major upgrades to its stock/sales information system. Many of the staff need to be trained in the use of the new information system. The director is implementing the new system in the following sequence:
- men's clothing section
 - women's clothing section
 - children's clothing section.

Which of the following methods of conversion is being used?

- (A) Direct
 - (B) Parallel
 - (C) Phased
 - (D) Pilot
- 6 The owner/operator of a retail store is designing a database to manage stock/sales within the workplace. Initially she designs the solution on a spreadsheet prior to developing the information system using a Database Management System.

Which development approach would be most appropriate?

- (A) Outsource
- (B) Prototyping
- (C) Structured
- (D) Traditional

- 7 Which of the following statements about normalisation is true?
- (A) A query would not require normalising.
 - (B) A flat file would not require normalising.
 - (C) Normalisation reduces data redundancy.
 - (D) Normalisation eliminates data duplication.
- 8 What is a term for the screens and reports produced from stored database data?
- (A) Views
 - (B) Vistas
 - (C) Visions
 - (D) Vertices

Use the following information to answer Questions 9–10.

A school assistant maintains a flat-file database to manage vehicle owners who use the school's carpark on a daily basis. The data dictionary contains the following metadata.

Field name	Field length in bytes
Driver_Surname	44
Driver_FirstNames	40
Driver_DOB	6
Car_Make	12
Car_Manufacture_Year	4
Car_Registration	8
Licence_No	6

- 9 Approximately how much storage space would 1000 records require?
- (A) 120 bytes
 - (B) 120 kilobytes
 - (C) 120 megabytes
 - (D) 120 gigabytes

- 10 The database designer has decided that the flat-file database should be redesigned and split into two tables, a **Driver** table and a **Car** table.

Which of the following options provides the best schema for the two new tables?
(P = primary key, F = foreign key)

(A)

Driver	Car
Driver_Surname (P)	Licence_No (P)
Driver_FirstNames	Car_Make
Driver_DOB	Car_Manufacture_Year
Licence_No (F)	Car_Registration

(B)

Driver	Car
Driver_Surname	Car_Make
Driver_FirstNames	Car_Manufacture_Year
Driver_DOB	Car_Registration (P)
Licence_No (P)	Licence_No (F)

(C)

Driver	Car
Driver_Surname (P)	Car_Registration (P)
Driver_FirstNames	Car_Make
Driver_DOB	Car_Manufacture_Year
Car_Registration (F)	Driver_Surname (F)

(D)

Driver	Car
Driver_Surname (P)	Car_Registration (F)
Driver_FirstNames	Car_Make
Driver_DOB	Car_Manufacture_Year
Car_Registration	Licence_No

- 11 Which of the following provides the best example of a virtual community?

- (A) Shoppers purchasing goods online
- (B) Doctors meeting at a conference in a regional town
- (C) Friends emailing each other from different parts of the world
- (D) Students participating online in an international environmental forum

Use the following information to answer Questions 12–13.

The Gantt chart outlines the times taken to complete tasks when introducing a new system.

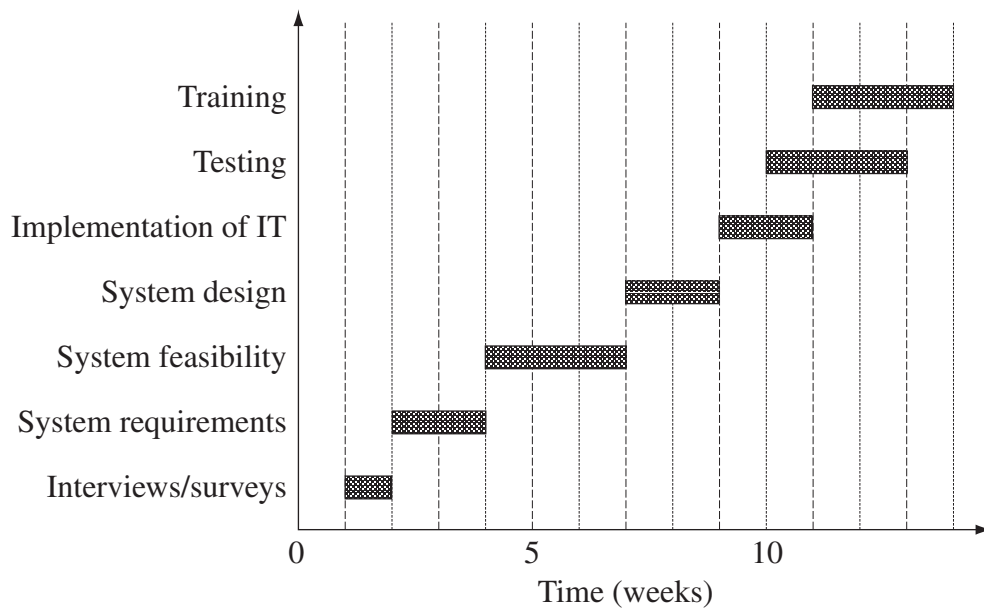

12 Which tasks were completed over a period of five weeks?

- (A) System feasibility, testing, training
- (B) Implementation of IT, testing, training
- (C) Interviews/surveys, system requirements, system feasibility
- (D) System requirements, system design, implementation of IT

13 The project team had planned to implement the new hardware and software in the week it was received. The supplier has just informed the project team that the delivery date is now the beginning of week 10.

How many weeks will the original plan be delayed by?

- (A) 1
- (B) 2
- (C) 3
- (D) 4

- 14** An e-commerce site offers perfumes for sale online. Since launching the site, the website functionality, ease of navigation and payment system have been tested. Sales have grown from two to fifty purchases per hour. This increased sales growth has caused the system to malfunction.

Which of the following test data should have been used in the testing stage of development?

- (A) Live
 - (B) Real
 - (C) Unit
 - (D) Volume
- 15** What is 'smtp'?
- (A) A communications protocol used for receiving files sent from one computer to another over a network
 - (B) An internet standard for sending email messages from one computer to a server over a network
 - (C) An internet standard for securing email messages from one computer to a server over a network
 - (D) A protocol used for sending secure webpages and webpage components over the internet
- 16** Jim has hired a project team to build a new information system for his business. The project manager has provided a feasibility report.

Using a traditional system of development approach, which of the following does Jim need to consider next?

- (A) How installation of hardware and software will occur
- (B) How the specifications for the design will be developed
- (C) How the staff will be trained and the system will be tested
- (D) How the new system will help the business achieve its purpose

17 What name is given to a network of many interlinked LANs within an organisation used to securely share information and software?

- (A) Extranet
- (B) Internet
- (C) Intranet
- (D) Wireless

18 1. Shopping cart

xxxxxx xx xx
 xxxxxxxxxxxx xxx xxx

xxx

xxxxxxx xxx

Back Next

2. Login

xxxxxxxxx

xxxxxxxxxxxx

Email

Password xxx

xxxxxxxxxxxx

Email

Password

xxxx

Back xxx Next

3. Address

xxxxxxxxx xxxxxx x

Xxxx

Xxxx

Xxxx

Xxxx

Xxxx

Xxxx

Back Submit

4. Payment information

Payment information

Name

Card number

Expiry date / CVC

Xxxxx

Back Submit

5. Thank you

Thank you for purchasing our product.

Continue shopping

Which of the following sets contains three elements that are displayed in the sequence of screens shown above?

- (A) Menus, radio buttons, scroll bars
- (B) Menus, check-boxes, radio buttons
- (C) Data entry, input mask, scroll bars
- (D) Text boxes, radio buttons, drop-down menus

- 19** An information system is used by a retail hardware store to record the sales completed at one of its branches.

Which of the following best describes the purpose of such an information system?

- (A) To process the transaction data
 - (B) To reduce the transaction details
 - (C) To describe the transaction schema
 - (D) To data mine the transaction records
- 20** In which list are all the elements characteristics of Network Operating Systems?
- (A) File searches, secure logins for users, accept multiple users, multitasking
 - (B) Text searching, process transactions, allocate network addresses, accept multiple users
 - (C) Scheduling of tasks, controlled access to network resources, accept multiple users, audio processing
 - (D) Allocate network addresses, secure logins for users, controlled access to network resources, scheduling of tasks

Section II

40 marks

Attempt Questions 21–24

Allow about 1 hour and 10 minutes for this section

Answer each question in the appropriate writing booklet. Extra writing booklets are available.
If you include diagrams in your answer, ensure that they are clearly labelled.

Question 21 (9 marks) Use the Question 21 writing booklet.

A state government is introducing new digital combined red light/speed cameras. These new cameras are very similar to existing speed and red light cameras, except that they use digital imaging technology and utilise different detection technologies such as road sensors as opposed to radar devices.

The digital camera works by taking a digital image of any vehicle that runs a red light and/or exceeds the speed limit. The image and information is then loaded directly into the infringement processing system.

- (a) Draw a context diagram to represent the new system. **2**

- (b) What information technology is required by the new system? **2**

- (c) The first digital camera will be installed in one location and if it proves to be successful, the new system will be rolled out across the state. **3**

Justify this method of converting from the existing system to the new system.

- (d) Describe a social and/or ethical issue related to the digital red light/speed camera. **2**

In your answer consider the position of either the owner/driver or the state government.

Question 22 (10 marks) Use the Question 22 writing booklet.

- (a) Describe a difference between a thin client and a fat client. 2
- (b) A local high school has introduced an internet-based online payment system for school fees.

Parents can make online payments to pay the fees and receive an electronic receipt which includes the date of payment, fees paid and the student's name and ID.

The school administrator is able to produce reports from the system to list those students whose parents have paid fees, and when those payments were made. Lists can also be produced to show those students whose parents have not paid fees to date.

The following diagram describes the communication system.

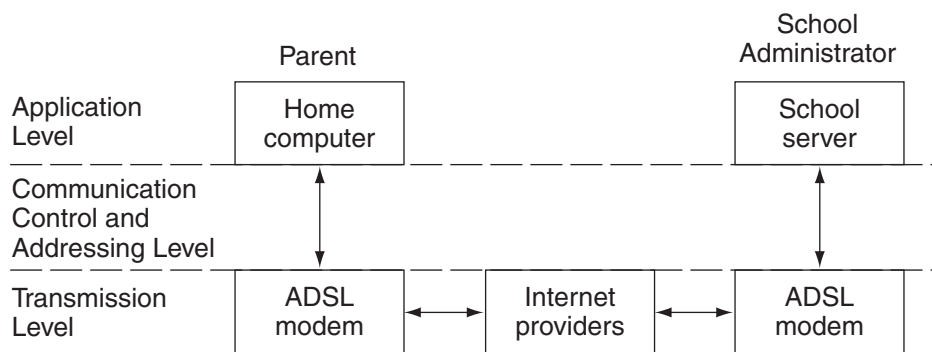

- (i) Prepare a data dictionary for the school payment system including: 2
- field name
 - data type
 - appropriate size for the data.
- (ii) Explain how the message sent by the home computer is organised into packets of data, transmitted and reassembled at the school server. 3
- (iii) Explain a suitable error detection technique to ensure that messages are sent and received accurately. 3

Question 23 (10 marks) Use the Question 23 writing booklet.

The Carbon Footprint Calculator is an online calculator that can estimate the size of your carbon footprint. When you enter details about home, travel and lifestyle habits the calculator produces a graph displaying the impact of your current emissions against the average Australian household emissions and identifies ways for you to cut emissions.

The calculator is displayed below.



Carbon Footprint Calculator

1. What state do you live in?

2. What sort of home do you live in?
 House Unit

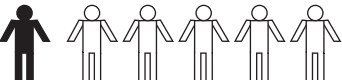
3. How many people? (click to select)



4. How much electricity do you use?
My electricity consumption is
 kWh

5. How much natural gas do you use?
My natural gas consumption is
 MJ

6. Which energy saving measures have you installed in your home?
 Roof insulation Double glazing
 Energy efficient lighting
 Energy efficient appliances

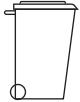
7. How much garbage do you put out for collection? (click to select)

Wheelie bin

Smaller bin

Household bin

8. Which energy saving habits have you adopted?

I hang my clothes on the line rather than using the tumble dryer.

I have drapes or blinds on larger windows to reduce heat transfer.

I switch off lights when I leave the room.

I switch off electrical equipment at the wall when not in use.

9. What type of public transport does your household use?

Mode

Kms travelled

Time period

10. Which travel-smart behaviours has your household adopted?

Car sharing

Cycling or walking to school/work

Question 23 continues on page 13

Question 23 (continued)

- (a) Identify a technique that has been implemented to reduce data entry errors and explain why it is appropriate. **2**
- (b) Explain why the developers of the Carbon Footprint Calculator have used the screen elements in Questions 3 and 7 rather than other data collection methods. **2**
- (c) On completion of the data entry, the Carbon Footprint Calculator provides the user with a graph of the results, titled 'My Footprint'. The results (calculated in tonnes of CO₂) include: **3**
- Household total
 - Transport total
 - Australian 'My Footprint' average.

Design a screen to display the results of the Carbon Footprint Calculator.

- (d) Describe the analysing processes needed by the Carbon Footprint Calculator in order to generate information. **3**

End of Question 23

Question 24 (11 marks) Use the Question 24 writing booklet.

A hardware developer has been given the following specifications for a new device called the Digibook for displaying digital books and magazines. The device needs to be lightweight, with a wireless link to download digital books from the internet.

Digibook should allow storage of up to 2000 books and will display a single page on a 15 cm display panel. The Digibook will also have a built in keyboard and additional page navigation buttons.

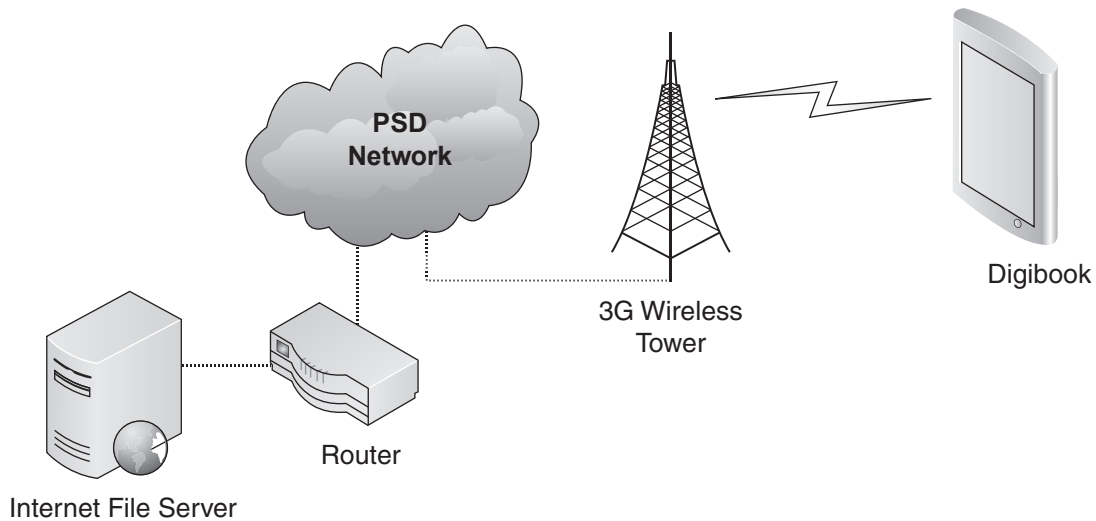

- (a) Digibook users will be able to purchase books online and download them for a fraction of the cost of purchasing paper-based books. **3**

Describe ONE social and ONE ethical issue that may arise from the downloading of digital books.

- (b) Discuss issues of feasibility related to the success of the Digibook. **3**

- (c) The Digibook's WiFi 3G network link allows users to connect to the internet. Using an inbuilt web browser, users can purchase digital books from a variety of online stores. **5**

Explain the communication protocols in use during the transmission of a digital book from the supplier's internet fileserver to the user's Digibook.

Section III

40 marks

Attempt TWO questions from Questions 25–28

Allow about 1 hour and 10 minutes for this section

Answer each question in a SEPARATE writing booklet. Extra writing booklets are available.

If you include diagrams in your answer, ensure that they are clearly labelled.

Question 25 — Transaction Processing Systems (20 marks)

Use a SEPARATE writing booklet.

- | | | | |
|-----|------|--|----------|
| (a) | (i) | What is a Radio Frequency Identification (RFID) tag ? | 1 |
| | (ii) | Describe the use of transaction logs in a transaction processing system. | 2 |
| (b) | (i) | Identify characteristics of a transaction processing system where real-time processing is appropriate. | 2 |
| | (ii) | Explain why batch processing could be the best solution when processing transactions. | 3 |

Question 25 continues on page 16

Question 25 (continued)

- (c) A parking system coordinates the entry and exit of vehicles into a private car park.

Account holders are given automated access to the carpark using licence plate recognition and can have any number of vehicles registered to their account.

The system operates by taking a photo of vehicles on entry to the carpark and compares the plate number to those of account holders it holds on a database. If there is a match the vehicle is allowed to continue. The same procedure occurs on exit.

Times are kept in a transaction log for each entry and exit. An amount is then debited from the account holder's nominated bank account at the end of each month.

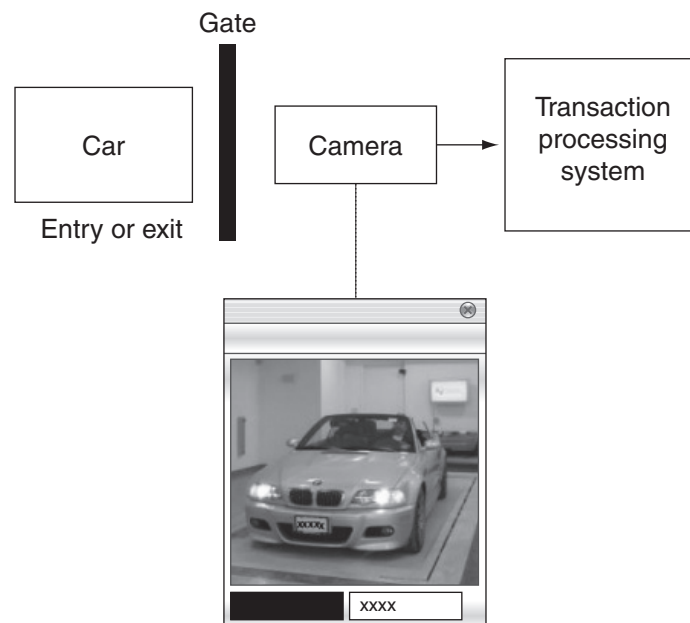

- (i) Construct a data flow diagram for the vehicle entry subsystem of the parking system showing all external entities, data flows, processes and data stores. **3**
- (ii) Describe the collecting and storing/retrieving information processes of this parking system. **4**
- (iii) Predict a future application of the technology used in this system. In your response, consider security and the changing nature of work. **5**

End of Question 25

Question 26 — Decision Support Systems (20 marks)

Use a SEPARATE writing booklet.

- (a) (i) Define the term *data warehouse*. **1**
- (ii) Describe the characteristics of a semistructured decision support system. **2**
- (b) (i) Identify a type of inference engine and give an example of where this type of inference engine would be useful. **2**
- (ii) Discuss how group decision support systems can be used to support decision making. **3**
- (c) A web access analysis tool is available to help website managers to improve their understanding of the accesses to their site. The tool analyses the data collected and generates reports. It operates in realtime every time a site is accessed.

In particular, reports are provided relating to:

- tracking of banner ads
- transactions arising from sales
- keywords used to search the site
- benchmarking, including how a site underperforms or outperforms compared to competitors' websites.

Operating by collecting and storing all possible data, the tool analyses the collected data to provide the above reports.

- (i) Explain how data from the tool's reports can be used to assist a website manager. **3**
- (ii) Describe the analysing and collecting information processes of the web analysis tool. **4**
- (iii) Predict a future application of this technology. In your response, consider responsibility for decisions and responsibility of those performing data mining. **5**

Question 27 — Automated Manufacturing Systems (20 marks)

Use a SEPARATE writing booklet.

- (a) (i) In the context of an automated manufacturing system, define a *direct user*. **1**
- (ii) Describe a scenario where Radio Frequency Identification (RFID) tags could be utilised. **2**
- (b) (i) Identify an actuator and a system for which it can be used. **2**
- (ii) Describe the processes undertaken by the automated manufacturing system identified in the following diagram. **3**

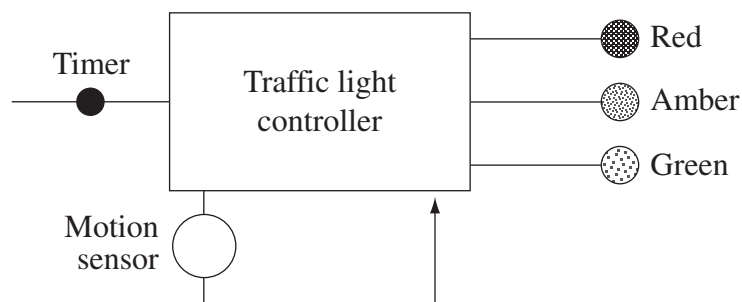

- (c) Robotic technology can now commonly be found in hospitals performing what was formerly human work in the laboratory and operating theatre.

Surgeons use joystick controls while sitting at a computer to control a robot that is operating on a patient. The robot has three arms, one carrying a pair of miniature cameras to produce a 3D image of inside the patient's body, which the surgeon views on a monitor. The surgeon controls the other two robotic arms to perform the operation.

- (i) Explain whether this system is human-centred or machine-centred. **3**
- (ii) Describe the collecting and displaying information processes of this robotic system. **4**
- (iii) Predict a future application of the technology used in this system. In your response, consider job flexibility and changing skills. **5**

Question 28 — Multimedia Systems (20 marks)

Use a SEPARATE writing booklet.

- (a) (i) In the context of multimedia systems, define *interactivity*. **1**
- (ii) Describe the difference between linear and non-linear storyboards. **2**
- (b) (i) Identify the characteristics of file formats that allow video content to be embedded into a web page. **2**
- (ii) Describe a situation where path-based and cell-based animation could be used. **3**
- (c) Interactive gaming systems incorporate the use of infrared and motion control technologies to simulate real-life movement. Recently numerous fitness games have been developed around a hardware device called a balance board. This device has inbuilt accelerometers which sense small shifts in a person's posture when standing on the board. This information is transferred through a wireless bluetooth link to the controller and processed so that the onscreen character mimics the user's movements exactly.

The sensors also provide data which allow the user to calculate their body mass index and measure their performance during an exercise activity.

In the skiing game, the user stands on the balance board to control their onscreen character as it skis downhill. The background scene is also animated, changing interactively depending on data coming from the board, providing the user with a virtual reality experience. The user's speed is calculated and displayed continuously on the screen. A progressive points score is also displayed depending on how the player negotiates sections of the course. Even the audio is interactive with the rushing sound changing as the player moves from side to side on the balance board.

Question 28 continues on page 20

Question 28 (continued)

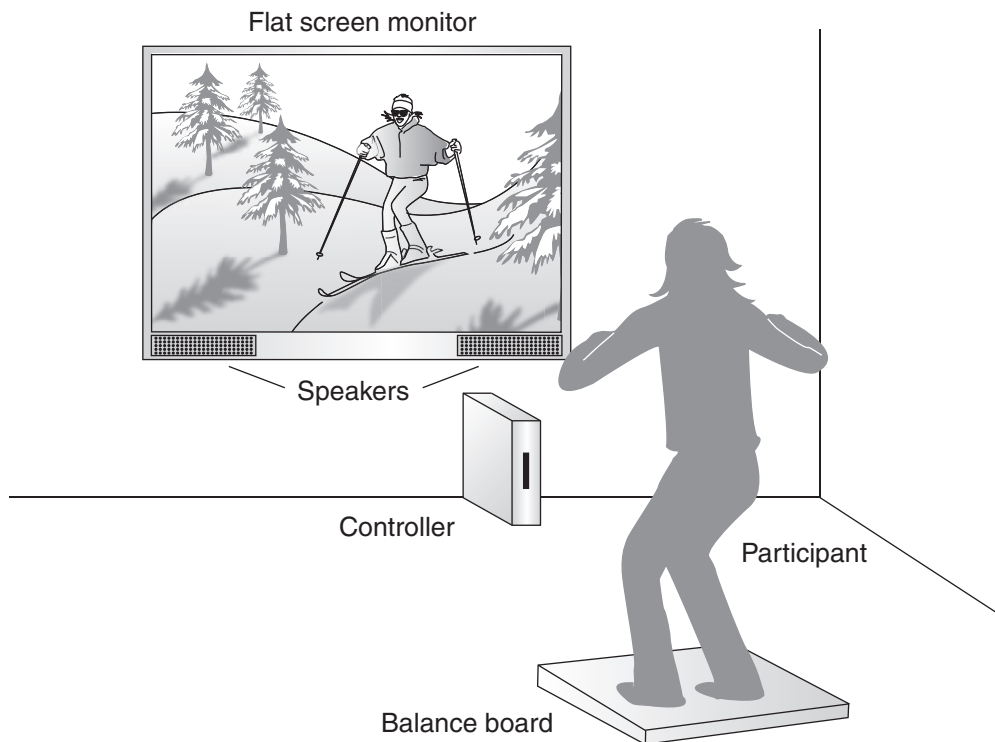

- (i) Explain the need for data compression on the files storing the multimedia content in this game. **3**
- (ii) Describe the collecting and displaying information processes of the interactive gaming system. **4**
- (iii) Predict a future use of the technology used in this system. In your response, consider use of future multimedia systems and virtual worlds. **5**

End of paper