

B O A R D O F S T U D I E S
NEW SOUTH WALES

2010

**HIGHER SCHOOL CERTIFICATE
EXAMINATION**

Industrial Technology

Electronics Technologies

General Instructions

- Reading time – 5 minutes
- Working time – $1\frac{1}{2}$ hours
- Write using black or blue pen
- Draw diagrams using pencil
- Board-approved calculators may be used
- Write your Centre Number and Student Number at the top of page 9

Total marks – 40

Section I Pages 2–5

10 marks

- Attempt Questions 1–10
- Allow about 20 minutes for this section

Section II Pages 9–13

15 marks

- Attempt Questions 11–16
- Allow about 35 minutes for this section

Section III Page 17

15 marks

- Attempt Question 17
- Allow about 35 minutes for this section

Section I

10 marks

Attempt Questions 1–10

Allow about 20 minutes for this section

Use the multiple-choice answer sheet for Questions 1–10.

- 1** Which of the following is the best conductor of electricity?

 - (A) Tin
 - (B) Copper
 - (C) Aluminium
 - (D) Low carbon steel

- 2** What does VLSI stand for in integrated circuits?

 - (A) Very low scale of integration
 - (B) Very large scale of integration
 - (C) Very low system of integration
 - (D) Very large system of integration

- 3** What electronic component is used for switching a large current?

 - (A) Light emitting diode
 - (B) Thermistor
 - (C) Thyristor
 - (D) Baristor transformer

- 4** Which of the following is a mechanical output device that consists of a coil and a plunger?

 - (A) A reed switch
 - (B) A control regulator
 - (C) A solenoid
 - (D) A relay

- 5 The graph shown represents the sine wave graph of an alternating current.

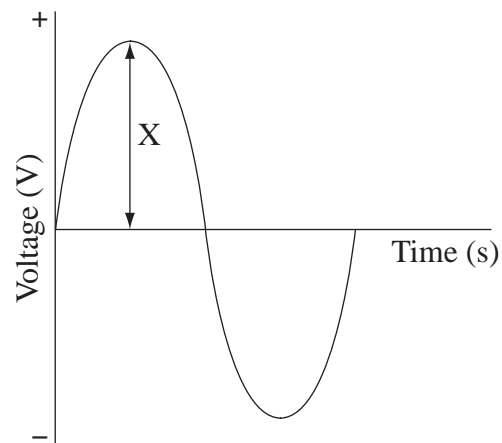

What does the distance X represent?

- (A) Amplitude
 - (B) Frequency
 - (C) Period
 - (D) Peak-to-peak value
- 6 A computer controlled machine is designed to undertake complicated and intricate tasks.

What is the best electric motor for this task?

- (A) Stepper
- (B) Alternator
- (C) Free running
- (D) Motor generator

- 7 A junction point of an electronic circuit is shown.

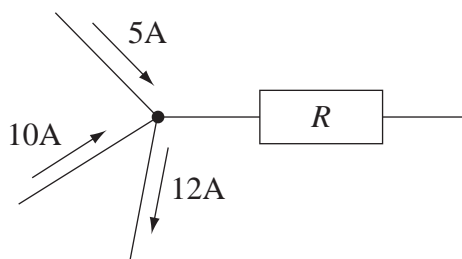

What is the current through resistor R ?

- (A) 3A
(B) 5A
(C) 15A
(D) 27A
- 8 Three capacitors are wired in series as shown. Their individual capacitances are $47\ \mu\text{F}$, $10\ \mu\text{F}$ and $2.2\ \mu\text{F}$.

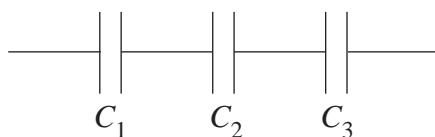

Use the formulae provided to determine their effective capacitance.

$$C_T = C_1 + C_2 + C_3 + \dots$$

$$\frac{1}{C_T} = \frac{1}{C_1} + \frac{1}{C_2} + \frac{1}{C_3} + \dots$$

- (A) $0.6\ \mu\text{F}$
(B) $1.7\ \mu\text{F}$
(C) $34.8\ \mu\text{F}$
(D) $59.2\ \mu\text{F}$

- 9 The resistance value of a large batch of $1\text{k}\Omega$ carbon resistors was checked using a multimeter. The lowest resistance reading was measured as 950Ω while the highest resistance reading was measured as 1050Ω .

What is the most probable cause of the variation in the resistance readings?

- (A) Some of the resistors were faulty.
- (B) The operator made an error in reading the multimeter.
- (C) This batch of resistors has a value tolerance of $\pm 0.05\%$.
- (D) This batch of resistors has a value tolerance of $\pm 5\%$.

- 10 The input waveforms at A and B for a logic circuit are shown.

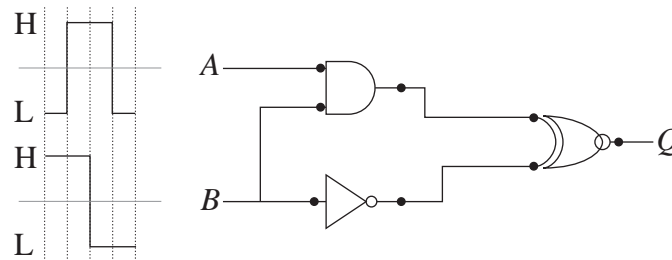

What is the resulting output waveform at Q ?

- (A)
- (B)
- (C)
- (D)

BLANK PAGE

BLANK PAGE

BLANK PAGE



2010 HIGHER SCHOOL CERTIFICATE EXAMINATION

Industrial Technology Electronics Technologies

--	--	--	--	--

Centre Number

Section II

--	--	--	--	--	--	--	--	--

Student Number

15 marks

Attempt Questions 11–16

Allow about 35 minutes for this section

Answer the questions in the spaces provided. These spaces provide guidance for the expected length of response.

Use the block diagram shown to answer Question 11 and Question 12.

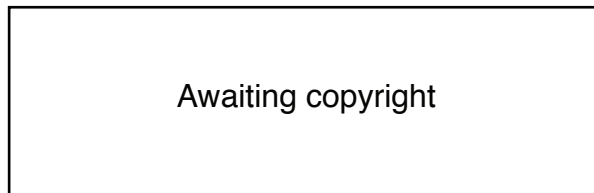

Question 11 (1 mark)

What is the function of the LDR sensor?

1

.....

.....

.....

.....

Question 12 (2 marks)

S-R bistable circuits used in this alarm security system usually include a switch as shown.

2



Why is this switch necessary?

.....

.....

.....

.....

.....

.....

Question 13 (2 marks)

Why is the digital simulation of electronic circuits a useful design tool?

2

.....

.....

.....

.....

.....

.....

Question 14 (3 marks)

Describe the difference between the operating properties of bipolar transistors and field effect transistors.

3

.....

.....

.....

.....

.....

.....

.....

.....

.....

.....

.....

.....

.....

.....

.....

.....

Question 15 (3 marks)

An electrical circuit is shown. The current passing through $R_4 = 0.9\text{A}$.

3

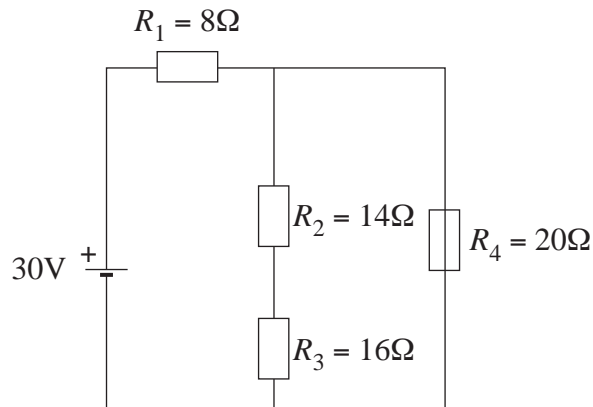

$$R_T = R_1 + R_2 + R_3 + \dots$$

$$\frac{1}{R_T} = \frac{1}{R_1} + \frac{1}{R_2} + \frac{1}{R_3} + \dots$$

$$V = IR$$

$$P = VI$$

Use the formulae provided to calculate the power dissipated by resistor R_3 .

.....

.....

.....

.....

.....

.....

.....

.....

.....

.....

.....

.....

.....

.....

.....

Question 16 (4 marks)

An electronic circuit operates so that a bulb remains turned on for a few seconds after a control switch has turned it off.

4

Design and explain the operation of this electronic circuit.

Use the partially completed circuit provided to answer this question.

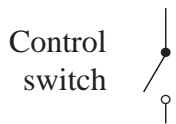

.....

.....

.....

.....

.....

.....

.....

.....

.....

.....

.....

.....

.....

.....

.....

.....

.....

.....

.....

.....

.....

BLANK PAGE

BLANK PAGE

BLANK PAGE

**Industrial Technology
Electronics Technologies**

Section III

15 marks

Attempt Question 17

Allow about 35 minutes for this section

Answer the question in a writing booklet provided. Extra writing booklets are available.

Question 17 (15 marks)

A small family-owned company is operating successfully in a local market. The company is assessing the feasibility of relocating to a larger facility in order to expand production.

- (a) Outline environmental considerations that may affect the expansion of the company. **3**

- (b) Analyse the structural, technical and personnel issues to be considered prior to relocating and expanding. **12**

End of paper

BLANK PAGE