

**B O A R D O F S T U D I E S**  
NEW SOUTH WALES

**2010**

**HIGHER SCHOOL CERTIFICATE  
EXAMINATION**

# Industrial Technology

## Graphics Technologies

### General Instructions

- Reading time – 5 minutes
- Working time –  $1\frac{1}{2}$  hours
- Write using black or blue pen
- Draw diagrams using pencil
- Board-approved calculators may be used
- Write your Centre Number and Student Number at the top of page 9

**Total marks – 40**

**Section I** Pages 2–6

**10 marks**

- Attempt Questions 1–10
- Allow about 20 minutes for this section

**Section II** Pages 9–12

**15 marks**

- Attempt Questions 11–15
- Allow about 35 minutes for this section

**Section III** Page 13

**15 marks**

- Attempt Question 16
- Allow about 35 minutes for this section

## Section I

10 marks

Attempt Questions 1–10

Allow about 20 minutes for this section

Use the multiple-choice answer sheet for Questions 1–10.

---

1 What type of pictorial drawing is shown?

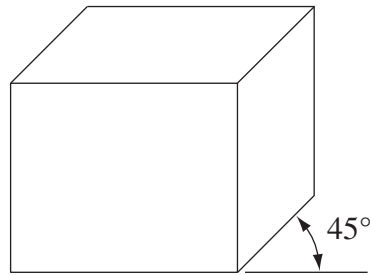

- (A) Axonometric
  - (B) Oblique
  - (C) Orthographic
  - (D) Perspective
- 2 What does AS1100.301 refer to?
- (A) Drawing standards used in engineering
  - (B) Australian Schools' Standard for drawing
  - (C) Drawing standards used in mechanical drawing
  - (D) Drawing standards used in architectural drawing

3 How is a section line in a drawing indicated?

(A) 

(B) 

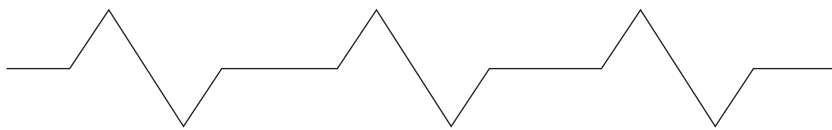
(C) 

(D) 

4 A house plan has been drawn to a scale of 1:100.

If a measurement is 4.5 metres in real life, how long would it be on the house plan?

(A) 4.5 mm

(B) 45 mm

(C) 450 mm

(D) 4500 mm

5 A drawing of a metal joint is shown.

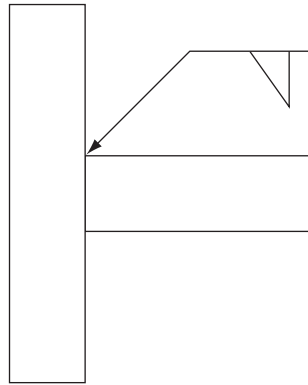

What type of weld is indicated by the symbol?

- (A) Butt
- (B) CT
- (C) Fillet
- (D) Single V-butt

6 Which of the following sectional drawings correctly shows a counter-sunk threaded blind hole?

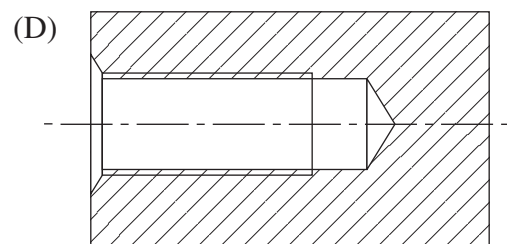
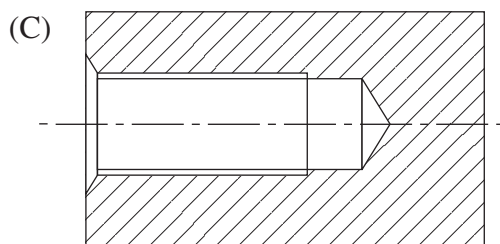
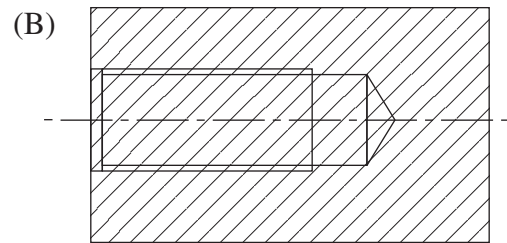
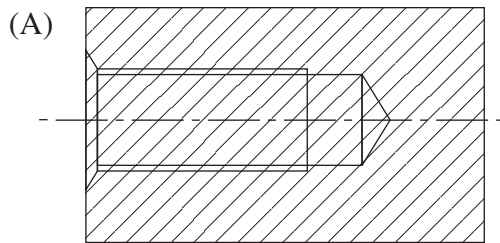

Use the floor plan to answer Questions 7–8.

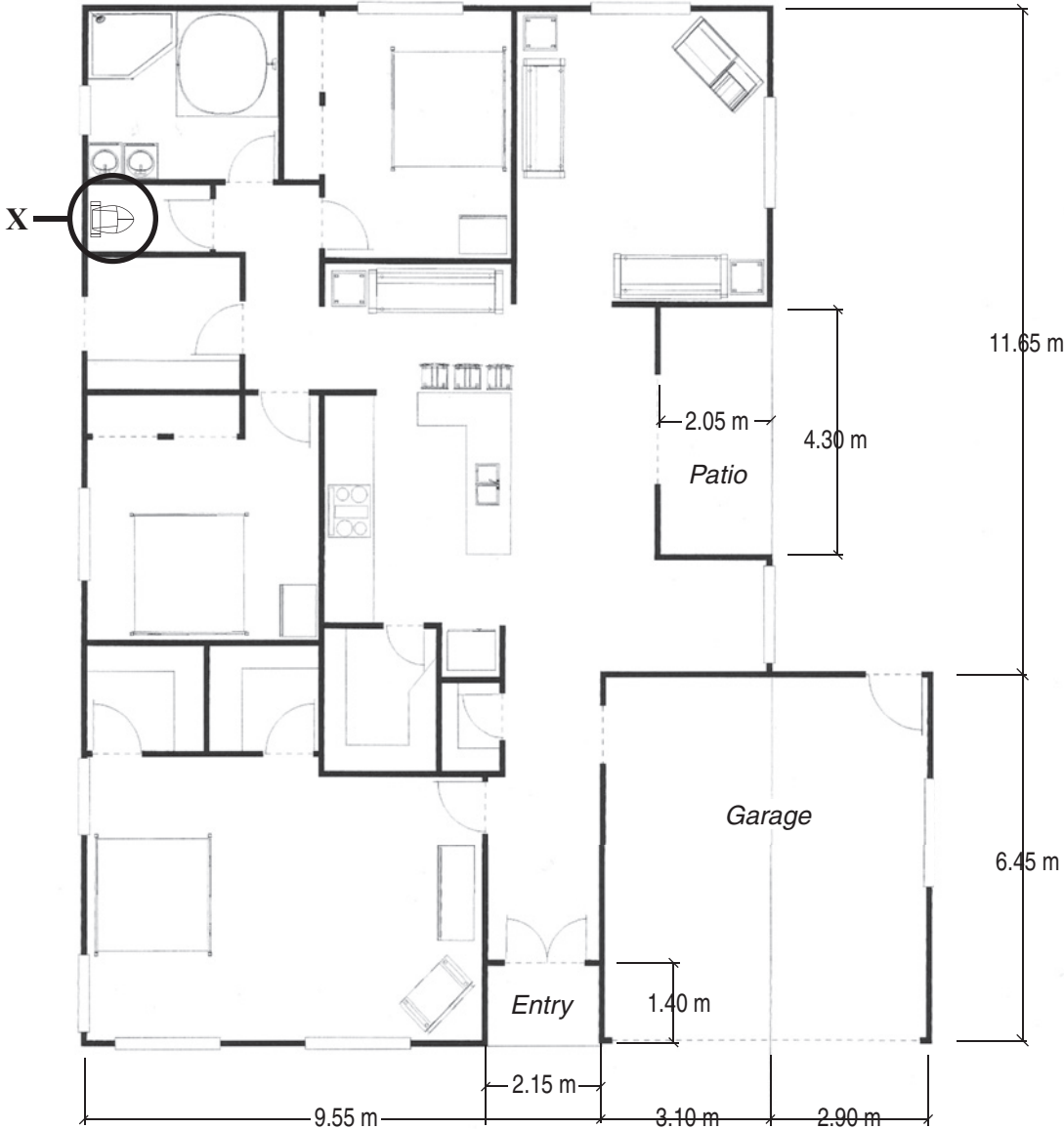

- 7 What does the symbol indicated at **X** on the floor plan indicate?
- (A) Hand basin
  - (B) Kitchen sink
  - (C) Laundry sink
  - (D) Water closet
- 8 What is the approximate area of the house (including garage, patio and entry) in square metres?
- (A) 229 m<sup>2</sup>
  - (B) 239 m<sup>2</sup>
  - (C) 248 m<sup>2</sup>
  - (D) 268 m<sup>2</sup>

9 A drawing of a step block is shown with dimensions marked.

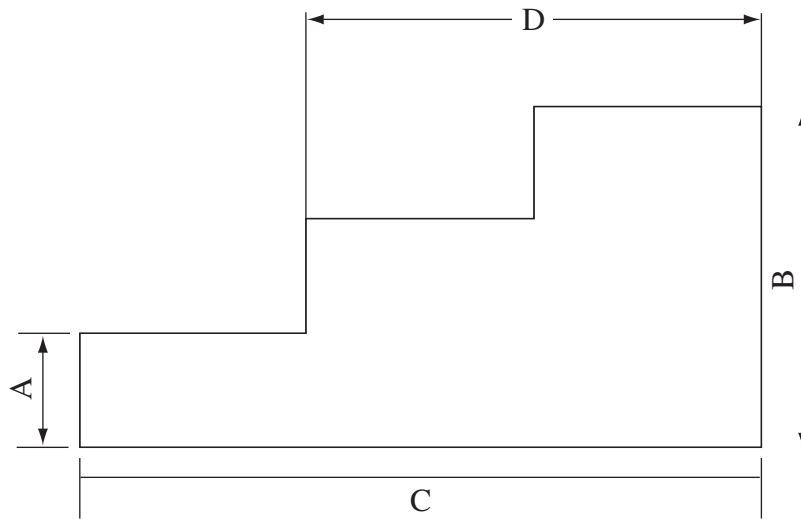

Which distance is correctly dimensioned?

- (A) A
- (B) B
- (C) C
- (D) D

10 Which of the following correctly indicates first-angle projection?

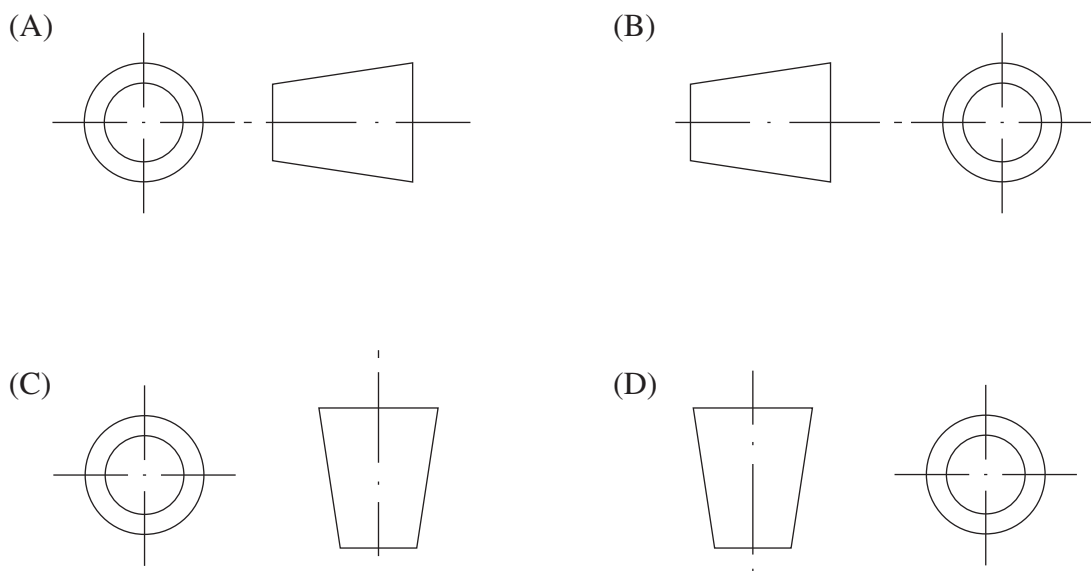

BLANK PAGE

BLANK PAGE





2010 HIGHER SCHOOL CERTIFICATE EXAMINATION

# Industrial Technology Graphics Technologies

--	--	--	--	--

Centre Number

## Section II

--	--	--	--	--	--	--	--	--

Student Number

15 marks

Attempt Questions 11–15

Allow about 35 minutes for this section

Answer the questions in the spaces provided. These spaces provide guidance for the expected length of response.

---

### Question 11 (3 marks)

Identify TWO advantages and TWO disadvantages of using CAD programs in the production of drawings. **3**

.....

.....

.....

.....

.....

.....

.....

.....

.....

.....

.....

.....

**Question 12** (2 marks)

Render the drawing of the billiard ball shown to give a three dimensional effect. There is a light source located behind the ball at 45°.

2

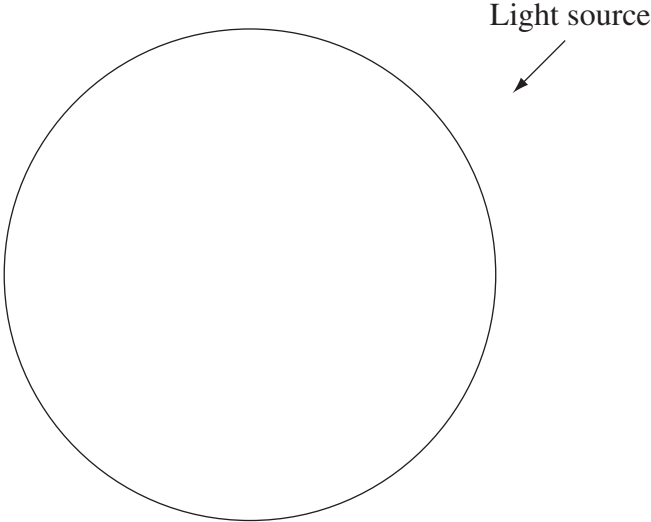

**Question 13** (3 marks)

Outline the processes used by an architectural firm to develop a design from concept to council submission.

3

.....

.....

.....

.....

.....

.....

.....

.....

.....

.....

.....

.....

.....

.....

.....

.....

**Question 14** (3 marks)

Complete detailed orthographic views of the drawing below. The views are to be drawn to full size. Include overall dimensions and hidden detail lines.

**3**

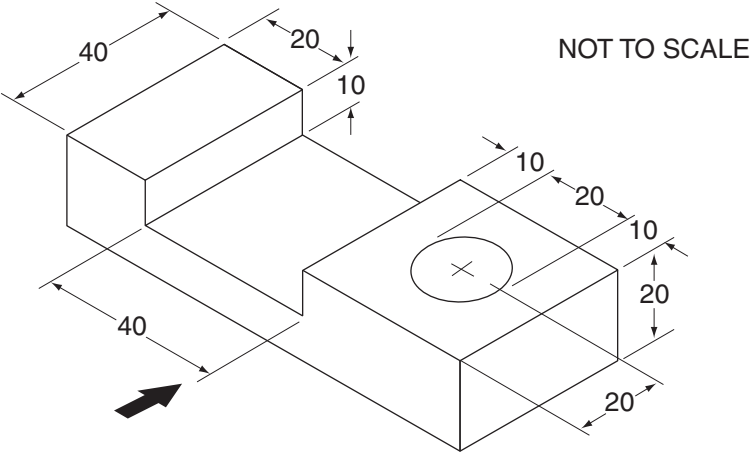

**Question 15** (4 marks)

A drawing of a machine block is shown. Sketch a full size isometric view using the starting points indicated.

4

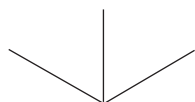
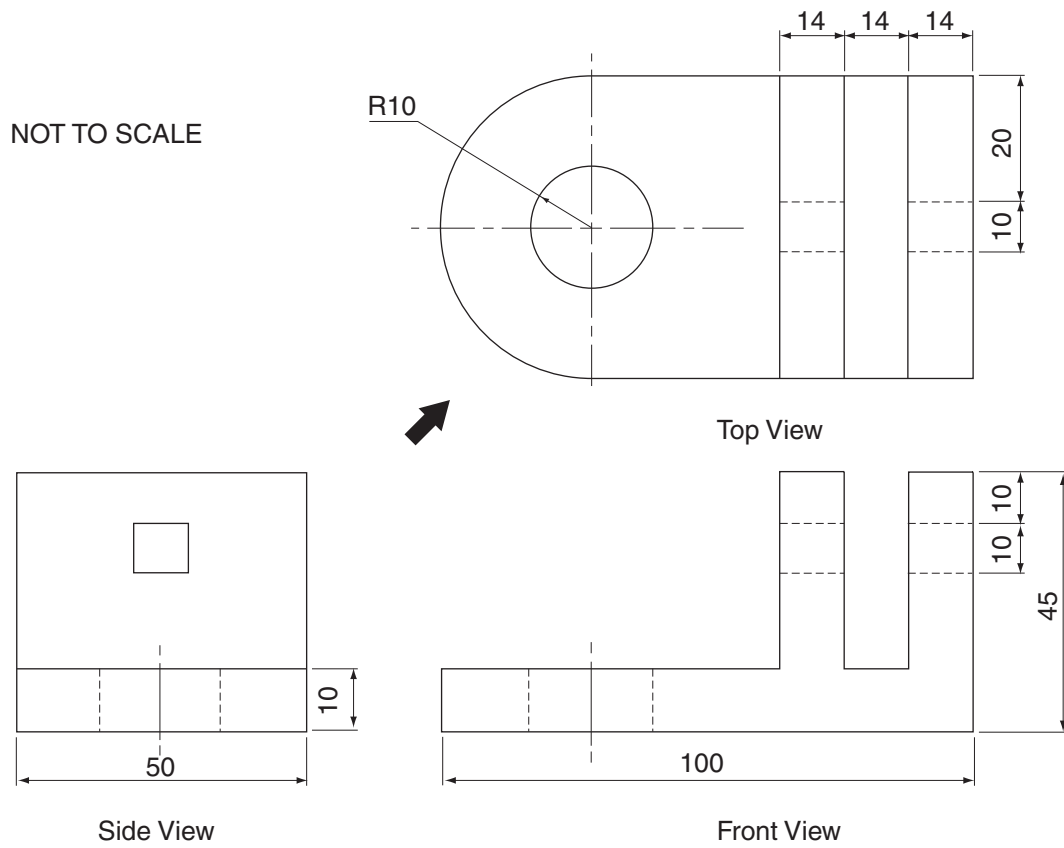

# Industrial Technology Graphics Technologies

## Section III

15 marks

Attempt Question 16

Allow about 35 minutes for this section

Answer the question in a writing booklet provided. Extra writing booklets are available.

---

### Question 16 (15 marks)

A small family-owned company is operating successfully in a local market. The company is assessing the feasibility of relocating to a larger facility in order to expand production.

- (a) Outline environmental considerations that may affect the expansion of the company. **3**
  
- (b) Analyse the structural, technical and personnel issues to be considered prior to relocating and expanding. **12**

**End of paper**

BLANK PAGE