

B O A R D O F S T U D I E S
NEW SOUTH WALES

2011

**HIGHER SCHOOL CERTIFICATE
EXAMINATION**

Physics

General Instructions

- Reading time – 5 minutes
- Working time – 3 hours
- Write using black or blue pen
Black pen is preferred
- Draw diagrams using pencil
- Board-approved calculators may be used
- A data sheet, formulae sheets and Periodic Table are provided at the back of this paper
- Write your Centre Number and Student Number at the top of pages 9, 13, 15, 19 and 21

Total marks – 100

Section I Pages 2–22

75 marks

This section has two parts, Part A and Part B

Part A – 20 marks

- Attempt Questions 1–20
- Allow about 35 minutes for this part

Part B – 55 marks

- Attempt Questions 21–30
- Allow about 1 hour and 40 minutes for this part

Section II Pages 23–30

25 marks

- Attempt ONE question from Questions 31–35
- Allow about 45 minutes for this section

Section I

75 marks

Part A – 20 marks

Attempt Questions 1–20

Allow about 35 minutes for this part

Use the multiple-choice answer sheet for Questions 1–20.

- 1 What is the main cause of orbital decay of a satellite in low Earth orbit?
- (A) Tidal effects of the Moon
 - (B) The Sun's gravitational field
 - (C) Friction between the atmosphere and the satellite
 - (D) The interaction of the solar wind with the satellite
- 2 A 60 kg object has a weight of 240 N on the surface of Planet X.
- What is the acceleration due to gravity on the surface of Planet X?
- (A) 0.25 m s^{-2}
 - (B) 4 m s^{-2}
 - (C) 250 m s^{-2}
 - (D) $14\,400 \text{ m s}^{-2}$
- 3 Metals have a crystal lattice structure.
- What part of the metal's structure does the lattice represent?
- (A) The number of Cooper pairs
 - (B) The location of the metal ions
 - (C) The position of the free electrons
 - (D) The energy gap below the conduction band
- 4 Why are insulators poor conductors of electricity?
- (A) Insulators do not have a conduction band.
 - (B) The valence bands of insulators do not contain any electrons.
 - (C) Insulators have a large energy band gap and a full valence band.
 - (D) Insulators have a small energy band gap and a partly filled conduction band.

- 5 Which law best applies to the operation of an electrical transformer?
- (A) Conservation of Mass
 (B) Conservation of Energy
 (C) Conservation of Charge
 (D) Conservation of Momentum
- 6 Why is the back emf induced in a motor greater when the motor is rotating faster?
- (A) A larger current is induced.
 (B) It takes a greater emf to spin the motor.
 (C) The rate of change of magnetic flux is greater.
 (D) More magnetic field lines are being cut per rotation.
- 7 Two parallel plates are 2 mm apart and have a potential difference of 100 V between them. An electron is placed halfway between the plates.

What is the magnitude of the force on the electron?

- (A) 8.0×10^{-18} N
 (B) 1.6×10^{-17} N
 (C) 8.0×10^{-15} N
 (D) 1.6×10^{-14} N
- 8 A rocket is launched. Its engine produces a constant thrust for the first 10 seconds and is then switched off.

Which graph best illustrates the g-force experienced by an astronaut in the rocket?

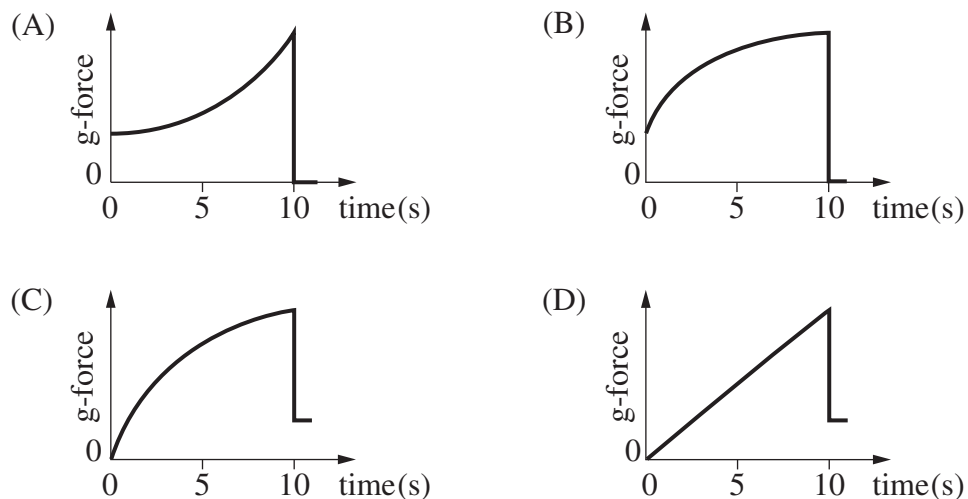

- 9 The diagram shows a stationary spacecraft next to a building, as seen by an observer across the street.

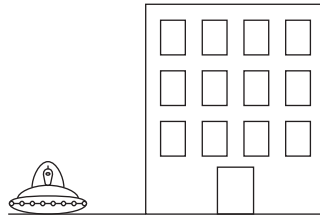

A short time later the spacecraft is observed to be travelling vertically upwards at $0.8c$, relative to the building.

Which diagram best represents the appearance of the moving spacecraft, as seen by the observer?

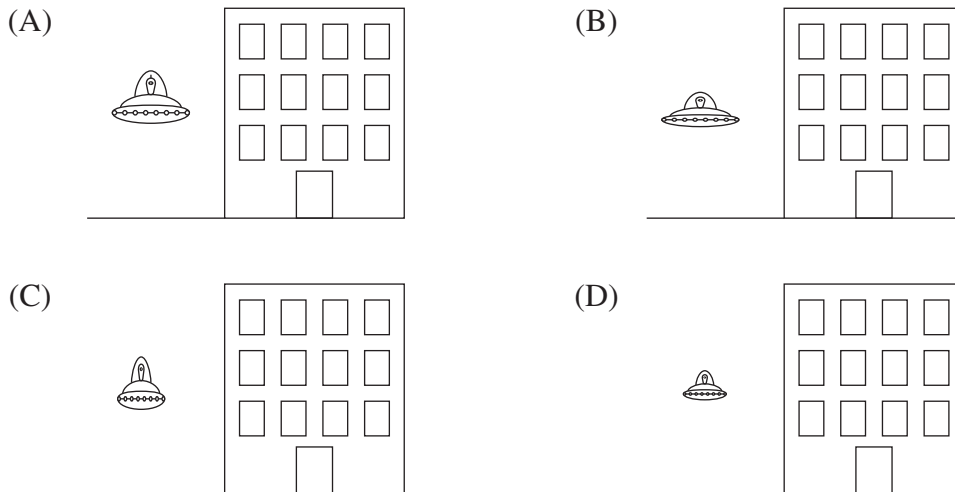

- 10 A student performed an experiment using two identical metal rods connected to a power supply. Rod A was placed at different distances from Rod B, and the measurements on the electronic balance were recorded.

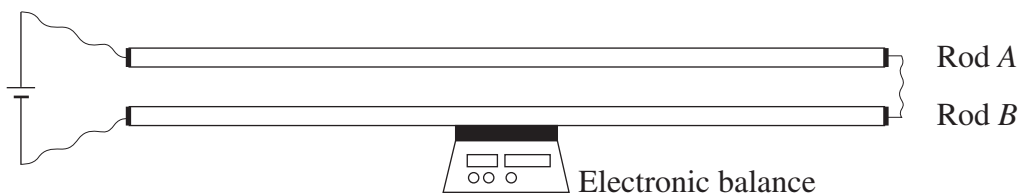

Which is the independent variable?

- (A) The length of the rods
- (B) The current in Rod A
- (C) The mass recorded on the balance
- (D) The distance between the two rods

11 A student set up the equipment shown to carry out a first-hand investigation.

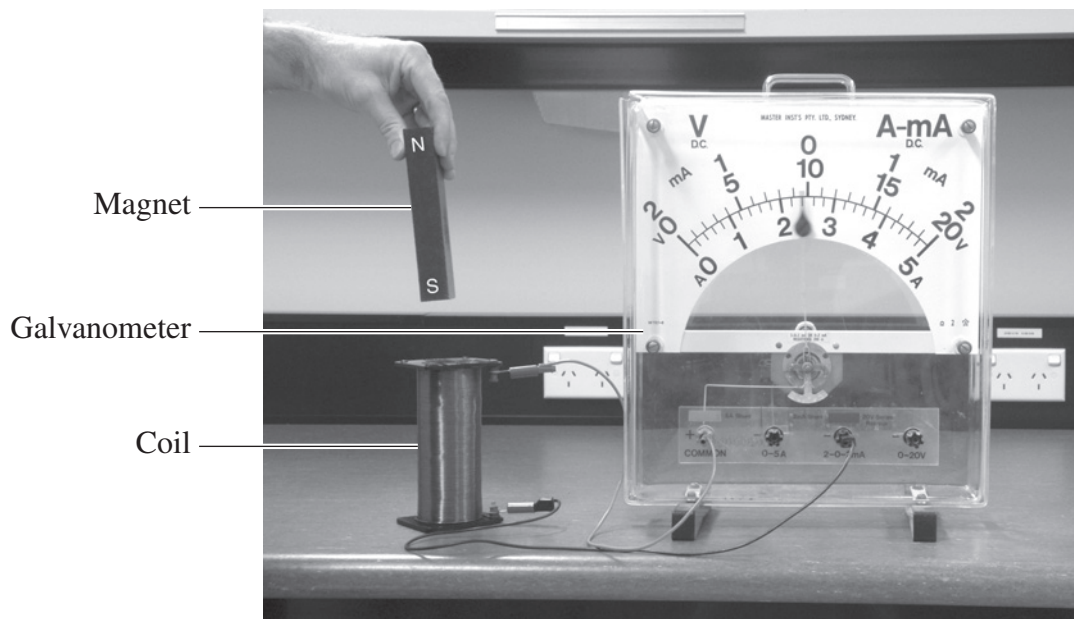

What was the student investigating?

- (A) Gravity
- (B) The motor effect
- (C) Magnetic levitation
- (D) Electromagnetic induction

12 The diagram represents a DC electric motor.

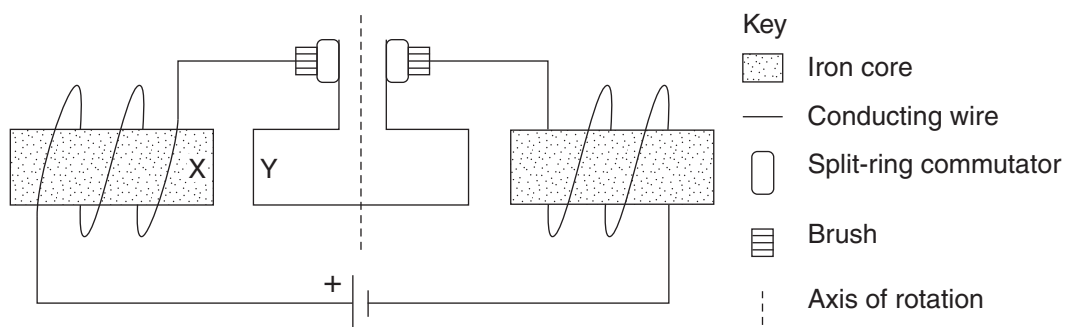

What is the polarity of the magnetic pole at X, and the direction of the motion of wire Y?

	<i>Polarity of magnetic pole at X</i>	<i>Direction of motion of wire Y</i>
(A)	South	Into the page
(B)	South	Out of the page
(C)	North	Into the page
(D)	North	Out of the page

13 A sample of pure silicon is doped with arsenic.

How does the electrical conductivity of the doped silicon change, and for what reason?

	<i>Change in electrical conductivity</i>	<i>Reason</i>
(A)	Increases	Increased number of free electrons
(B)	Increases	Increased number of holes
(C)	Decreases	Decreased number of free electrons
(D)	Decreases	Decreased number of holes

14 A heavy copper split ring is attached by a light insulating rod to a pivot to form a pendulum. A region of uniform magnetic field B is present as shown. As the pendulum swings from Position 1 to Position 2, the induced emf in the ring is measured between points X and Y .

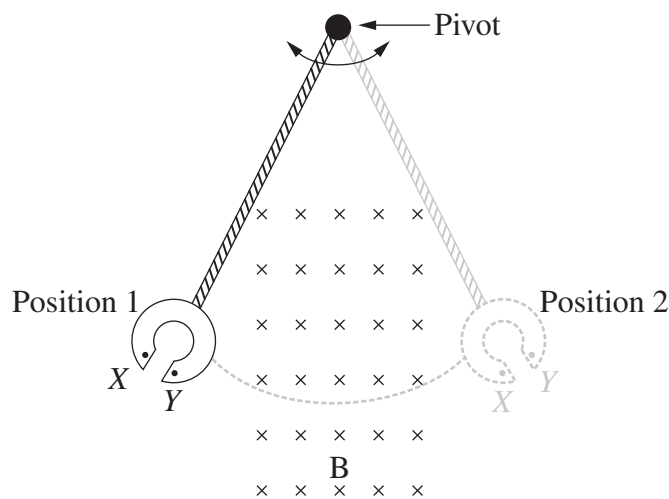

Which graph best represents the measured emf during the time that the pendulum swings from Position 1 to Position 2?

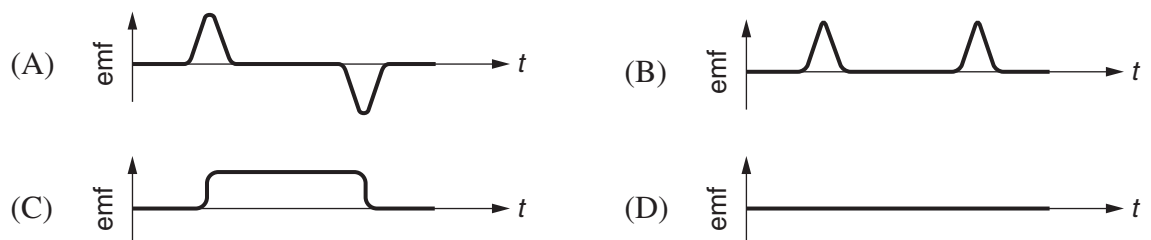

15 A marble rolls off a 1.0 m high horizontal table with an initial velocity of 4.0 m s^{-1} .

How long will it take the marble to hit the floor?

- (A) 0.20 s
- (B) 0.25 s
- (C) 0.45 s
- (D) 3.20 s

16 A satellite is orbiting a planet at a constant speed.

Which of the following statements is correct?

- (A) The satellite is not accelerating.
- (B) The orbit of the satellite has a fixed radius.
- (C) Fuel must be used to supply a constant thrust to the satellite.
- (D) The centripetal force on the satellite is balanced by the gravitational force.

17 When photons with energy E strike a metal surface, electrons may be emitted.

The maximum kinetic energy (E_k) of the electrons is given by $E_k = E - W$ where W is a constant for the metal.

Which of the following graphs shows the relationship between the maximum kinetic energy of these electrons (E_k) and the wavelength of the photons (λ)?

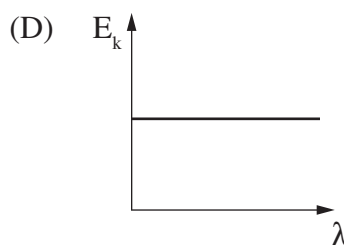
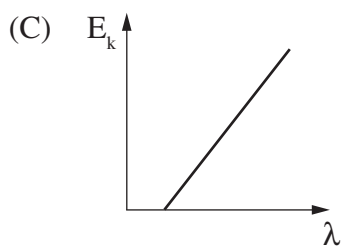
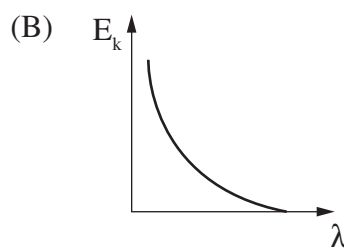
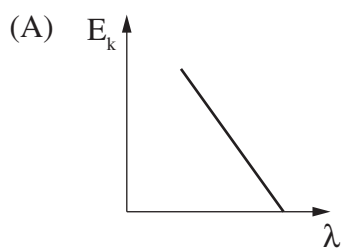

- 18 An electric motor is constructed using a square coil and a uniform magnetic field of strength 0.45 T. The coil has 3 turns and sides of 10 cm. A current of 0.5 A flows through the coil.

What is the maximum torque experienced by the coil as it rotates?

- (A) 2.25×10^{-3} Nm
(B) 6.75×10^{-3} Nm
(C) 22.5 Nm
(D) 67.5 Nm
- 19 An electron, e , travelling with a velocity, v , passes through an electric field, E , between two parallel plates.

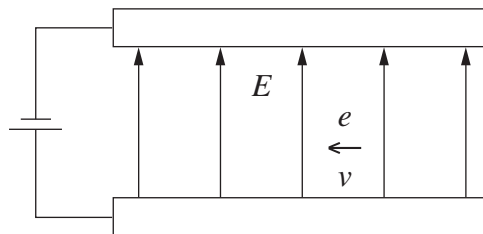

What is the direction of the force that this electric field exerts on the electron?

- (A) \uparrow
(B) \nwarrow
(C) \swarrow
(D) \downarrow
- 20 A satellite, initially in a low Earth orbit, is moved to a new orbit where its gravitational potential energy is half its initial value.

What is the gravitational force experienced by the satellite in its new orbit?

- (A) Half the initial force
(B) Twice the initial force
(C) Four times the initial force
(D) One quarter the initial force

Physics

--	--	--	--	--

Centre Number

Section I (continued)

--	--	--	--	--	--	--	--	--

Student Number

Part B – 55 marks

Attempt Questions 21–30

Allow about 1 hour and 40 minutes for this part

Answer the questions in the spaces provided. These spaces provide guidance for the expected length of response.

Show all relevant working in questions involving calculations.

Question 21 (5 marks)

Please turn over

Question 21 (5 marks)

The electrical resistance, R , of a piece of wire was measured at different temperatures, T . Near room temperature, the resistance of the wire can be modelled by the equation $R = mT + b$.

Temperature ($^{\circ}\text{C}$)	Resistance (ohms)
12	0.122
16	0.125
32	0.129
36	0.131

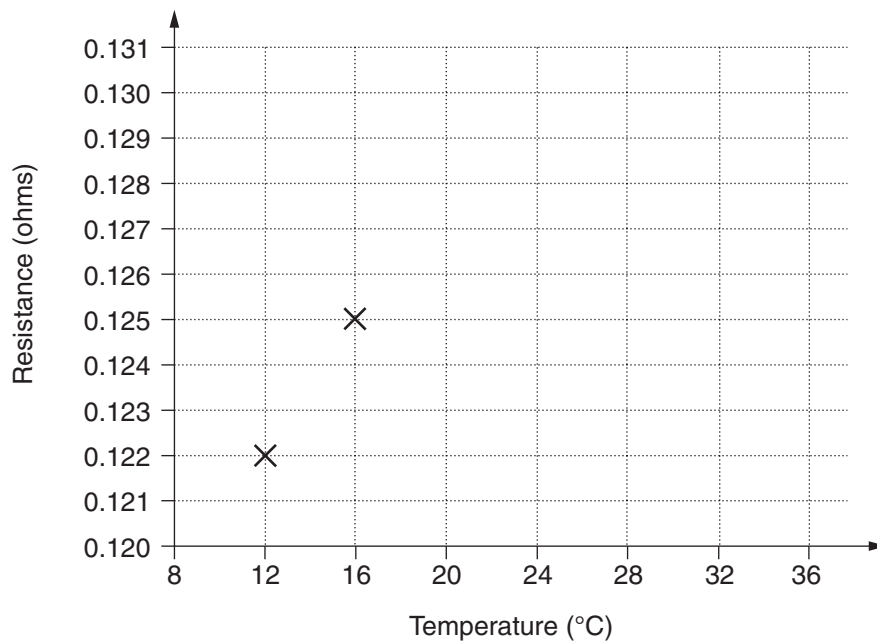

- (a) Plot the TWO remaining data points on the graph provided. Draw a line of best fit on the graph and use it to estimate the electrical resistance of the wire at 24°C . **3**

.....

- (b) Assess the validity of using the data from this experiment to estimate the electrical resistance at -100°C . **2**

.....

Question 22 (5 marks)

- (a) What was the purpose of the experiment that Michelson and Morley conducted in 1887? **1**

.....
.....

- (b) Draw a labelled diagram that outlines how the experiment was performed. **4**

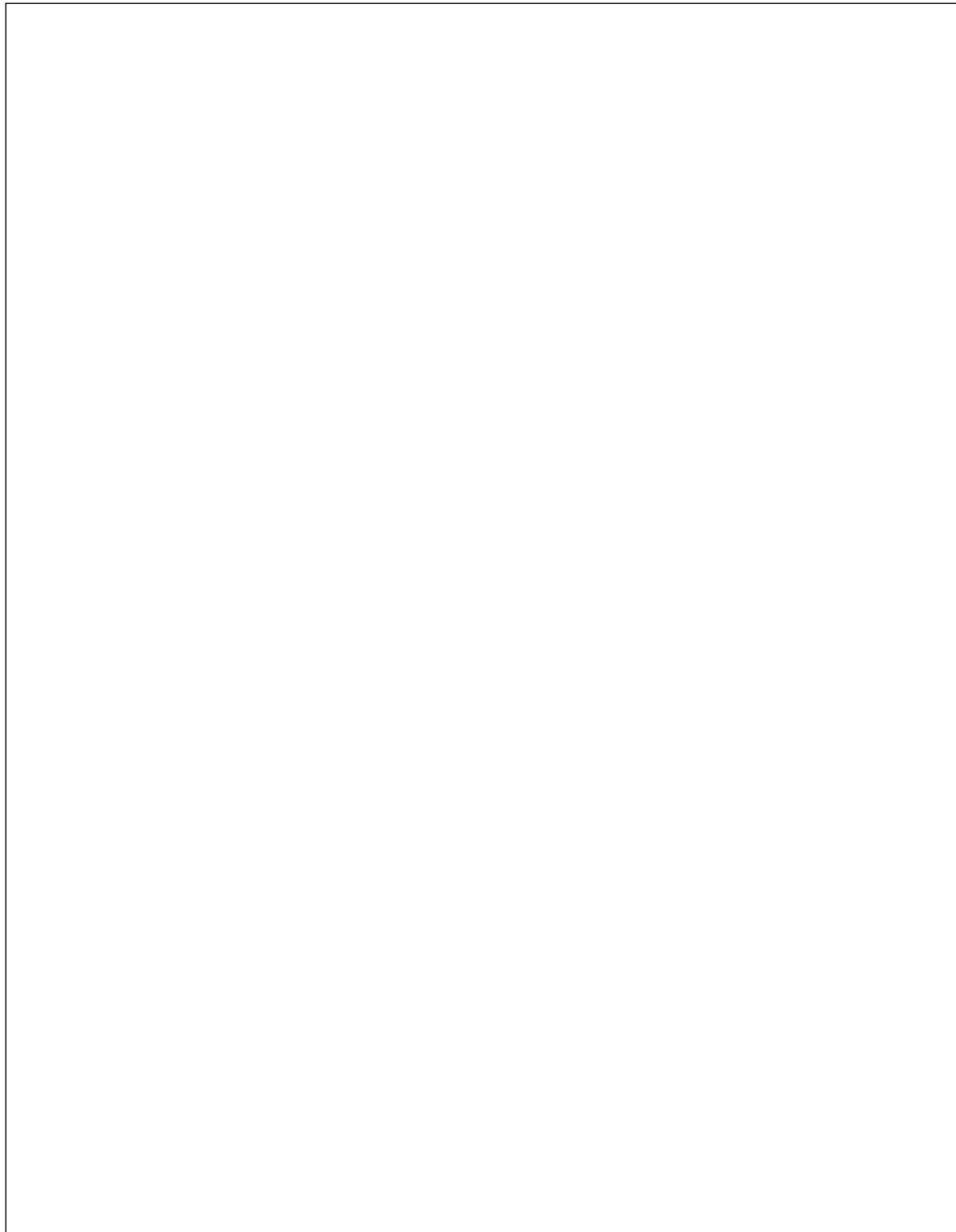

BLANK PAGE



--	--	--	--	--

Centre Number

Section I – Part B (continued)

--	--	--	--	--	--	--	--	--

Student Number

Question 23 (7 marks)

A rocket launches a satellite into an orbit 350 km above Earth’s surface. The weight of the satellite is 14.0 kN at launch, and is 12.6 kN when in orbit.

(Radius of Earth = 6380 km, mass of Earth = 5.97×10^{24} kg)

- (a) Why does the weight of the satellite change? 1

.....

- (b) Calculate the orbital velocity of this satellite. 2

.....
.....
.....
.....
.....

- (c) Explain TWO effects that a reduction in altitude would have on the motion of this satellite. 4

.....
.....
.....
.....
.....
.....
.....
.....
.....

Question 24 (4 marks)

4

Consider the following ‘thought experiment’.

A scientist on board a spaceship wishes to synchronise two clocks. To achieve this, beams of light from a source placed midway between the clocks activate photocells, turning on both clocks.

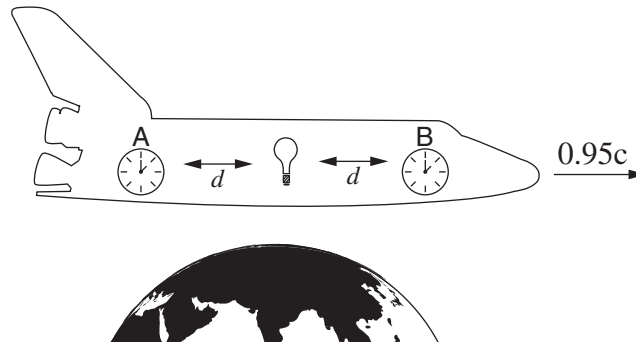

The scientist observes the synchronisation of the clocks as the rocket flies past Earth at $0.95c$. A person on Earth observes that the clocks are not synchronised. Account for these observations.

.....

.....

.....

.....

.....

.....

.....

.....

--	--	--	--	--

Centre Number

Section I – Part B (continued)

--	--	--	--	--	--	--	--	--	--

Student Number

Question 25 (4 marks)

Identical magnets *A* and *B* are suspended above vertical copper tubes as shown in the diagram.

4

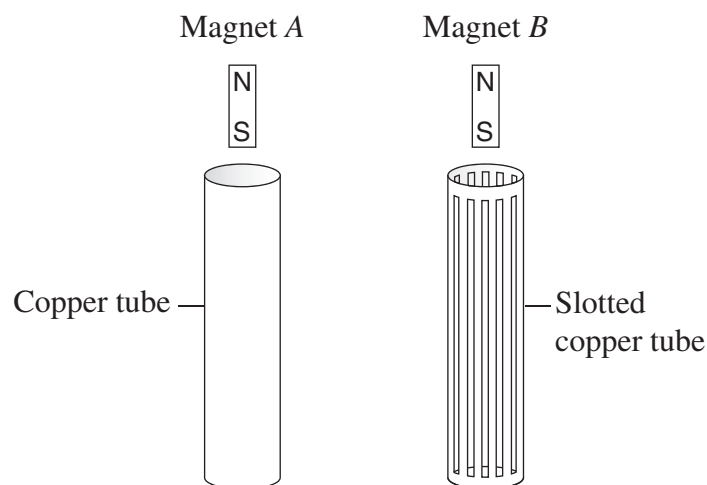

The magnets are dropped at the same time. Each magnet falls straight through its tube without touching the tube walls.

Which magnet leaves its tube first and why?

.....

.....

.....

.....

.....

.....

.....

.....

.....

.....

.....

Question 26 (9 marks)

- (a) Use a flowchart to show how electrical energy is transferred from a power station to its point of use.

3



Question 26 continues on page 17

BLANK PAGE

--	--	--	--	--

Centre Number

Section I – Part B (continued)

--	--	--	--	--	--	--	--	--	--

Student Number

Question 27 (4 marks)

A single turn coil is positioned in a region of uniform magnetic field with a strength of 0.2 T. The plane of the coil is at 45° to the magnetic field. The coil is a square with 5 cm sides, and carries a current of 10.0 A.

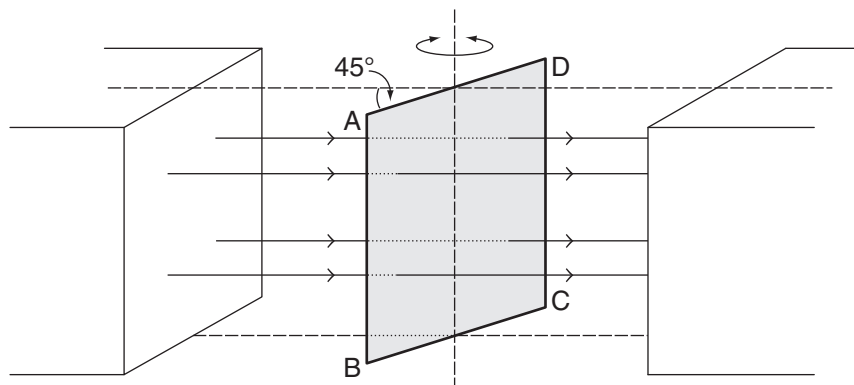

- (a) Calculate the magnitude of the force on side AB. 2

.....

.....

.....

- (b) Explain why the net force produced by the magnetic field on the coil is zero. 2

.....

.....

.....

Question 28 (6 marks)

- (a) How could a student test the hypothesis that cathode rays are streams of particles? In your answer refer to the results that would be observed. **3**

.....

.....

.....

.....

.....

.....

.....

- (b) How is an electron beam produced in an electron gun? **3**

.....

.....

.....

.....

.....

.....

.....



--	--	--	--	--

Centre Number

Section I – Part B (continued)

--	--	--	--	--	--	--	--	--

Student Number

Question 29 (5 marks)

- (a) Calculate the number of photons, $\lambda = 450 \text{ nm}$, which are required to transfer $1.0 \times 10^{-3} \text{ J}$ of energy. 3

.....

.....

.....

.....

.....

.....

.....

- (b) A 1 W beam of light transfers 1 J per second from one point to another. 2

With reference to the particle model of light, contrast a 1 W beam of red light and a 1 W beam of blue light.

.....

.....

.....

.....

.....

Question 30 (6 marks)

The graph shows the relationship between the resistance of a metal alloy sample and its temperature.

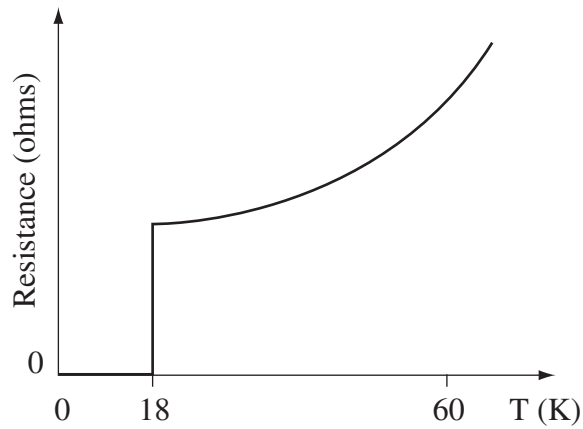

- (a) Why is the resistance of the sample higher at 60 K than at 30 K? 2

.....

.....

.....

.....

- (b) Use BCS theory to explain why the resistance of the sample is zero at temperatures below 18 K. 4

.....

.....

.....

.....

.....

.....

.....

.....

.....

.....

Physics

Section II

25 marks

Attempt ONE question from Questions 31–35

Allow about 45 minutes for this section

Answer the parts of the question as indicated in Section II Answer Booklet 1 and Section II Answer Booklet 2.

Extra writing booklets are available.

Show all relevant working in questions involving calculations.

	Pages
Question 31 Geophysics	24
Question 32 Medical Physics	25–26
Question 33 Astrophysics	27
Question 34 From Quanta to Quarks	28
Question 35 The Age of Silicon	29–30

Question 31 — Geophysics (25 marks)

Answer parts (a)–(c) in Section II Answer Booklet 1.

- (a) Describe how geophysicists have reduced the risks from a natural hazard. In your answer, refer to a specific natural hazard and the instruments used to monitor it. **3**
- (b) (i) How is the rate of sea-floor spreading determined from magnetic anomaly measurements? **3**
- (ii) The diagram represents the magnetic anomalies of the oceanic crust in a particular region where the rate of sea-floor spreading is 30 km per million years. **2**

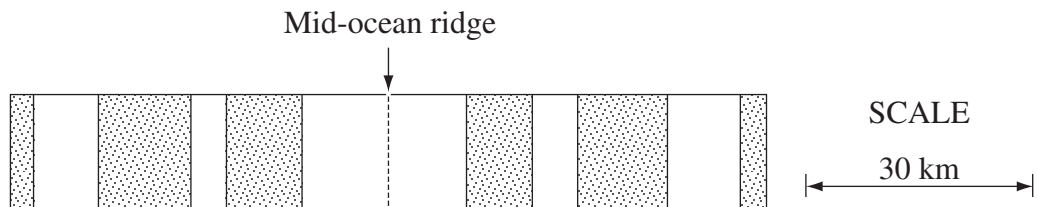

Use this information to construct a graph of magnetic field polarity vs time.

- (c) (i) Describe a first-hand investigation that demonstrates the relationship between the nature of a surface and the radiation reflected from it. **4**
- (ii) How can remote sensing techniques be used to monitor the regrowth of vegetation in regions affected by bushfire? **2**

Answer parts (d)–(e) in Section II Answer Booklet 2.

- (d) (i) Explain why measurements of the gravitational field strength taken on Earth's surface at two different latitudes result in different values. **2**
- (ii) Explain how resource exploration has been aided by the use of gravity methods. **3**
- (e) Explain how seismic methods and a knowledge of wave properties have increased our understanding of the structure of Earth. **6**

Question 32 — Medical Physics (25 marks)

Answer parts (a)–(b) in Section II Answer Booklet 1.

An ultrasound probe fires a pulse of ultrasound into the abdomen as shown in the diagram.

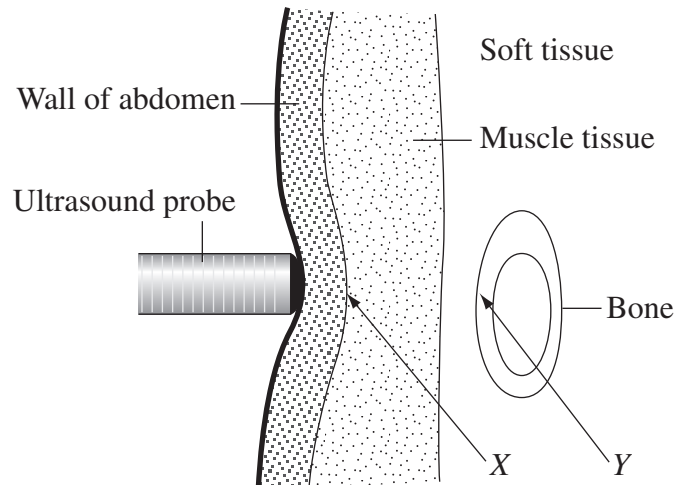

Analysis of the reflected sound produced the following scan.

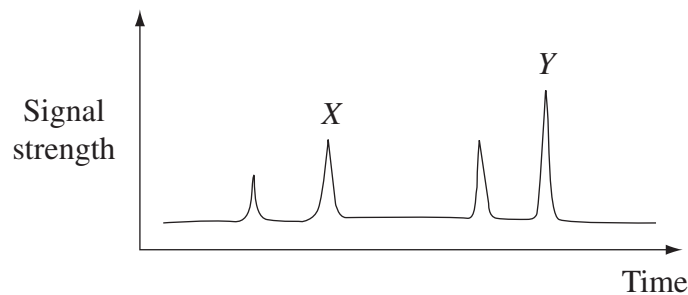

- (a) (i) Identify the type of scan and the information that can be obtained from it. **2**
- (ii) The peaks *X* and *Y* correspond to the ultrasound reflected from the muscle tissue and bone respectively. Explain why the signal strength at *Y* is greater than at *X*. **2**
- (iii) The acoustic impedance of the abdomen wall adjacent to the muscle is $1.56 \times 10^6 \text{ kg m}^{-2} \text{ s}^{-1}$. If muscle tissue has a density of $1.04 \times 10^3 \text{ kg m}^{-3}$ and an acoustic velocity of 1580 m s^{-1} , calculate the percentage of the incident ultrasound pulse that is reflected at boundary *X*. **3**

Question 32 continues on page 26

Question 32 (continued)

- (b) (i) Explain how X-rays are produced in an X-ray tube. **3**
- (ii) The photographs *A* and *B* show scans of the same part of the body. **3**

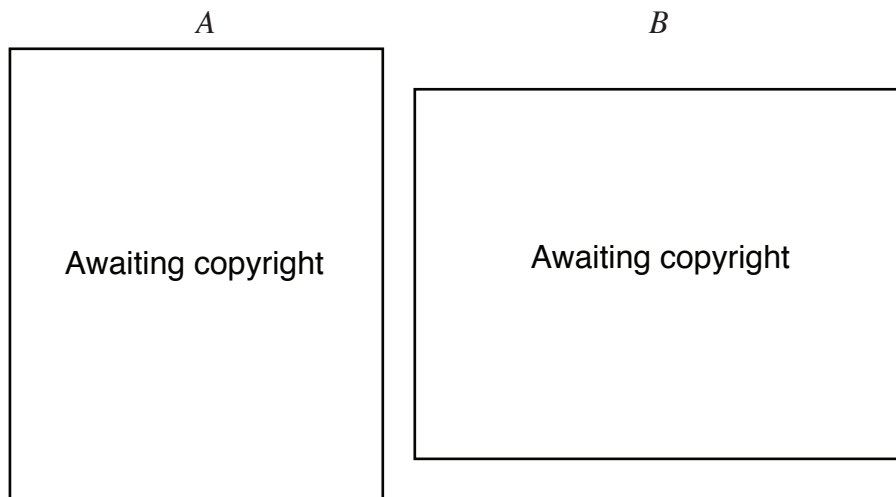

Compare the information provided by the two scans.

Answer parts (c)–(e) in Section II Answer Booklet 2.

- (c) Explain why MRI is an effective tool for diagnosing brain tumours. **3**
- (d) With reference to coherent and incoherent bundles of fibres, explain how an endoscope is used to observe internal organs. **3**
- (e) *An increased understanding of the properties of radioactive isotopes has been important in the development of medical technologies used to analyse bodily processes.* **6**

Justify this statement.

End of Question 32

Question 33 – Astrophysics (25 marks)

Answer parts (a)–(b) in Section II Answer Booklet 1.

- (a) (i) Using a diagram, define the term *parsec*. 2
- (ii) Why was the resolution of Galileo’s telescope more important for his observations than its sensitivity? 3
- (iii) Describe ONE technology that has improved the resolution of telescopes. 2

(b)

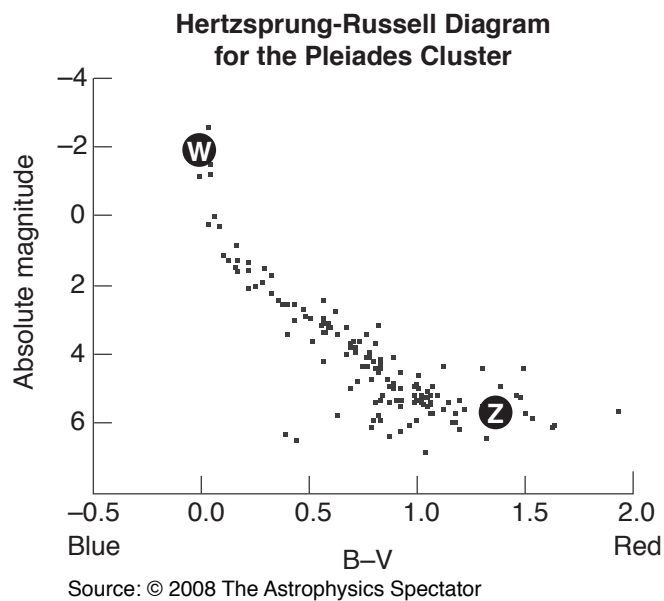

- (i) Compare the nuclear processes in a star found at **W** to a star found at **Z** on the Hertzsprung-Russell diagram. 3
- (ii) In 2008, the distance to the Pleiades cluster was determined as 135 pc. Calculate the apparent magnitude of a star at **W**. 2
- (iii) Calculate the relative brightness of a star found at **W** to a star found at **Z**. 2

Answer parts (c)–(d) in Section II Answer Booklet 2.

- (c) Using a Cepheid and one other named example, explain the difference between intrinsic and extrinsic variable stars. 4
- (d) *Spectroscopy is an important tool in obtaining information about stars, but it is a much more powerful tool when combined with photometry.* 7

Justify this statement.

Question 34 — From Quanta to Quarks (25 marks)

Answer parts (a)–(c) in Section II Answer Booklet 1.

(a) Name a radioisotope used in agriculture and describe its use. **2**

(b) (i) Explain how the reaction rate in a nuclear reactor can be increased or decreased. **4**

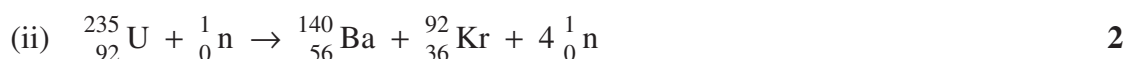

Explain why energy is released in this reaction.

(c) Copy and complete in your booklet the following table comparing forces in the atomic nucleus. **3**

Forces in atomic nucleus			
	<i>Gravitational</i>	<i>Electrostatic</i>	<i>Strong</i>
<i>Strength</i>	Low		
<i>Direction</i>	Attractive		
<i>Range</i>	Infinite		

Answer parts (d)–(g) in Section II Answer Booklet 2.

(d) A cricket ball has a mass of 156 g and a velocity of 20 ms^{-1} . Calculate its de Broglie wavelength. **2**

(e) Identify the types and number of quarks and leptons in a tritium (${}^3_1\text{H}$) atom. **2**

(f) Outline the main contributions of Heisenberg and Pauli to the development of atomic theory. **4**

(g) *Mathematical models, validated by experimental evidence, have improved our understanding of the atom.* **6**

Justify this statement, focusing on the models developed by Bohr and de Broglie.

Question 35 — The Age of Silicon (25 marks)

Answer parts (a)–(d) in Section II Answer Booklet 1.

A circuit for a solar battery charger is shown.

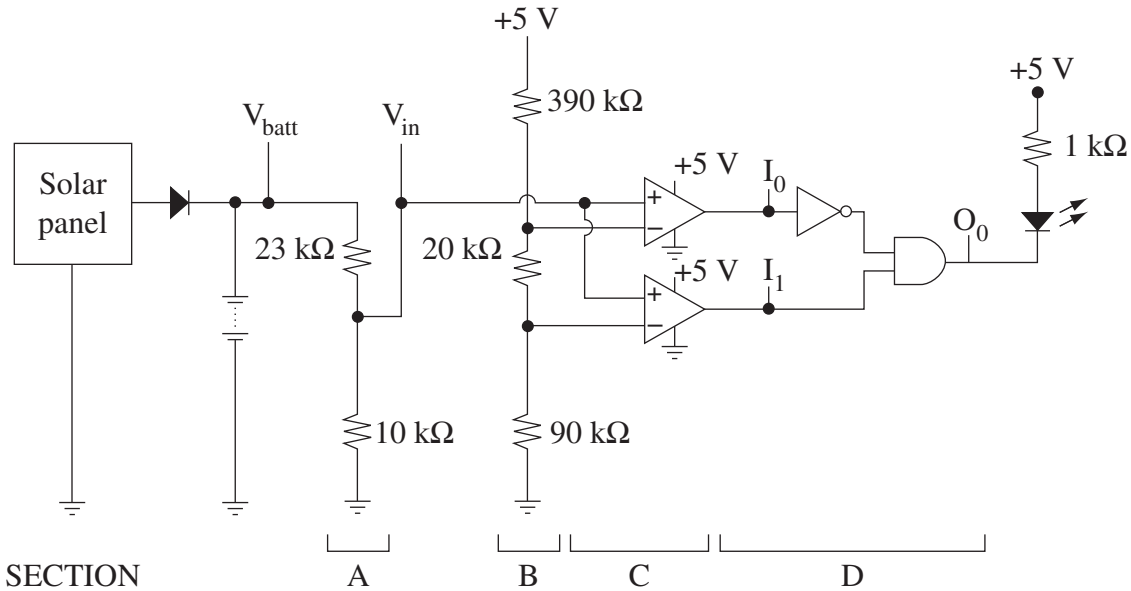

- (a) Construct a truth table for the logic circuit contained in Section D. 3
- (b) Explain whether the operational amplifiers in Section C of the circuit are used in an open loop or closed loop configuration. 2
- (c) Determine the formula relating V_{batt} to V_{in} . 2
- (d) Calculate the range of voltages for V_{batt} for which the LED indicator lights up. 3

Question 35 continues on page 30

Question 35 (continued)

Answer parts (e)–(g) in Section II Answer Booklet 2.

- (e) (i) Using a labelled diagram, describe the construction of an LED. **3**
- (ii) Identify ONE advantage and ONE disadvantage of using LEDs for household lighting. **2**
- (f) What properties of silica make it a suitable material for use in optical fibres? **3**
- (g) The semiconductor integrated circuit industry is rapidly approaching fundamental physics limitations for the design of integrated circuits for computers. **7**

Explain what these limitations are and why this will require a reconceptualisation of the way computers are designed.

End of paper

DATA SHEET

Charge on electron, q_e	$-1.602 \times 10^{-19} \text{ C}$
Mass of electron, m_e	$9.109 \times 10^{-31} \text{ kg}$
Mass of neutron, m_n	$1.675 \times 10^{-27} \text{ kg}$
Mass of proton, m_p	$1.673 \times 10^{-27} \text{ kg}$
Speed of sound in air	340 m s^{-1}
Earth's gravitational acceleration, g	9.8 m s^{-2}
Speed of light, c	$3.00 \times 10^8 \text{ m s}^{-1}$
Magnetic force constant, $\left(k \equiv \frac{\mu_0}{2\pi} \right)$	$2.0 \times 10^{-7} \text{ N A}^{-2}$
Universal gravitational constant, G	$6.67 \times 10^{-11} \text{ N m}^2 \text{ kg}^{-2}$
Mass of Earth	$6.0 \times 10^{24} \text{ kg}$
Planck constant, h	$6.626 \times 10^{-34} \text{ J s}$
Rydberg constant, R (hydrogen)	$1.097 \times 10^7 \text{ m}^{-1}$
Atomic mass unit, u	$1.661 \times 10^{-27} \text{ kg}$ $931.5 \text{ MeV}/c^2$
1 eV	$1.602 \times 10^{-19} \text{ J}$
Density of water, ρ	$1.00 \times 10^3 \text{ kg m}^{-3}$
Specific heat capacity of water	$4.18 \times 10^3 \text{ J kg}^{-1} \text{ K}^{-1}$

FORMULAE SHEET

$$v = f\lambda$$

$$I \propto \frac{1}{d^2}$$

$$\frac{v_1}{v_2} = \frac{\sin i}{\sin r}$$

$$E = \frac{F}{q}$$

$$R = \frac{V}{I}$$

$$P = VI$$

$$\text{Energy} = VIt$$

$$v_{\text{av}} = \frac{\Delta r}{\Delta t}$$

$$a_{\text{av}} = \frac{\Delta v}{\Delta t} \text{ therefore } a_{\text{av}} = \frac{v - u}{t}$$

$$\Sigma F = ma$$

$$F = \frac{mv^2}{r}$$

$$E_k = \frac{1}{2}mv^2$$

$$W = Fs$$

$$p = mv$$

$$\text{Impulse} = Ft$$

$$E_p = -G \frac{m_1 m_2}{r}$$

$$F = mg$$

$$v_x^2 = u_x^2$$

$$v = u + at$$

$$v_y^2 = u_y^2 + 2a_y \Delta y$$

$$\Delta x = u_x t$$

$$\Delta y = u_y t + \frac{1}{2}a_y t^2$$

$$\frac{r^3}{T^2} = \frac{GM}{4\pi^2}$$

$$F = \frac{Gm_1 m_2}{d^2}$$

$$E = mc^2$$

$$l_v = l_0 \sqrt{1 - \frac{v^2}{c^2}}$$

$$t_v = \frac{t_0}{\sqrt{1 - \frac{v^2}{c^2}}}$$

$$m_v = \frac{m_0}{\sqrt{1 - \frac{v^2}{c^2}}}$$

FORMULAE SHEET

$$\frac{F}{l} = k \frac{I_1 I_2}{d}$$

$$d = \frac{1}{p}$$

$$F = BIl \sin \theta$$

$$M = m - 5 \log \left(\frac{d}{10} \right)$$

$$\tau = Fd$$

$$\frac{I_A}{I_B} = 100^{(m_B - m_A)/5}$$

$$\tau = nBIA \cos \theta$$

$$\frac{V_p}{V_s} = \frac{n_p}{n_s}$$

$$m_1 + m_2 = \frac{4\pi^2 r^3}{GT^2}$$

$$F = qvB \sin \theta$$

$$\frac{1}{\lambda} = R \left(\frac{1}{n_f^2} - \frac{1}{n_i^2} \right)$$

$$E = \frac{V}{d}$$

$$\lambda = \frac{h}{mv}$$

$$E = hf$$

$$c = f\lambda$$

$$A_0 = \frac{V_{\text{out}}}{V_{\text{in}}}$$

$$Z = \rho v$$

$$\frac{V_{\text{out}}}{V_{\text{in}}} = - \frac{R_f}{R_i}$$

$$\frac{I_r}{I_0} = \frac{[Z_2 - Z_1]^2}{[Z_2 + Z_1]^2}$$

PERIODIC TABLE OF THE ELEMENTS

1 H 1.008 Hydrogen									2 He 4.003 Helium	
3 Li 6.941 Lithium									9 F 19.00 Fluorine	
4 Be 9.012 Beryllium									8 O 16.00 Oxygen	
11 Na 22.99 Sodium									17 Cl 35.45 Chlorine	
12 Mg 24.31 Magnesium									16 S 32.07 Sulfur	
19 K 39.10 Potassium									35 Br 79.90 Bromine	
37 Rb 85.47 Rubidium									53 I 126.9 Iodine	
55 Cs 132.9 Caesium									85 At Astatine	
87 Fr Francium									86 Rn Radon	
20 Ca 40.08 Calcium									34 Se 78.96 Selenium	
38 Sr 87.61 Strontium									52 Te 127.6 Tellurium	
56 Ba 137.3 Barium									84 Po Polonium	
88 Ra Radium									209.0 Bismuth	
21 Sc 44.96 Scandium									33 As 74.92 Arsenic	
39 Y 88.91 Yttrium									51 Sb 121.8 Antimony	
57-71 Lanthanoids									83 Bi 209.0 Bismuth	
89-103 Actinoids									84 Po Polonium	
22 Ti 47.87 Titanium									32 Ge 72.64 Germanium	
40 Zr 91.22 Zirconium									50 Sn 118.7 Tin	
72 Hf 178.5 Hafnium									82 Pb 207.2 Lead	
104 Rf Rutherfordium									112 Cn Copernicium	
23 V 50.94 Vanadium									31 Ga 69.72 Gallium	
41 Nb 92.91 Niobium									49 In 114.8 Indium	
73 Ta 180.9 Tantalum									81 Tl 204.4 Thallium	
105 Db Dubnium									111 Rg Roentgenium	
24 Cr 52.00 Chromium									29 Cu 63.55 Copper	
42 Mo 95.96 Molybdenum									47 Ag 107.9 Silver	
74 W 183.9 Tungsten									79 Au 197.0 Gold	
106 Sg Seaborgium									110 Ds Darmstadtium	
25 Mn 54.94 Manganese									27 Co 58.93 Cobalt	
43 Tc Technetium									45 Rh 102.9 Rhodium	
75 Re 186.2 Rhenium									77 Ir 192.2 Iridium	
107 Bh Bohrium									109 Mt Meitnerium	
26 Fe 55.85 Iron									28 Ni 58.69 Nickel	
44 Ru 101.1 Ruthenium									46 Pd 106.4 Palladium	
76 Os 190.2 Osmium									78 Pt 195.1 Platinum	
108 Hs Hassium									112 Cn Copernicium	
27 Co 58.93 Cobalt									29 Cu 63.55 Copper	
45 Rh 102.9 Rhodium									47 Ag 107.9 Silver	
77 Ir 192.2 Iridium									79 Au 197.0 Gold	
109 Mt Meitnerium									111 Rg Roentgenium	
28 Ni 58.69 Nickel									30 Zn 65.38 Zinc	
46 Pd 106.4 Palladium									48 Cd 112.4 Cadmium	
78 Pt 195.1 Platinum									80 Hg 200.6 Mercury	
110 Ds Darmstadtium									112 Cn Copernicium	
29 Cu 63.55 Copper									31 Ga 69.72 Gallium	
47 Ag 107.9 Silver									49 In 114.8 Indium	
79 Au 197.0 Gold									81 Tl 204.4 Thallium	
111 Rg Roentgenium									112 Cn Copernicium	

KEY

Atomic Number	79
Symbol	Au
Standard Atomic Weight	197.0
Name	Gold

Lanthanoids

57 La 138.9 Lanthanum	71 Lu 175.0 Lutetium
59 Pr 140.9 Praseodymium	69 Tm 168.9 Thulium
61 Pm Promethium	70 Yb 173.1 Ytterbium
63 Eu 152.0 Europium	71 Lu 175.0 Lutetium
65 Tb 158.9 Terbium	72 Lu 175.0 Lutetium
67 Ho 164.9 Holmium	73 Lu 175.0 Lutetium
69 Er 167.3 Erbium	74 Lu 175.0 Lutetium
71 Tm 168.9 Thulium	75 Lu 175.0 Lutetium
73 Yb 173.1 Ytterbium	76 Lu 175.0 Lutetium
75 Lu 175.0 Lutetium	77 Lu 175.0 Lutetium

Actinoids

89 Ac Actinium	103 Lr Lawrencium
91 Pa 231.0 Protactinium	101 Md Mendelevium
93 Np 237.0 Neptunium	102 No Nobelium
95 Am 243.0 Americium	103 Lr Lawrencium
97 Bk 247.0 Berkelium	104 No Nobelium
99 Es 252.0 Einsteinium	105 Nh Nihonium
101 Md 258.0 Mendelevium	106 Fl Flerovium
103 Nh 261.0 Nihonium	107 Ts Tennessine
105 Nh 261.0 Nihonium	108 Og Oganesson

Elements with atomic numbers 113 and above have been reported but not fully authenticated.

Standard atomic weights are abridged to four significant figures.

Elements with no reported values in the table have no stable nuclides.

The International Union of Pure and Applied Chemistry Periodic Table of the Elements (February 2010 version) is the principal source of data. Some data may have been modified.

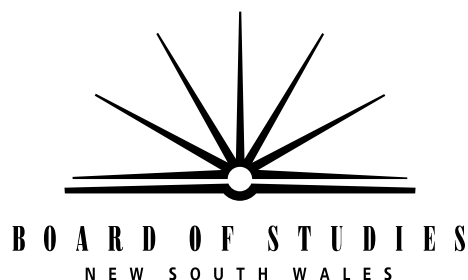

2011
HIGHER SCHOOL CERTIFICATE
EXAMINATION

--	--	--	--	--

Centre Number

--	--	--	--	--	--	--	--	--	--

Student Number

--

Question Number

Physics

Section II Answer Booklet 1

Question 31	Geophysics	Parts (a), (b) and (c)
Question 32	Medical Physics	Parts (a) and (b)
Question 33	Astrophysics	Parts (a) and (b)
Question 34	From Quanta to Quarks	Parts (a), (b) and (c)
Question 35	The Age of Silicon	Parts (a), (b), (c) and (d)

Instructions

- Answer ONE question from Questions 31–35 in this booklet and in the Section II Answer Booklet 2
- Write your Centre Number and Student Number at the top of this page
- Write the question number in the space provided

Clearly indicate which question part you are answering.

.....

.....

.....

.....

.....

.....

.....

.....

.....

.....

.....

.....

.....

.....

.....

.....

.....

.....

.....

.....

.....

.....

.....

.....

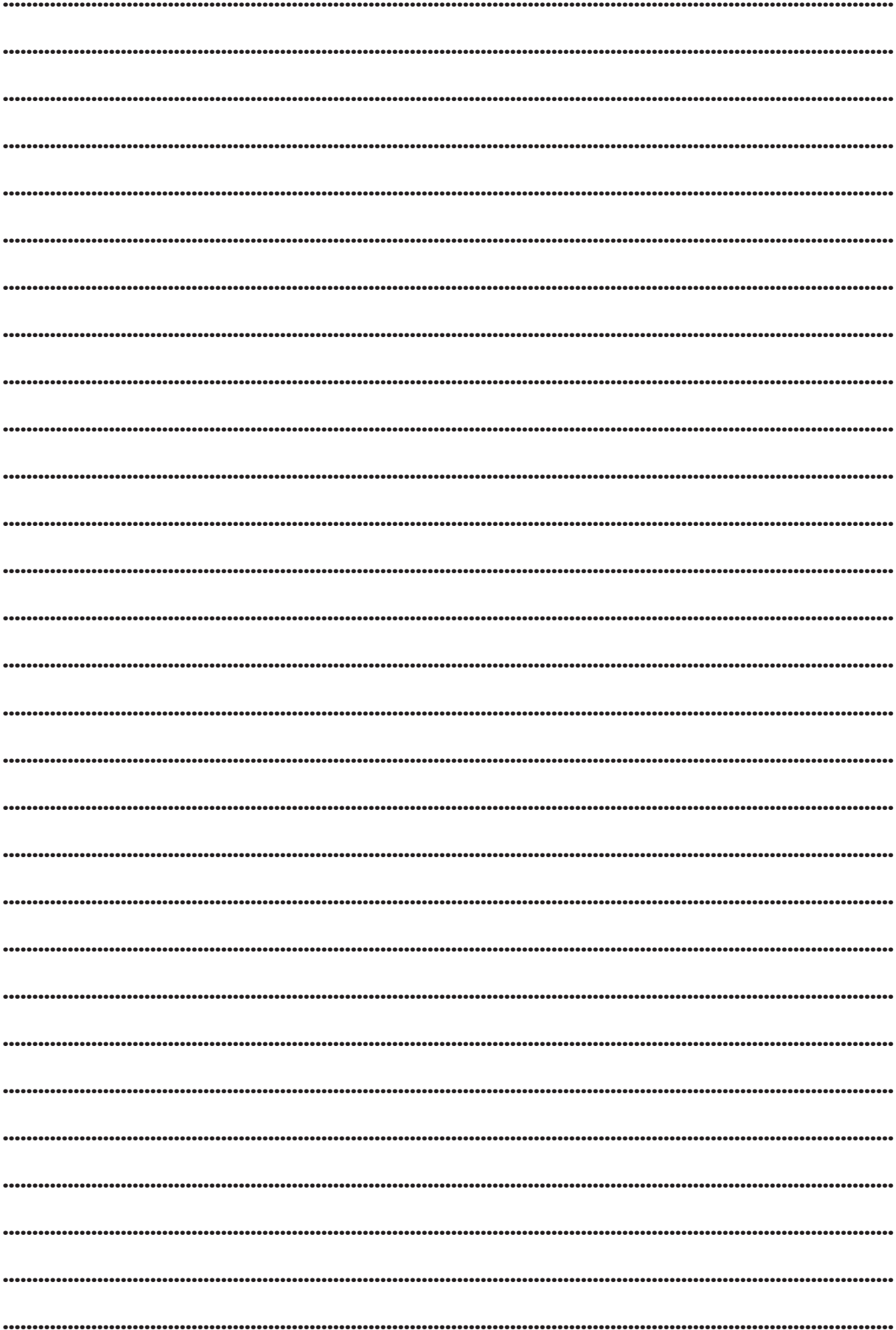

BLANK PAGE

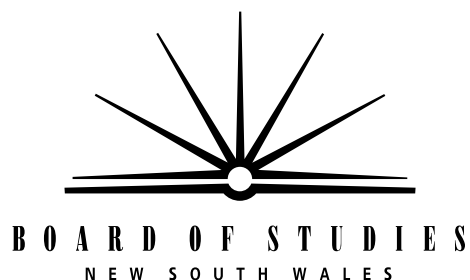

2011
HIGHER SCHOOL CERTIFICATE
EXAMINATION

--	--	--	--	--

Centre Number

--	--	--	--	--	--	--	--	--	--

Student Number

--

Question Number

Physics

Section II Answer Booklet 2

Question 31	Geophysics	Parts (d) and (e)
Question 32	Medical Physics	Parts (c), (d) and (e)
Question 33	Astrophysics	Parts (c) and (d)
Question 34	From Quanta to Quarks	Parts (d), (e), (f) and (g)
Question 35	The Age of Silicon	Parts (e), (f) and (g)

Instructions

- Answer ONE question from Questions 31–35 in this booklet and in the Section II Answer Booklet 1
- Write your Centre Number and Student Number at the top of this page
- Write the question number in the space provided

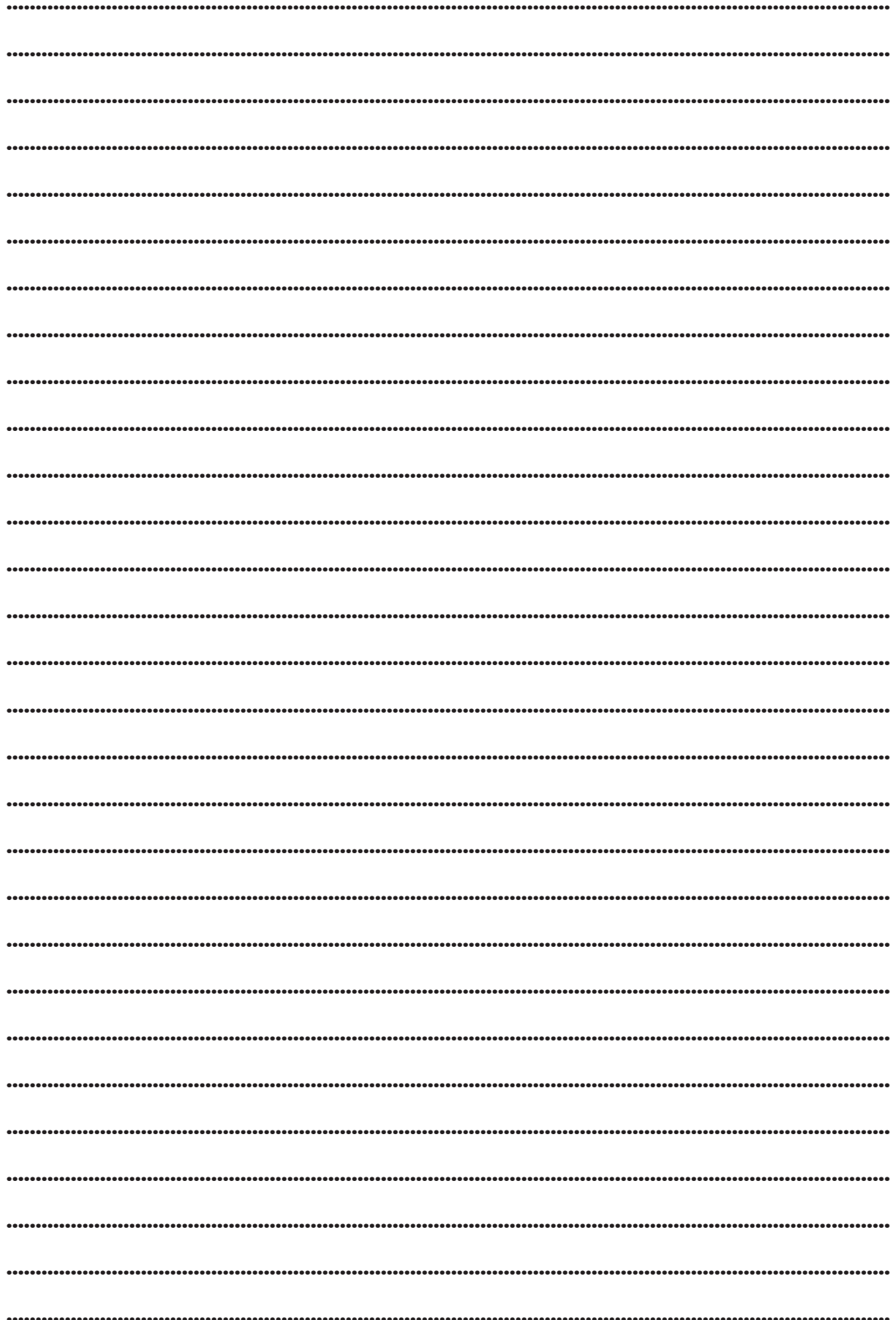

BLANK PAGE