

# Mathematics

## 2007 School Certificate Test

### General Instructions

- Reading time: 5 minutes
- Working time: 2 hours
- There will be a short break between Section 1 and Section 2
- Write using black or blue pen
- You may use a pencil to draw or complete diagrams
- Attempt ALL questions
- Calculators may be used in Section 2 only
- A formulae sheet is provided with this paper
- Write your Centre Number and Student Number at the top of pages 3 and 35

**Total marks – 100**

### Section 1

Pages 3–10

**25 marks**

Time allowed for this section is 30 minutes

Questions 1–25      25 marks

### Section 2

Pages 11–38

**75 marks**

Time allowed for this section is

1 hour and 30 minutes

This section has TWO parts

Part A – Questions 26–80      55 marks

Part B – Questions 81–84      20 marks



--	--	--	--	--

Centre Number

--	--	--	--	--	--	--	--	--

Student Number

## Section 1

**25 marks**

Time allowed for this section is 30 minutes

Answer Questions 1–25 in the spaces provided

Calculators are NOT to be used in this section

There will be a short break between Section 1 and Section 2

Answer the questions in the spaces provided.

---

1  $8 \times 0.7 =$

.....  
.....

2  $6m + 3m - m =$

.....  
.....

3 Consider the pattern:

$$6^2 = 5^2 + 2 \times 5 + 1$$

$$7^2 = 6^2 + 2 \times 6 + 1$$

$$8^2 = 7^2 + 2 \times 7 + 1$$

Using this pattern, complete

$$24^2 = \_ + \_ \times \_ + \_$$

4 Find the value of  $2l + 2b$  when  $l = 5$  and  $b = 4$ .

.....  
.....

5 The area of the shaded triangle is  $30 \text{ cm}^2$ .

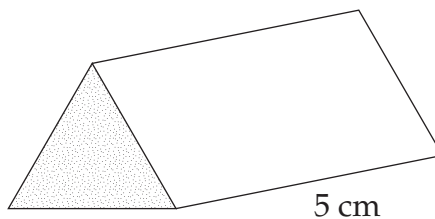

NOT TO  
SCALE

What is the volume of this triangular prism?

.....  
.....  
.....

6 Arrange the following from smallest to largest:

$$5^2, 3^2, 3^3, 2^4$$

.....  
.....

7 Calculate the area of the trapezium  $ABCD$ .

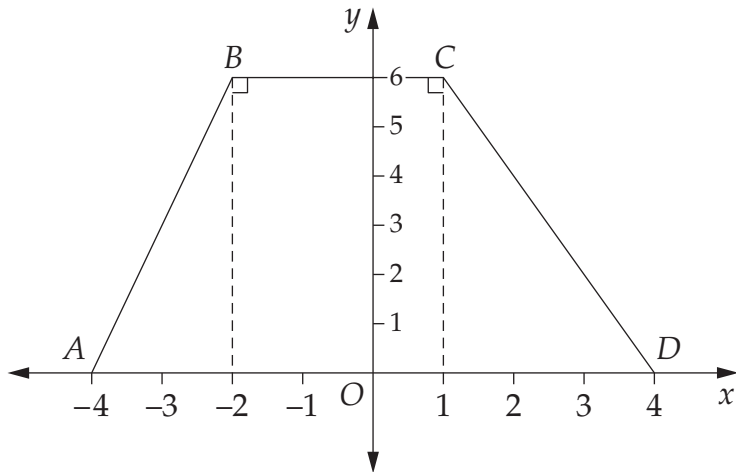

NOT TO SCALE

.....  
.....  
.....  
.....

8  $K$  is a point on the line  $y = -4x$  as shown.

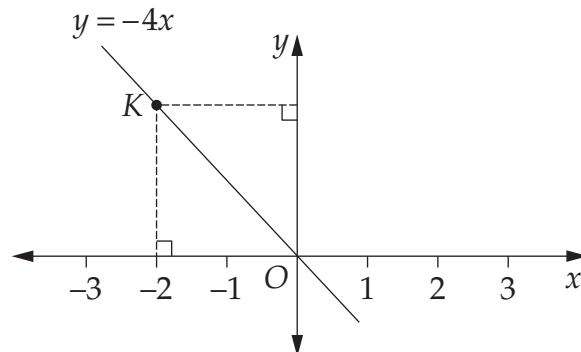

NOT TO SCALE

Complete: The coordinates of  $K$  are  $(-2, \underline{\quad})$ .

9 Solve  $\frac{n}{3} < -2$ .

.....  
.....

10  $800 \div 32 = 25$

Write a number in the box so that the statement below is correct.

$800 \div \square = 50$

11 The diagram shows two triangles.

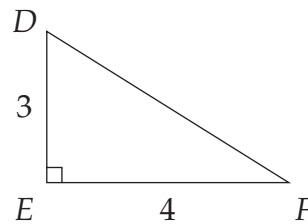
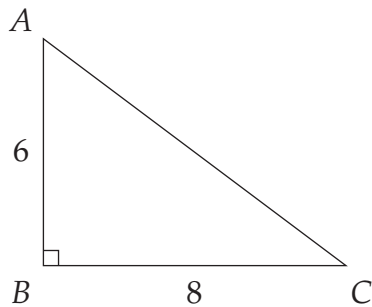

NOT TO  
SCALE

Explain why  $\angle ACB = \angle DFE$ .

.....

12 There are 12 dots equally spaced around a circle.

Join four dots on the circle to make a square.

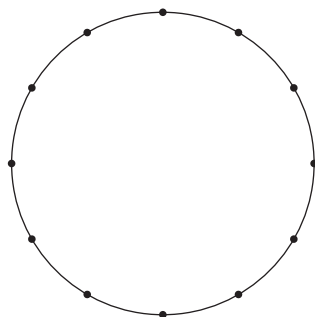

- 13 A fishing boat drops a crab pot every 10 minutes.

How many hours does it take to drop 96 crab pots?

.....

.....

.....

- 14 On the dot paper draw a rectangle that has an area equal to the area of the triangle.

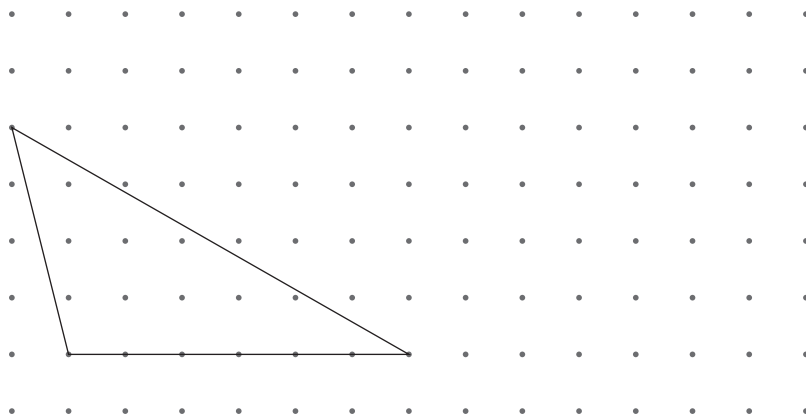

- 15 In the triangle, it is given that  $\tan \theta = \frac{2}{3}$ .

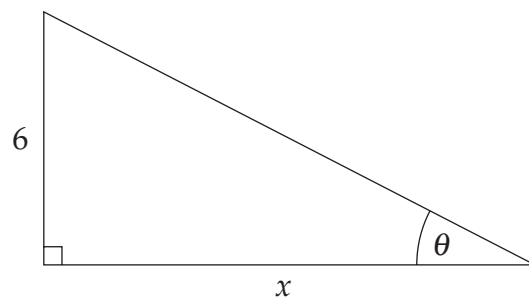

NOT TO SCALE

What is the value of  $x$ ?

.....

16 Sam multiplies two whole numbers together, and gets an answer of 231.

Neither of the numbers is 1.

What could the two numbers be?

.....  
.....

17  $O$  is the centre of the circle.

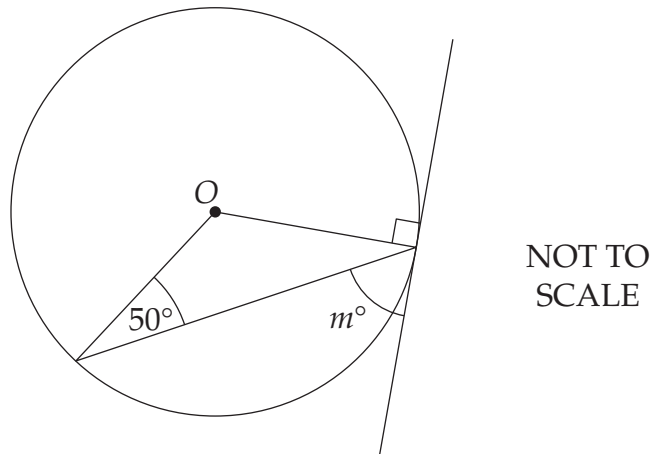

What is the value of  $m$ ?

.....  
.....

18 Calculate  $(3 \times 10^4) \times (2 \times 10^{-6})$ , expressing your answer in scientific notation.

.....  
.....  
.....

19 Joshua is using three different points to graph the curve  $y = x^2 + 3$ .

What is the missing value in Joshua's table?

$x$	-2	0	
$y$	7	3	7

Use the following information to answer Questions 20 and 21.

A bag contains 12 marbles. The marbles are either black or green. When one marble is chosen at random from the bag, the probability that it is black is  $\frac{1}{4}$ .

20 On the diagram, colour in circles to show how many marbles are black.

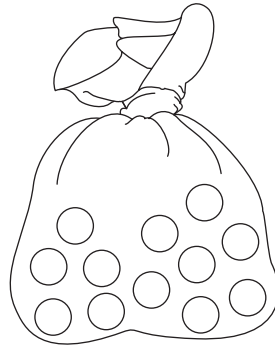

21 Some red marbles are added to the bag so that the probability of choosing a red marble will be  $\frac{1}{3}$ .

How many red marbles are added to the bag?

.....  
.....

22 Complete:  $2p(\dots\dots\dots) = 6p^2 - 2p$

23 Solve the equation:  $3(m + 8) = -6$

.....  
.....  
.....  
.....

- 24 In the diagram,  $KLM$  is an equilateral triangle and  $KM = KN$ .

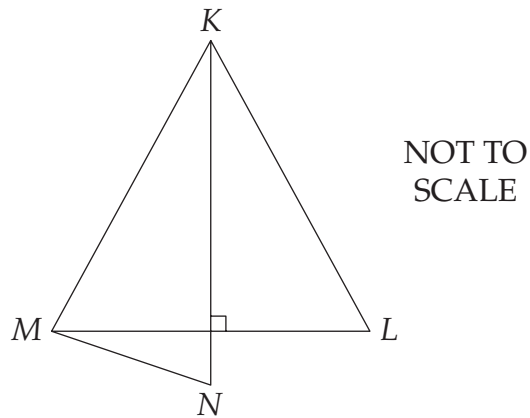

Find the size of  $\angle KMN$ .

.....  
.....

- 25 The school yard,  $ABCD$ , is a square 400 m by 400 m.

Leah is standing somewhere in the school yard. She is more than 350 m from both corner  $A$  and corner  $B$ .

Using the given scale and your geometrical instruments, shade the region where Leah could be standing.

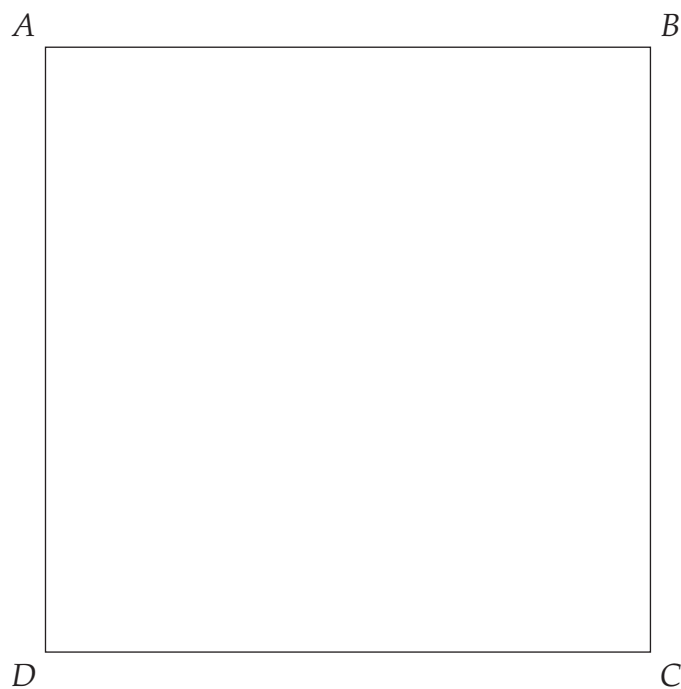

Scale  
2 cm = 100 m

**End of Section 1**

## Section 2

**75 marks**

Time allowed for this section is  
1 hour and 30 minutes

This section has TWO parts

Part A – Questions 26–80     55 marks

Part B – Questions 81–84     20 marks

Calculators may be used in this section

Do not commence Section 2 until you are  
instructed to do so



26 Which of the following is the top view of a triangular pyramid?

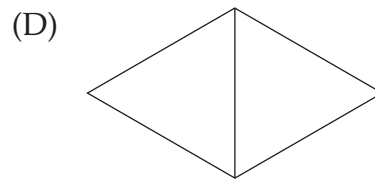
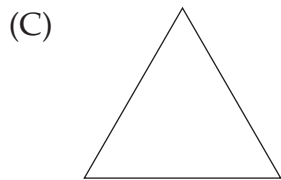
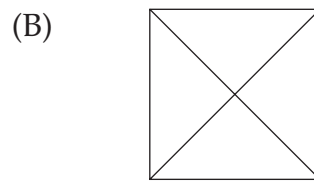
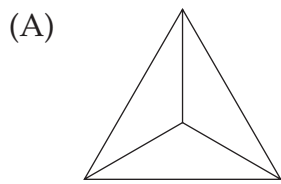

27 What is the area of this parallelogram?

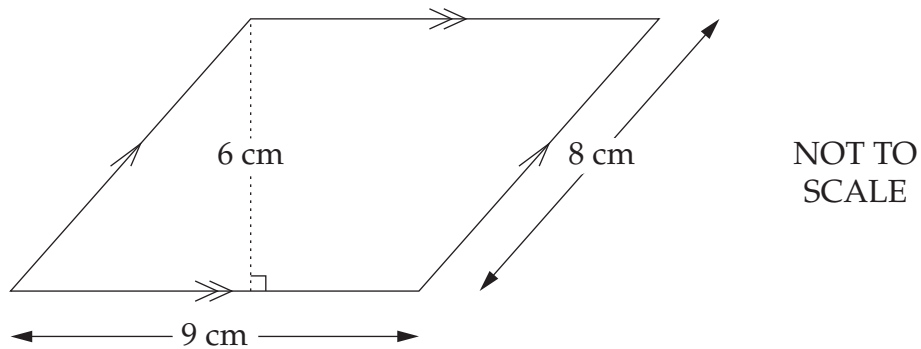

- (A)  $27 \text{ cm}^2$       (B)  $36 \text{ cm}^2$       (C)  $54 \text{ cm}^2$       (D)  $72 \text{ cm}^2$

28 A number of matches,  $M$ , is used to make a certain number of squares,  $S$ .

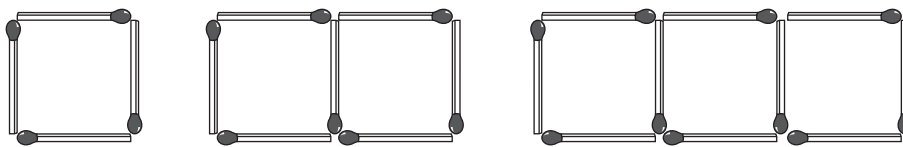

Which rule describes the pattern shown?

- (A)  $M = 3S$   
 (B)  $M = 4S$   
 (C)  $M = 3S + 1$   
 (D)  $M = 4S - 1$

29 The plateosaurus was a dinosaur that lived about 220 million years ago.

What is this number in scientific notation?

- (A)  $2.2 \times 10^6$       (B)  $2.2 \times 10^7$       (C)  $2.2 \times 10^8$       (D)  $2.2 \times 10^9$
- 

30 Which of the following graphs represents  $x > -2$ ?

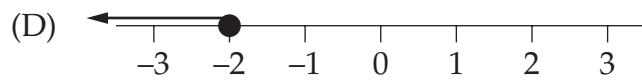
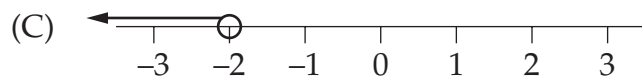
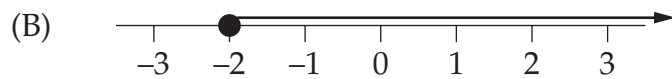
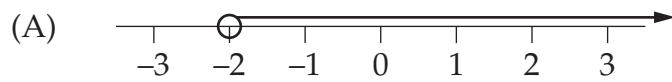

31  $6\frac{1}{2}\%$  =

- (A) 0.0065      (B) 0.065      (C) 0.65      (D) 6.5
- 

32  $15a^8 \div 5a^2 =$

- (A)  $3a^4$       (B)  $3a^6$       (C)  $10a^4$       (D)  $10a^6$
-

- 33 Luis starts his journey 5 km from his home and travels to Bella's place. Bella's place is 10 km from Luis' home. Luis then returns to his home.

Which graph best represents Luis' journey?

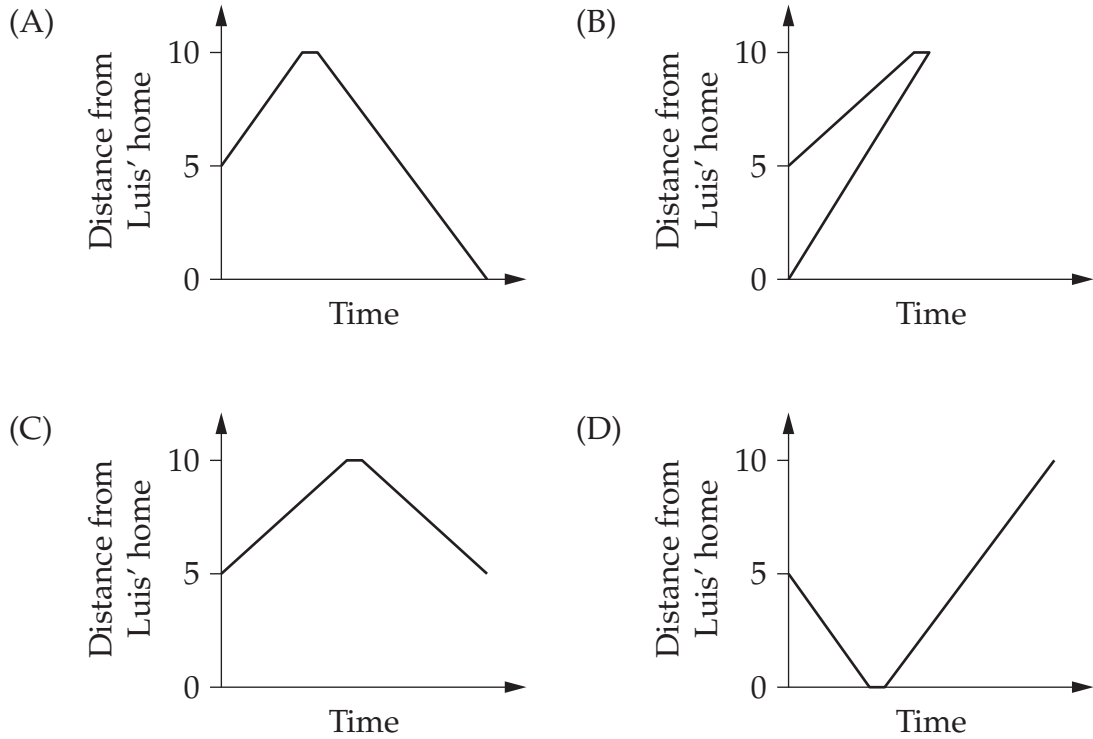

- 34 What is the equation of the  $y$ -axis?

- (A)  $x = 0$       (B)  $y = 0$       (C)  $y = x$       (D)  $x + y = 0$

- 35 Amy correctly calculated the size of angle  $\theta$  using trigonometry.

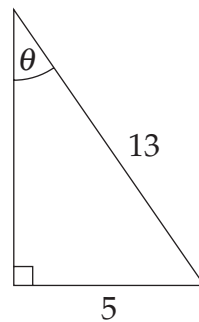

NOT TO SCALE

What was her first line of working?

- (A)  $\sin \theta = \frac{5}{13}$       (B)  $\sin \theta = \frac{13}{5}$       (C)  $\cos \theta = \frac{5}{13}$       (D)  $\cos \theta = \frac{13}{5}$

- 36 What scale factor would enlarge Circle A to Circle B?

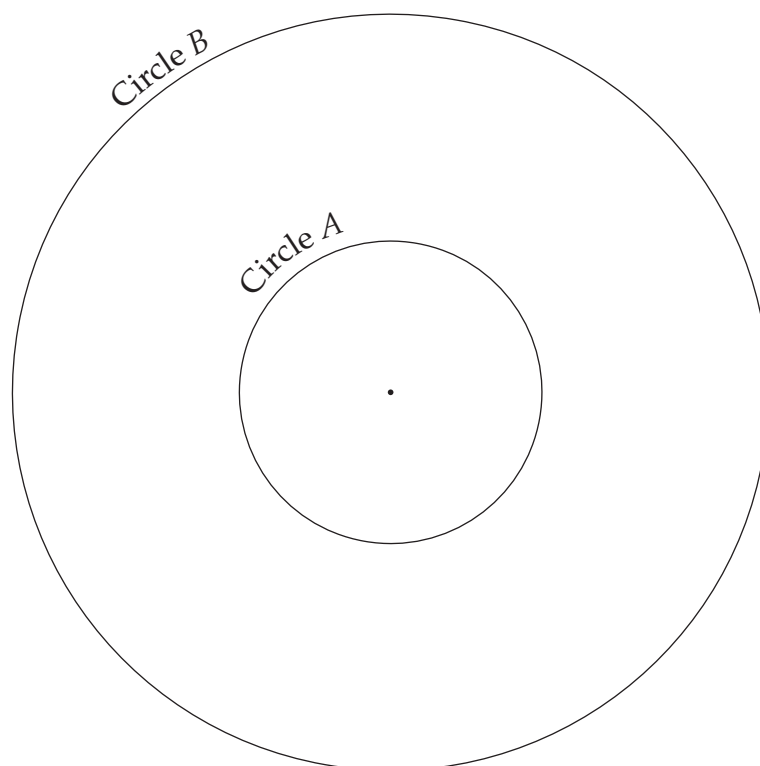

- (A)  $\frac{2}{5}$       (B)  $\frac{5}{2}$       (C) 3      (D) 5
- 

- 37 What is the surface area of this triangular prism?

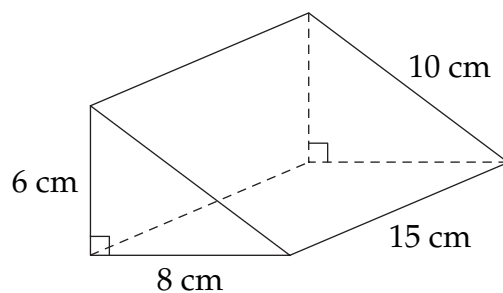

NOT TO  
SCALE

- (A)  $318 \text{ cm}^2$       (B)  $360 \text{ cm}^2$       (C)  $384 \text{ cm}^2$       (D)  $408 \text{ cm}^2$
-

38 What is the value of  $\frac{2.4 + 3.6}{11.5 + 2.1}$ , correct to two decimal places?

- (A) 0.44                      (B) 2.62                      (C) 2.66                      (D) 4.81
- 

39 At the school canteen, nine children were asked to answer the question “What is your favourite fruit drink?”.

The results are shown in the table.

Pineapple	1
Apple	3
Orange	5

Is it possible to find the median of the data?

- (A) No. Reason: categorical data.  
(B) No. Reason: insufficient data.  
(C) Yes. Reason: ordered data.  
(D) Yes. Reason: numerical data.
- 

40 There are 12 students in a class. The stem-and-leaf plot shows the number of hours the students spend on homework each week.

0		3 7 7 9 9
1		0 1 1 1 4
2		8 9

What is the mean number of hours spent on homework each week, correct to one decimal place?

- (A) 4.9                      (B) 10.5                      (C) 11.0                      (D) 12.4
-

- 41 Dominic downloads a 1.8 megabyte song at 0.003 megabytes per second. Eva downloads the same song at 0.002 megabytes per second.

How much longer, in seconds, will Eva take to download the song?

- (A) 300                      (B) 360                      (C) 600                      (D) 1800
- 

- 42 What is the gradient of the line drawn?

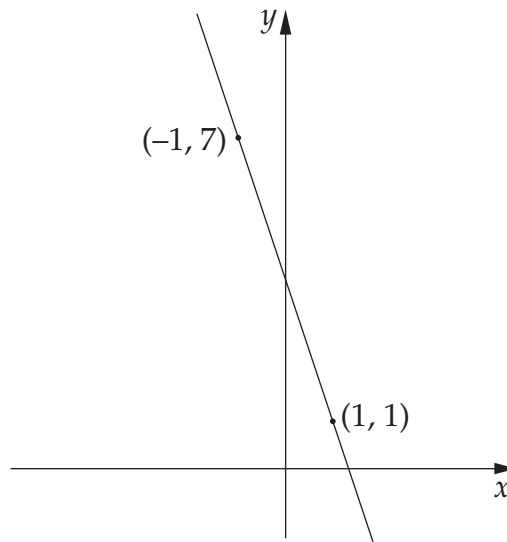

- (A)  $-3$                       (B)  $-\frac{1}{3}$                       (C)  $\frac{1}{3}$                       (D)  $3$
- 

- 43  $6x^0 + 7 =$

- (A) 7                      (B) 8                      (C) 13                      (D) 14
- 

- 44  $\frac{1}{3} + \frac{x}{6} =$

- (A)  $\frac{1+x}{6}$                       (B)  $\frac{2+x}{6}$                       (C)  $\frac{1+x}{9}$                       (D)  $\frac{6+x}{18}$
-

- 45 It is estimated that a person ingests 4.5 L of pesticides and herbicides per year.  
How many millilitres per day does this represent?
- (A) 0.0123      (B) 0.123      (C) 1.23      (D) 12.3
- 

- 46 Sarah received her water and sewerage account.

<b>Supply charges</b>	
Sewerage supply charge	\$18.75
Water supply charge	\$97.25
<b>Water consumption charges</b>	
18 kL × \$0.5800 per kL	\$ _____
21 kL × \$1.1350 per kL	\$ _____

How much is Sarah charged in total?

- (A) \$81.73      (B) \$116.00      (C) \$117.72      (D) \$150.28
- 
- 47 Brisbane is 10 hours ahead of London and New York is 5 hours behind London. Oliver lives in Brisbane. At 12 noon on 5 November, Oliver calls Lily who lives in New York.
- What time and date is it in New York?
- (A) 9 pm on 4 November  
(B) 7 am on 5 November  
(C) 5 pm on 5 November  
(D) 3 am on 6 November
-

- 48 A square of side length 8 cm is cut along the dotted line to form two right-angled triangles.

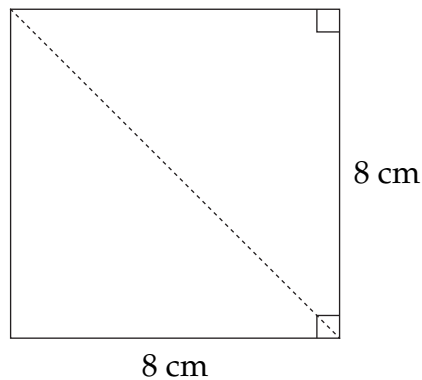

What is the perimeter, to the nearest centimetre, of one of the right-angled triangles formed?

- (A) 24 cm      (B) 27 cm      (C) 32 cm      (D) 43 cm
- 

- 49 How many square millimetres are there in 20 square centimetres?

- (A) 2      (B) 200      (C) 2000      (D) 20 000
- 

- 50 The following call charges apply for mobile phone video calls:

Call rate (per 30 seconds)	45 cents
Flagfall per call (charged once per call)	35 cents

What is the cost of a 12-minute call?

- (A) \$5.75      (B) \$9.60      (C) \$11.15      (D) \$13.85
- 

- 51 The area of a circle is  $100\pi$  square metres.

What is the diameter of this circle?

- (A) 6 m      (B) 10 m      (C) 20 m      (D) 50 m
-

- 52 The ages of visitors to a park were recorded. The results are shown below.

<i>Age</i>	<i>Frequency</i>
15–29	470
30–44	165
45–59	93
Total	728

What calculation would be used to work out the mean age?

- (A)  $\frac{15 \times 470 + 30 \times 165 + 45 \times 93}{728}$
- (B)  $\frac{22 \times 470 + 37 \times 165 + 52 \times 93}{728}$
- (C)  $\frac{29 \times 470 + 44 \times 165 + 59 \times 93}{728}$
- (D)  $\frac{44 \times 470 + 74 \times 165 + 104 \times 93}{728}$
- 

- 53 Dick invests \$1000 in a share plan. It makes 20% in the first year but loses 20% in the second year.

How much is Dick's investment worth after two years?

- (A) \$640            (B) \$960            (C) \$1000            (D) \$1440
- 

- 54 Find the solution of the equation  $\frac{5x - 4}{2} = 10$ .

- (A)  $x = 1\frac{4}{5}$             (B)  $x = 2\frac{2}{5}$             (C)  $x = 4\frac{4}{5}$             (D)  $x = 5\frac{3}{5}$
-

- 55 The reciprocal of  $a$  is  $\frac{1}{a}$ .

What is the reciprocal of  $4^{-2}$ ?

- (A)  $\frac{1}{16}$                       (B)  $\frac{1}{8}$                       (C) 8                      (D) 16
- 

- 56 Gemma stacks four blocks, each a different colour, on top of one another to create a 'tower'.

How many different 'towers' can she make if she puts all four blocks in a different order each time?

- (A) 1                      (B) 4                      (C) 10                      (D) 24
- 

- 57 This box has a volume of  $16 \text{ cm}^3$  and the top is a square of side length 4 cm.

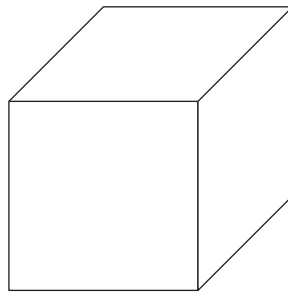

NOT TO  
SCALE

What is the height of the box?

- (A)  $\frac{1}{4}$  cm                      (B) 1 cm                      (C) 2 cm                      (D) 4 cm
-

58

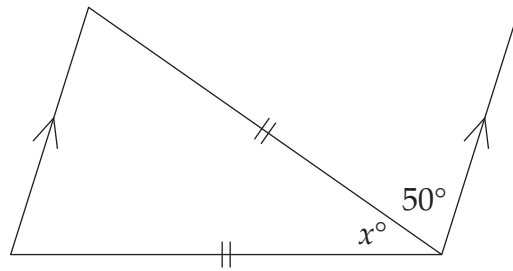

NOT TO  
SCALE

What is the value of  $x$ ?

- (A) 40                      (B) 50                      (C) 65                      (D) 80
- 

59 Colin sold a DVD player for \$180. This was \$60 less than Colin originally paid for it.

What was Colin's loss as a percentage of his cost price?

- (A) 25%                      (B)  $33\frac{1}{3}\%$                       (C) 50%                      (D) 75%
- 

60 A piece of timber is in the shape of a cube. Allan cuts the timber along the shaded plane to form two solids.

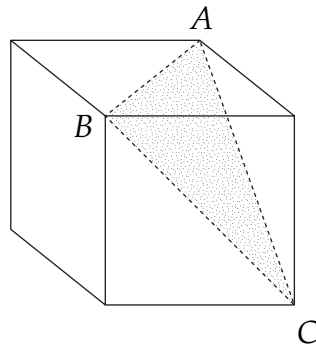

What is the size of  $\angle ABC$ ?

- (A)  $30^\circ$                       (B)  $45^\circ$                       (C)  $60^\circ$                       (D)  $90^\circ$
-

- 61 The following table is used to calculate the value, to the nearest dollar, of an investment of \$1000, at different compound interest rates.

Interest rate (per annum) \ Number of years	2	4	6	8
2%	1040	1082	1126	1172
4%	1082	1170	1265	1369
6%	1124	1262	1419	1594
8%	1166	1360	1587	1851

\$6000 is invested at 4% per annum, compounded yearly.

What is the value of the investment after 8 years?

- (A) \$1360      (B) \$1369      (C) \$8160      (D) \$8214
- 

- 62 Students were asked to arrange the same three recurring decimals from smallest to largest.

Which arrangement is correct?

- (A)  $0.\dot{5}$ ,  $0.5\dot{2}$ ,  $0.52\dot{8}$   
(B)  $0.5\dot{2}$ ,  $0.52\dot{8}$ ,  $0.\dot{5}$   
(C)  $0.52\dot{8}$ ,  $0.\dot{5}$ ,  $0.5\dot{2}$   
(D)  $0.52\dot{8}$ ,  $0.5\dot{2}$ ,  $0.\dot{5}$
-

- 63 A standard deck of cards contains 52 cards, including four queens. I select a card at random from a standard deck.

What is the probability that I do NOT select a queen?

- (A)  $\frac{1}{52}$                       (B)  $\frac{1}{13}$                       (C)  $\frac{12}{13}$                       (D)  $\frac{51}{52}$
- 

- 64 The values on opposite faces of a die add up to seven.

Which of the following nets represents this die?

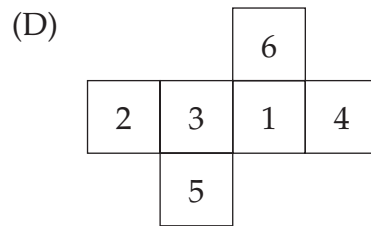
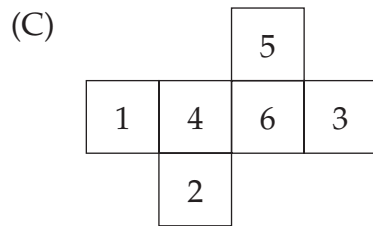
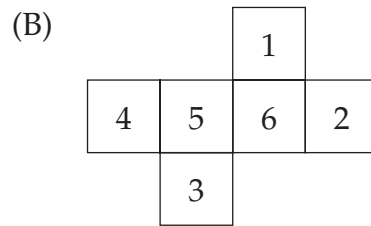
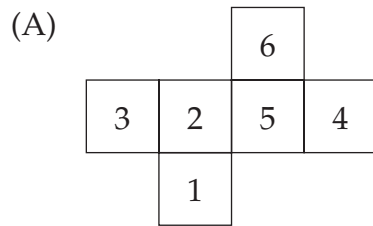

- 65 The diagram shows a composite shape made up of a square and a quadrant.

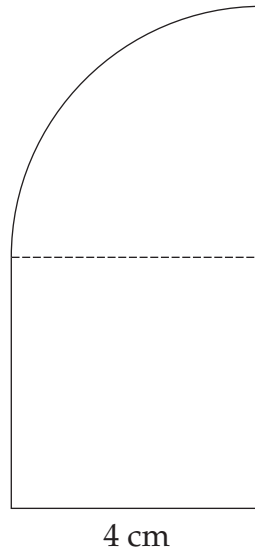

What is the perimeter of the shape, correct to one decimal place?

- (A) 18.3 cm      (B) 22.3 cm      (C) 26.3 cm      (D) 28.6 cm
- 

- 66 A frequency distribution table is shown.

<i>Score</i>	<i>Frequency</i>	<i>Relative frequency</i>
2	5	0.25
3	<input type="text"/>	0.3
4	9	0.45

What is the value of  ?

- (A) 1      (B) 6      (C) 7      (D) 10
-

- 67 The diagram shows a kite.

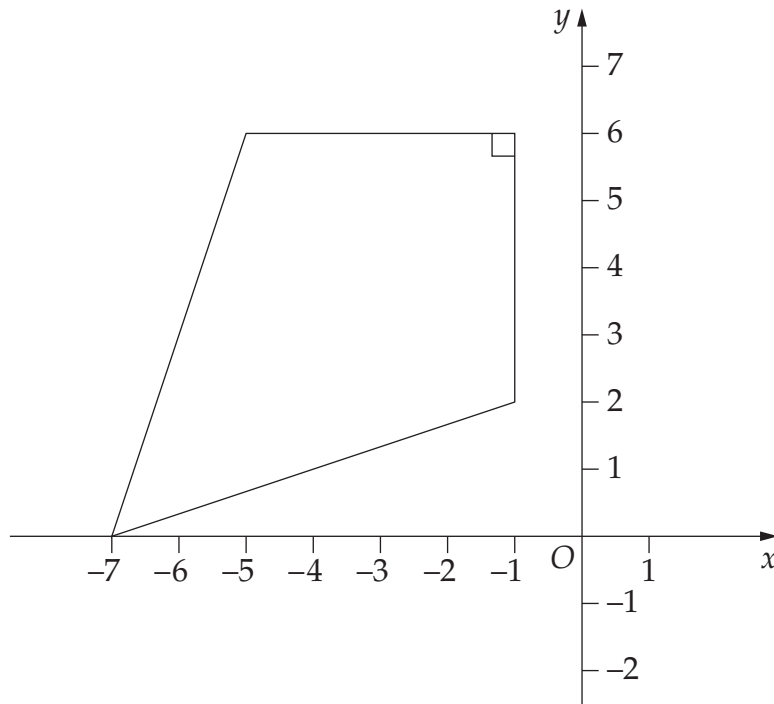

Which of the following is the point of intersection of the diagonals of the kite?

- (A)  $(4, -3)$       (B)  $(-3, 4)$       (C)  $(4, 3)$       (D)  $(-3, 3)$
- 

- 68 Erica earns \$6 per hour. Robert earns \$8 per hour. Last week they both earned the same amount of money, which was more than \$100.

What is the least number of hours that Erica could have worked last week?

- (A) 15      (B) 18      (C) 20      (D) 24
- 

- 69

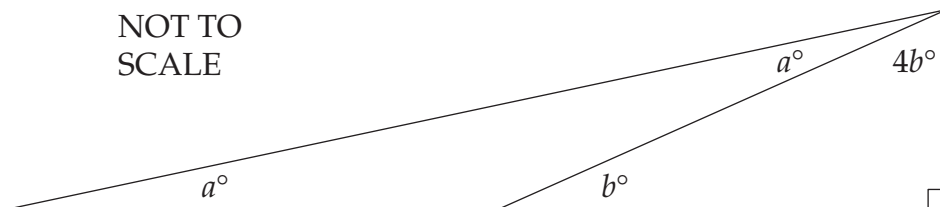

What is the value of  $a$ ?

- (A) 9      (B) 10      (C) 12      (D) 15
-

70 Maggie has  $y$  lollies.

Lisa has three more lollies than Maggie.

Bart has twice as many lollies as Lisa.

How many lollies do Maggie, Lisa and Bart have altogether?

- (A)  $y + 9$       (B)  $4y + 3$       (C)  $4y + 6$       (D)  $4y + 9$
- 

71 Donna is paid an hourly rate based on a 38-hour week and receives time-and-a-half for any hours worked overtime. Last week she worked 44 hours and was paid \$2219.34.

What is Donna's normal hourly rate?

- (A) \$47.22      (B) \$50.44      (C) \$54.13      (D) \$58.40
- 

72 Given  $a:b = 2:3$   
and  $b:c = 4:5$ ,  
what is  $a:c$ ?

- (A) 1:2      (B) 2:5      (C) 3:5      (D) 8:15
- 

73 A tower's observation deck is 400 m above the ground. Erin ( $E$ ) is standing at one end of the observation deck and her father ( $F$ ) is standing on the ground, 200 m from the base of the tower.

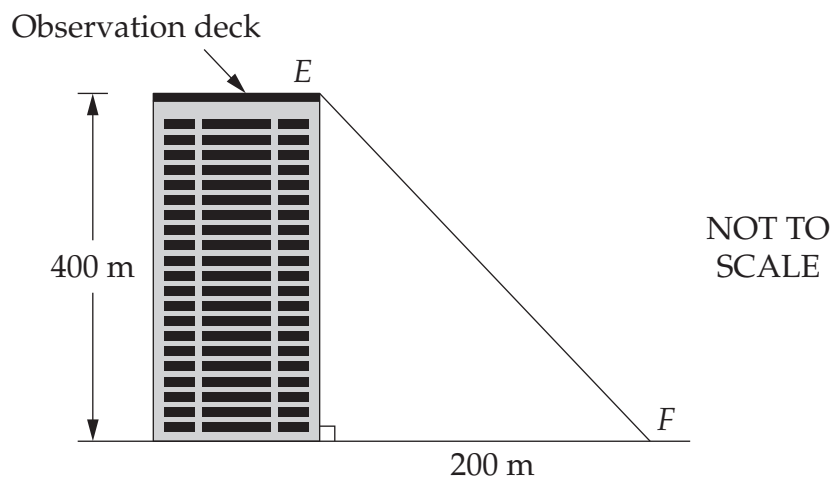

What is the angle of depression from Erin to her father?

- (A)  $27^\circ$       (B)  $30^\circ$       (C)  $60^\circ$       (D)  $63^\circ$
-

- 74 The shaded region has been obtained by removing two semicircles of radius 4 cm from a rectangle.

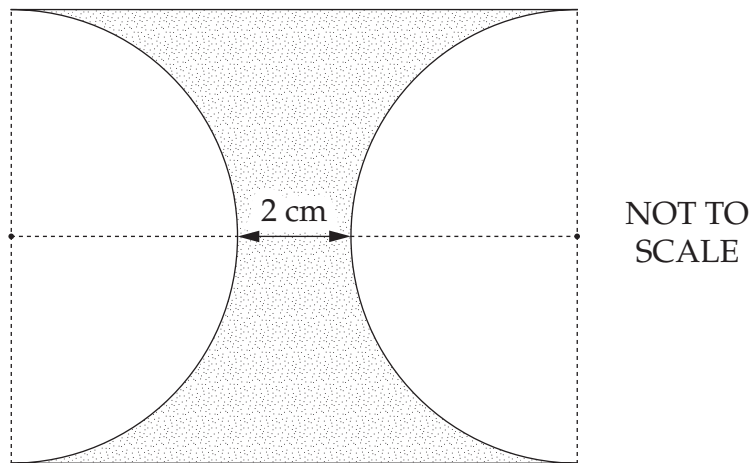

What is the area of the shaded region, correct to two decimal places?

- (A)  $11.43 \text{ cm}^2$     (B)  $29.73 \text{ cm}^2$     (C)  $45.13 \text{ cm}^2$     (D)  $54.87 \text{ cm}^2$
- 
- 75 Catherine designed this pattern for a patchwork quilt. The pattern consists of five congruent kites, as shown.

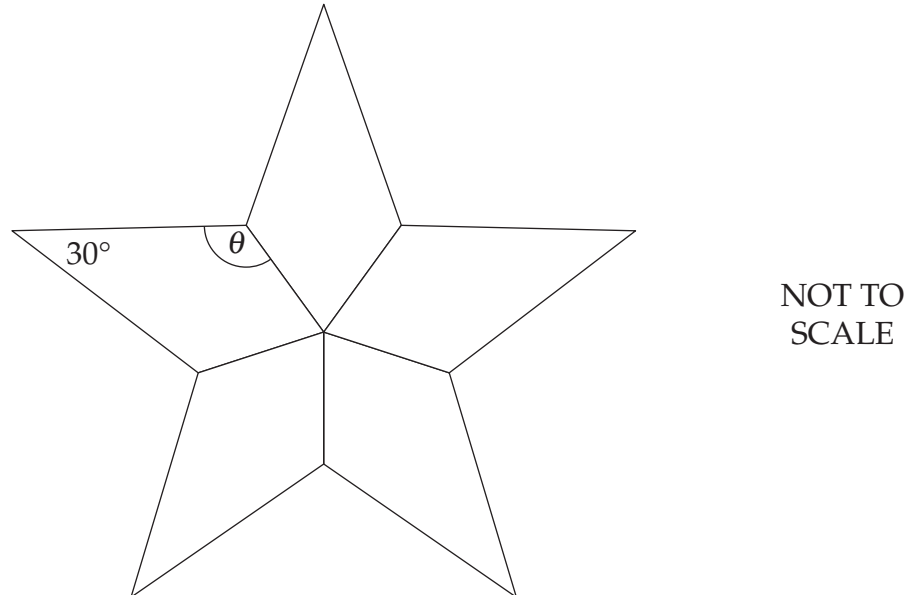

What is the size of  $\theta$ ?

- (A)  $39^\circ$     (B)  $129^\circ$     (C)  $135^\circ$     (D)  $150^\circ$
-

## Section 2 (continued)

---

### Instructions for answering Questions 76–80

- Questions 76–80 contain options a, b, c and d. Each option may be Correct or Incorrect. In each question, one, two, three or four options may be Correct.
- For Questions 76–80, fill in the response ovals on the Section 2 – Part A Answer Sheet to indicate whether options a, b, c and d are Correct or Incorrect. You must fill in either the Correct or the Incorrect response oval for each option.

		Correct	Incorrect
<b>Sample:</b>	a. $2 + 4 = 4 + 2$	<input checked="" type="radio"/>	<input type="radio"/>
	b. $2 - 4 = 4 - 2$	<input type="radio"/>	<input checked="" type="radio"/>
	c. $2 \times 4 = 4 \times 2$	<input checked="" type="radio"/>	<input type="radio"/>
	d. $2 \div 4 = 4 \div 2$	<input type="radio"/>	<input checked="" type="radio"/>

- If you think you have made a mistake, put a cross through your answer and fill in your new answer.

	Correct	Incorrect
a.	<input checked="" type="radio"/>	<input checked="" type="radio"/>

- If you change your mind and have crossed out what you consider to be the right answer, then indicate your intended answer by writing the word 'answer' and drawing an arrow as follows.

	Correct	Incorrect
a.	<input checked="" type="radio"/>	<input checked="" type="radio"/>

*answer*  
↙

76 The diagram shows a rhombus  $ABCD$ .

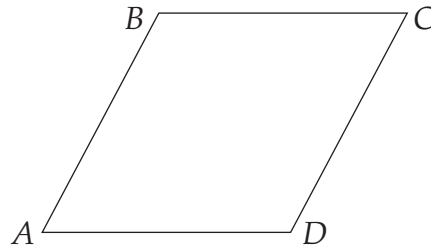

Indicate whether each of the following is Correct or Incorrect.

- a.  $AC \perp BD$
- b.  $AC = BD$
- c.  $AC$  bisects  $BD$ .
- d.  $AC$  is an axis of symmetry.

77 Elke was asked to write the equations of graphs which pass through the point  $(4, 3)$ . The four equations that she wrote are listed below.

Indicate whether each of the following is Correct or Incorrect.

- a.  $y = x + 1$
- b.  $y = 7 - x$
- c.  $y = \frac{x}{2} + 1$
- d.  $2x + y = 9$

78 Cooper is given an unmarked diagram. He is asked to mark the diagram to indicate properties that will ensure the diagram is always a rectangle.

Indicate whether each of the following is Correct or Incorrect.

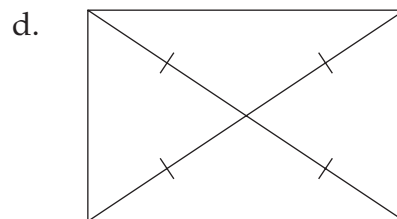
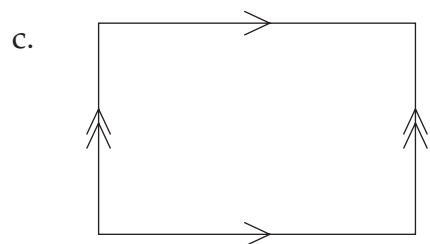
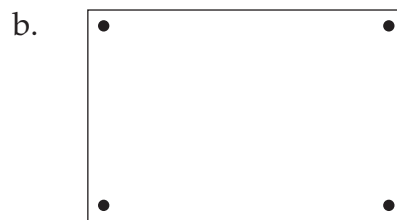
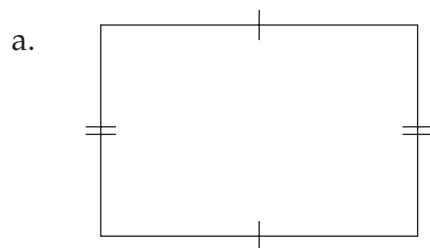

NOT TO SCALE

- 79 Lucy was asked to write an expression for the area of  $PQRS$ .

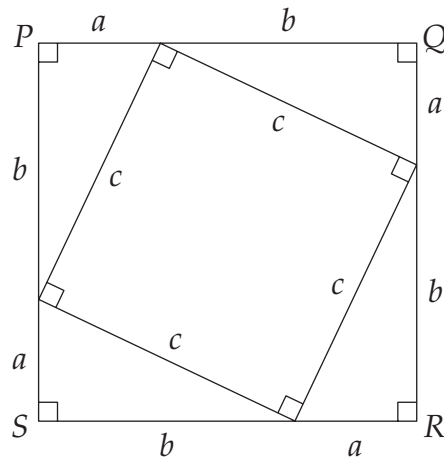

Indicate whether each of the following is Correct or Incorrect.

- (A)  $(a + b)^2$       (B)  $a^2 + b^2$       (C)  $2ab + c^2$       (D)  $4ab + c^2$
- 

- 80 Michelle, Heba, Robyn and Sharon are comparing their wages.

Heba earns \$700 per week. Robyn earns \$2600 per month. Sharon earns \$35 000 per year. Michelle does not earn the largest wage.

Their names are written to show their yearly salaries in order from smallest to largest.

Indicate whether each of the following could be Correct or Incorrect.

- Heba, Robyn, Michelle, Sharon
  - Robyn, Sharon, Michelle, Heba
  - Michelle, Robyn, Sharon, Heba
  - Sharon, Robyn, Michelle, Heba
-

BLANK PAGE

BLANK PAGE

--	--	--	--	--

Centre Number

**Section 2 (continued)**

--	--	--	--	--	--	--	--	--

Student Number

**Part B**

Questions 81–84      20 marks

Answer the questions in the spaces provided.

---

**Marks**

**Question 81** (5 marks)

Stella is a netball player. The number of goals she scored in her first seven games was 3, 4, 5, 5, 6, 8, 9.

- (a) Explain why the mode is 5. **1**

.....  
.....

- (b) Based on these figures, what is the probability that in a particular future game, Stella will score at least six goals? **1**

.....  
.....

- (c) Calculate the mean number of goals. **1**

.....  
.....  
.....

- (d) Stella's coach claims that it is possible for Stella to achieve a median of 7 and a range of 7 after three more matches are completed. **2**

Give a possible set of scores for the next three matches that would allow Stella to achieve this.

.....  
.....  
.....  
.....

**Question 82** (5 marks)

Eleni has always bought her petrol from Pete’s service station. Pete’s service station is next door to Eleni’s house and sells petrol at \$1.24/litre.

- (a) Eleni purchases 60 litres of petrol from Pete’s station. 1

How much does this cost?

.....  
.....

- (b) Jim’s service station charges \$1.16/litre for petrol. 1

What is the percentage saving per litre of petrol compared to Pete’s service station?

.....  
.....

- (c) Eleni’s car uses 15 litres of petrol per 100 km. 1

How much petrol does the car use to travel 20 km?

.....  
.....

- (d) Jim’s service station is 20 km from Eleni’s house. Eleni decides to make a return trip to Jim’s service station to buy the cheaper petrol. She purchases 60 litres of petrol. 2

Explain, with mathematical calculations, whether Eleni loses or saves money making this return trip to Jim’s service station.

.....  
.....  
.....  
.....

**Question 83** (5 marks)

Brad bought a car priced at \$20 000 on terms. He paid a 12% deposit.

- (a) Calculate the deposit paid. **1**

.....  
.....

- (b) Simple interest was charged on the balance at 7% per annum over four years. **2**

Calculate the total interest that he was charged.

.....  
.....  
.....  
.....

- (c) What is the total amount that Brad paid for the car? **1**

.....  
.....

- (d) Brad paid the balance plus interest in equal monthly instalments over four years. **1**

How much did he pay each month?

.....  
.....  
.....  
.....

**Please turn over**

**Question 84** (5 marks)

The diagram shows the metal frame of a roof. The triangle  $ABC$  is isosceles with  $AB = CB$ . The midpoints of  $AB$  and  $CB$  are  $Y$  and  $Z$  respectively.

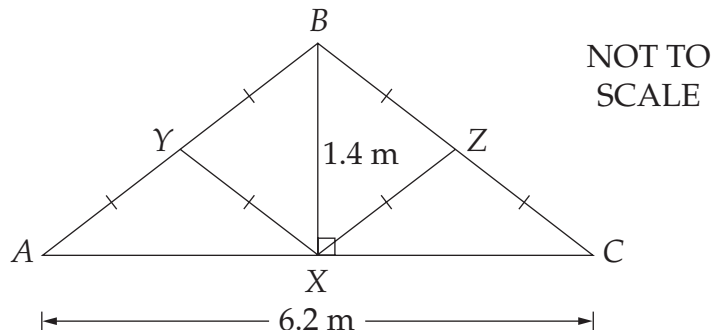

- (a) Show, by calculation, that the length of  $AB$  is 3.4 metres, correct to one decimal place. 2

.....

.....

.....

.....

- (b) Find the total length of metal required to make this frame. 1

.....

.....

- (c) Use trigonometry to find  $\angle BAX$ . Give your answer to the nearest degree. 1

.....

.....

- (d) Find  $\angle BYX$ . 1

.....

.....

**End of test**