



BOARD OF STUDIES
NEW SOUTH WALES

**1999
SCHOOL
CERTIFICATE
TEST**

9 November

MATHEMATICS

**SECTION 2
Part A**

CENTRE NUMBER

--	--	--	--	--

STUDENT NUMBER

--	--	--	--	--	--	--	--

Directions for Section 2—Part A

- 1 You have 90 minutes to answer Section 2 Part A and Part B
- 2 • Part A Questions 26–75 (50 marks)
 - Allow about 60 minutes to answer this part
- 3 Calculators may be used in this part
- 4 • Complete your answers to Questions 26–50 on Section 2—Part A—Answer Sheet 3
 - Complete your answers to Questions 51–69 on Section 2—Part A—Answer Sheet 4
 - Complete your answers to Questions 70–75 in this booklet
- 5 Write your Centre Number and Student Number at the top of this page

BLANK PAGE

Complete your answers to Questions 26–50 on the Section 2—Part A—Answer Sheet 3.

26 Which of the following is a net of a triangular pyramid?

(A)

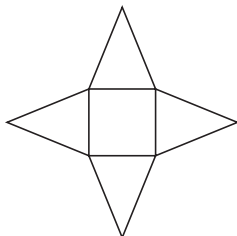

(B)

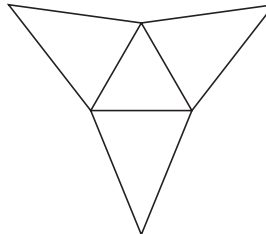

(C)

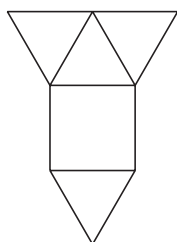

(D)

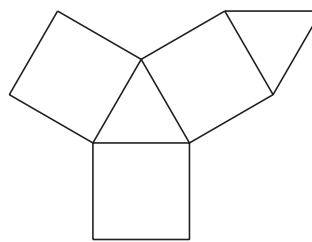

27 A group of Year 10 students draw a one-metre square on the ground.

Estimate the greatest number of students of average size that can stand in the square with both feet on the ground.

(A) 5

(B) 16

(C) 30

(D) 36

28 Anike is a plumber's assistant.

She is paid an additional \$1.75 per hour for working in a confined space. Her usual rate is \$9.50 per hour.

How much will she earn for working in a confined space for 8 hours?

(A) \$14.00

(B) \$23.50

(C) \$77.75

(D) \$90.00

29

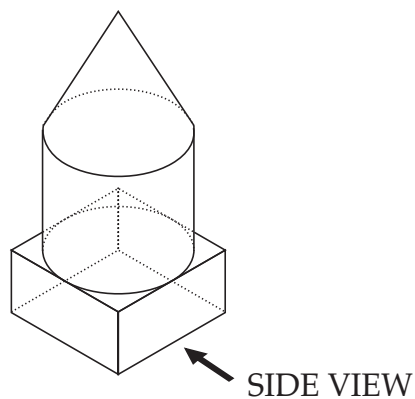

Which of the following represents the side view of this solid?

(A)

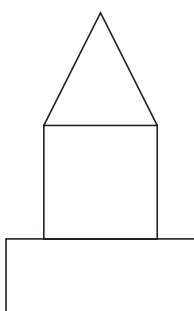

(B)

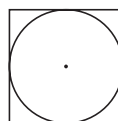

(C)

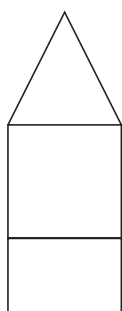

(D)

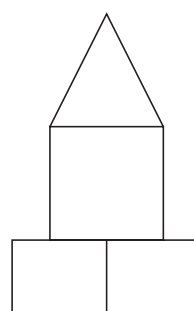

- 30 A consultant's fee is \$245 for eight hours work. To calculate her earnings (E) over a period of time she uses the formula

$$E = \frac{245n}{8}$$

What does n represent?

- (A) The earnings per day
- (B) The number of days worked
- (C) The number of hours worked
- (D) The earnings per hour

- 31 The table shows the distance between towns.

<i>Dover</i>	1160	880	387	210
	<i>Bass</i>	539	1371	958
		<i>Milf</i>	966	560
			<i>Oxley</i>	479
				<i>Hume</i>

The distance between Bass and Hume is 958 km.
Fatima travelled from Milf to Hume and then from Hume to Dover.

How far did she travel altogether?

- (A) 350 km (B) 560 km (C) 770 km (D) 880 km
-
- 32 A mobile phone company is offering mobile phones, with conditions. These conditions are:

- a purchase price of \$10
- an initial connection fee of \$65
- a connection for at least 18 months
- an access fee of \$30 per month.

What is the total minimum cost for the first 18 months (excluding phone calls)?

- (A) \$435 (B) \$540 (C) \$605 (D) \$615
-
- 33 How many 5 cm cubes can be packed in a box which measures 10 cm by 10 cm by 10 cm?

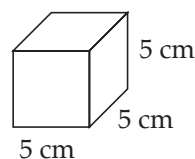
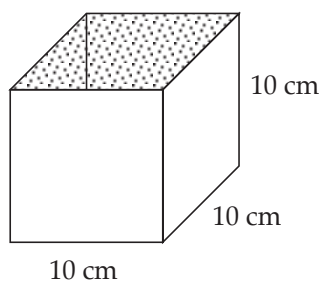

NOT TO SCALE

- (A) 4 (B) 8 (C) 10 (D) 16
-

34

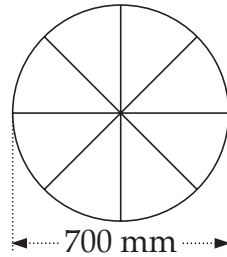

Ted's bicycle wheel has a diameter of 700 mm.

Approximately how far does his bicycle travel when the wheel makes 10 revolutions?

- (A) 2 m (B) 7 m (C) 20 m (D) 44 m

35

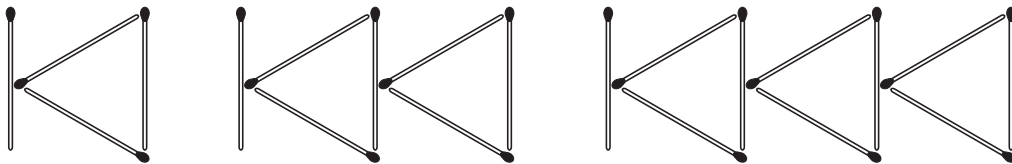

For the pattern, Kim writes the rule, 'the number of matches equals three times the number of triangles plus one'.

Using $m =$ the number of matches
 $t =$ the number of triangles,

the rule may be written as

- (A) $m = 3t + 1$ (B) $3m = t + 1$
 (C) $m + 1 = 3t$ (D) $3m + 1 = t$

36

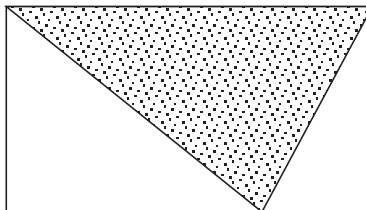

The shaded area in the rectangle represents 5 square metres.

The ratio of the shaded area to the unshaded area is

- (A) 1 : 1 (B) 1 : 2 (C) 1 : 3 (D) 2 : 1

37 Which of the following containers has a capacity of 1 litre?

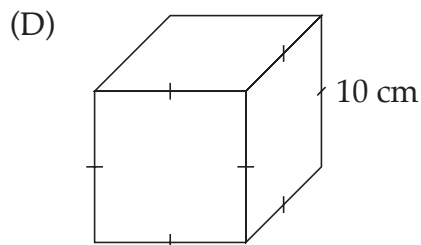
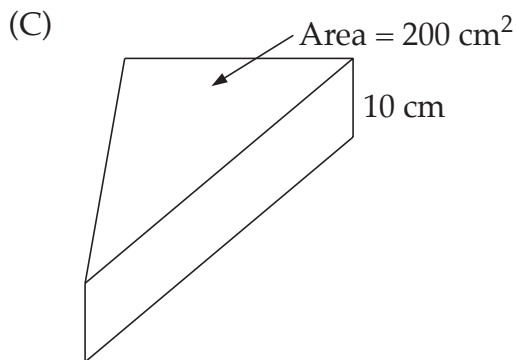
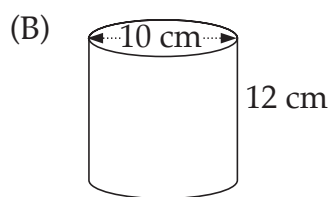
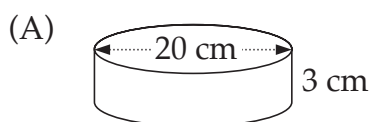

38 A tap drips 8 times per second.
Five drops make 1 mL.

How much water drips in 1 hour?

- (A) 2.4 L (B) 5.76 L (C) 96 L (D) 144 L

39 Which graph represents the rule, 'each y -value is twice the x -value'?

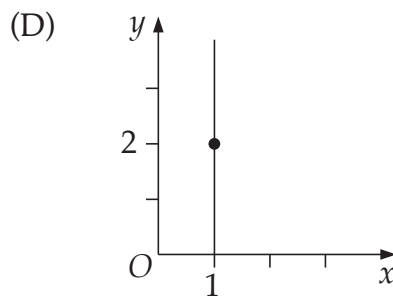
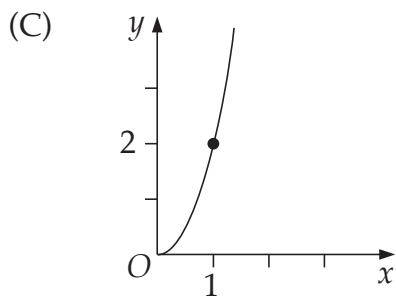
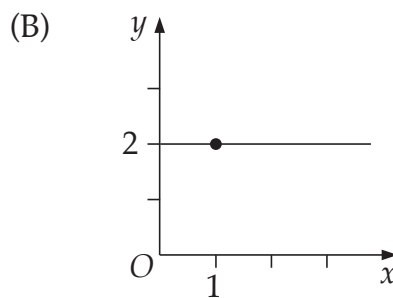
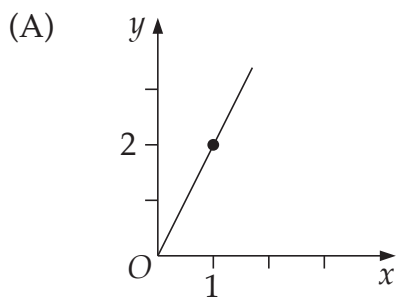

- 40 Keryn paid \$9 for a leg of lamb which weighed one kilogram. When the bone and fat were removed, she had 750 g of meat that she could use.

What was the price per kilogram of the meat she could use?

- (A) \$2.25 (B) \$6.75 (C) \$11.25 (D) \$12.00

- 41 This graph can be used to convert between Australian dollars, English pounds and New Zealand dollars.

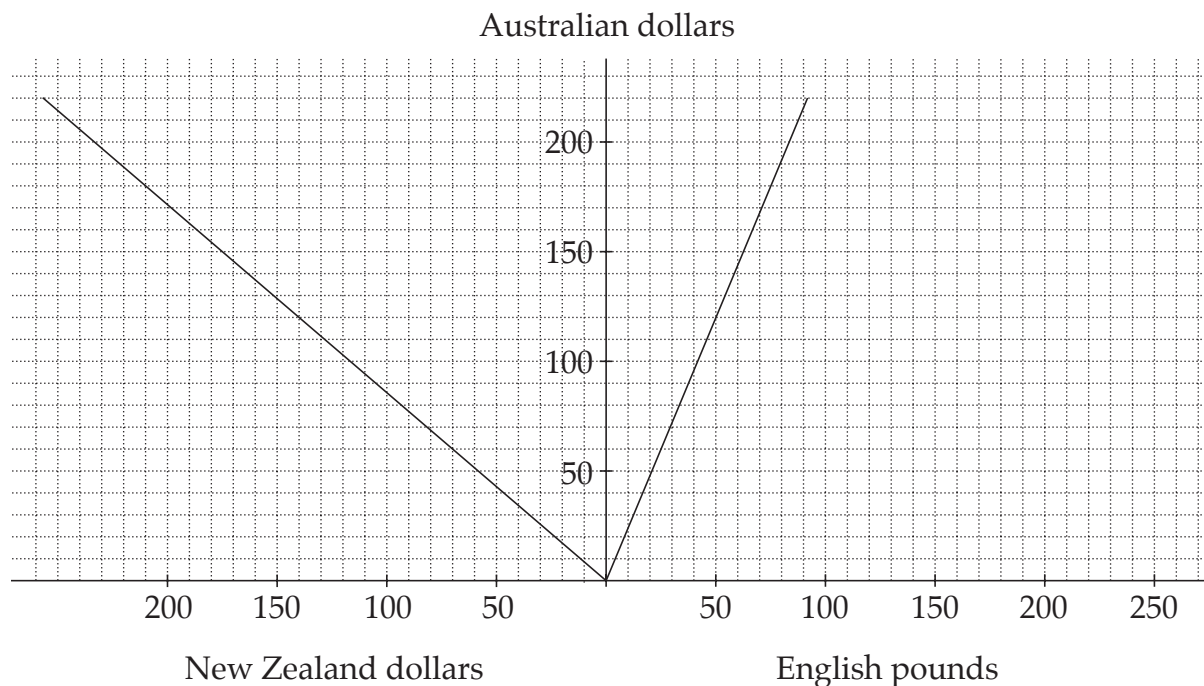

How many New Zealand dollars are equivalent to 50 English pounds?

- (A) 18 (B) 20 (C) 60 (D) 140
- 42 At a school there are 100 boys and 140 girls. The school surveys the students about their favourite TV channel.

Which sample would provide the most reliable results?

- (A) 50 boys and 70 girls
 (B) The first 100 students to arrive at school
 (C) 40 boys and 40 girls
 (D) 10 boys and 14 girls

- 43 The daily traffic flow on a road in January was 54 738. This was 12% lower than in December.

The daily traffic flow in December was

- (A) 6569 (B) 48 169 (C) 61 307 (D) 62 202

- 44 A shop owner has the word APPLES painted on the outside of his window.

What does he see from inside the window?

- (A) SELPPA (B) ƆEJPPA (C) ƆEJPPA (D) SELPPA

45

TICKET PRICES					
	<i>Adult</i>	<i>Child</i>	<i>Senior pensioner</i>	<i>Family (2 adults + 2 children)</i>	<i>Extra child</i>
Zoo including Ferry	\$24.80	\$12.30	—	—	\$8.00
Funland	\$38.40	\$26.80	\$26.00	—	\$25.00
Mountain Highlights	\$42.20	\$17.60	\$28.00	\$99.00	Free
Mountain Explorer Bus	\$29.20	\$10.60	\$16.00	\$69.00	Free

A family which includes 2 adults, their 3 children and 2 senior pensioners buys tickets for Mountain Highlights.

The lowest amount they could pay for their tickets is

- (A) \$101 (B) \$122.20 (C) \$155 (D) \$193.20

- 46 The amount of usable timber in a tree is calculated using the formula

$$v = 0.5hd^2 + 10$$

where d = the diameter of the tree
 h = the height to the first branch
 v = amount of usable timber, in cubic metres.

The amount of usable timber in this tree, to two decimal places, is

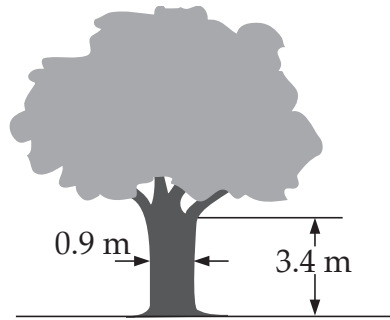

- (A) 11.38 m^3 (B) 11.53 m^3 (C) 12.34 m^3 (D) 15.20 m^3
-

- 47 A four-sided figure has

- two pairs of equal sides, and
- one axis of symmetry.

The figure must be a

- (A) kite.
(B) parallelogram.
(C) rectangle.
(D) trapezium.
-

- 48 A teacher recorded the number of days that her students were absent.

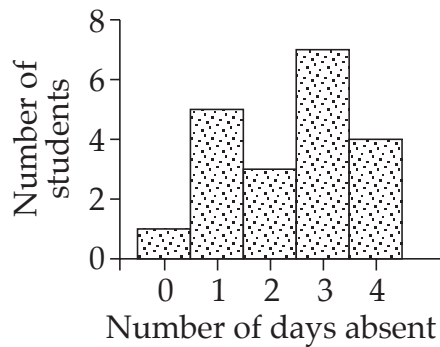

A student is chosen at random.

The probability that this student had 3 days absent is

- (A) $\frac{3}{20}$ (B) $\frac{7}{20}$ (C) $\frac{3}{7}$ (D) $\frac{7}{8}$

- 49

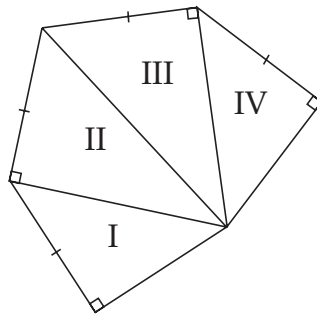

The diagram shows four triangles labelled I, II, III and IV.

Which statement is true?

- (A) Triangle I is congruent to triangle II.
 (B) Triangle I is congruent to triangle III.
 (C) Triangle I is congruent to triangle IV and triangle II is congruent to triangle III.
 (D) Triangle I is congruent to triangle II and triangle III is congruent to triangle IV.

- 50 A fuel tank can hold 84 litres.
The gauge shows the amount of fuel in the tank.

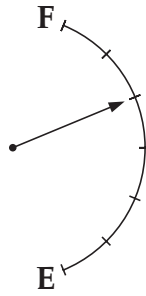

How much fuel is needed to fill the tank?

- (A) 24 L (B) 28 L (C) 56 L (D) 60 L
-

Complete your answers to Questions 51–69 on the Section 2—Part A—Answer Sheet 4.

- 51 Write the decimal value represented by P .

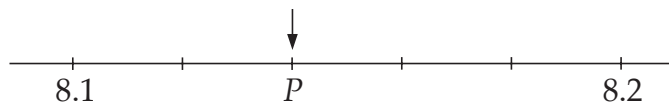

- 52 Simone is facing a tower on a bearing of 045° .
She turns to face another tower on a bearing of 350° .

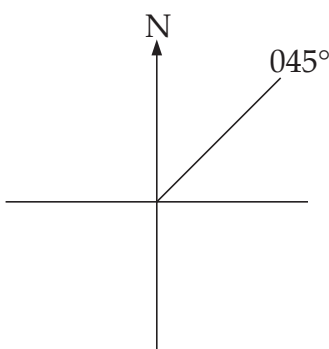

What is the smallest angle through which Simone could have turned?

- 53 Every day Winnie arrives 5 minutes late for work.
Each year she works 5 days per week for forty-eight weeks.

Find the total number of hours that Winnie is late in one year.

- 54 A cube has the corners removed as shown.

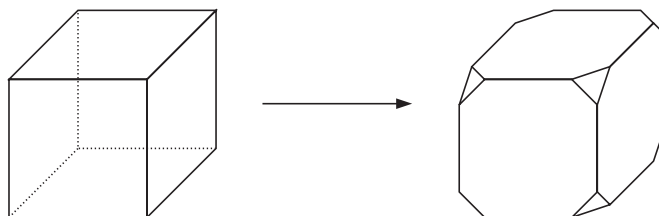

How many edges does the new shape have?

- 55 In a tennis tournament, players need to win their matches to progress to the next round.

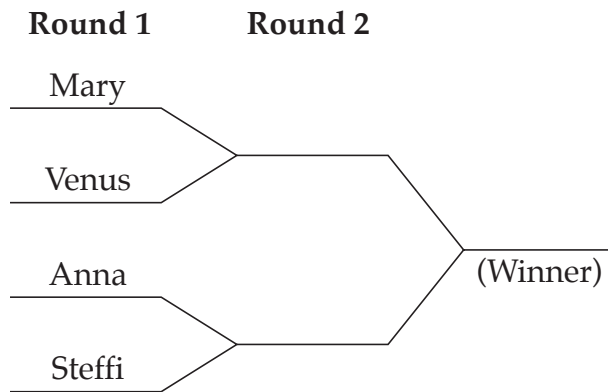

If there are 4 players, the winner plays 2 matches, as shown.

How many matches does the winner play if there are 64 players?

- 56

TRAIN TIMETABLE					
		am	am	am	am
Beronga		10:00	10:21		10:57
Kerang		10:04	10:25		
Aston		10:09	10:30		
Hornbel	arrival	10:12	10:33		11:06
	departure	10:13	10:43	10:42	11:07
Epson			10:51	10:56	11:16
Stratton		10:20		11:15	11:27
Rhodes		10:45	11:22	11:27	11:35

Elise lives at Beronga and is meeting a friend at 11:30 am.
The meeting place is a 10-minute walk from Stratton station.

What is the latest train she can catch from Beronga to be at the meeting on time?

57 This graph shows the temperatures during a day.

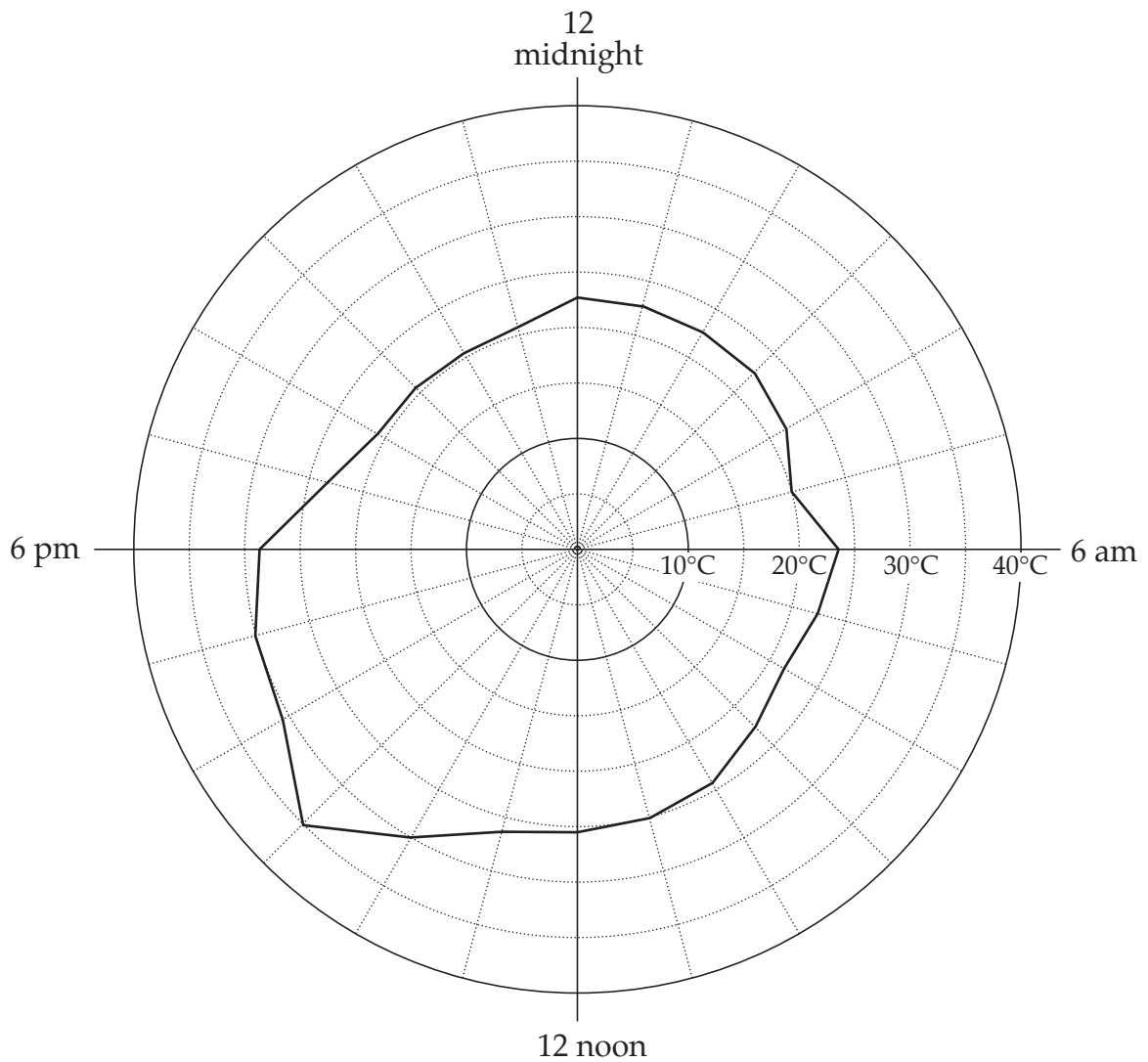

What is the range in temperature for that day?

58 The following stem-and-leaf plot represents the results of a class project.

Boys		Girls
0 0	5	0
9 8 6 4	4	2 4
8 7 5	3	3 4 7
6	2	6 7
8	1	2 4
	0	7

What is the difference between the medians for boys and girls?

59 There are 7.2 million employees in Australia.
This number increases by 3 hundred thousand per year for twelve years.

How many employees will there be at the end of the twelve years?

60

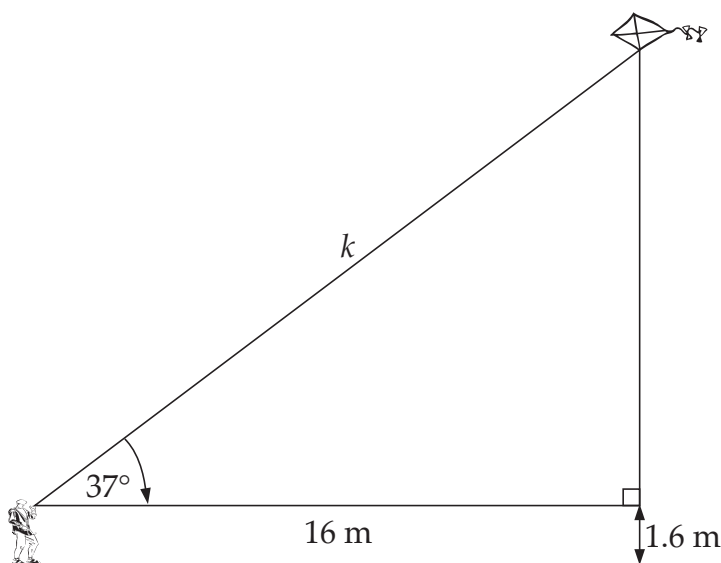

The string of the kite makes an angle of 37° with the horizontal as shown in the scale drawing.

Find the length of the string k (correct to one decimal place).

- 61 The perimeter of a rectangle is 20 centimetres.
The lengths of the sides are whole centimetres.

Give a possible value for the area of the rectangle.

62

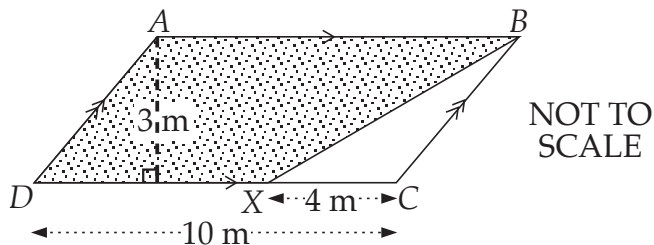

Calculate the shaded area.

- 63 The cost of a taxi fare is calculated using the following table.

TAXI FARE
\$2 hire fee
plus
\$1.70 per km

Peter paid \$27.50 for a taxi fare.

How far did he travel?

64

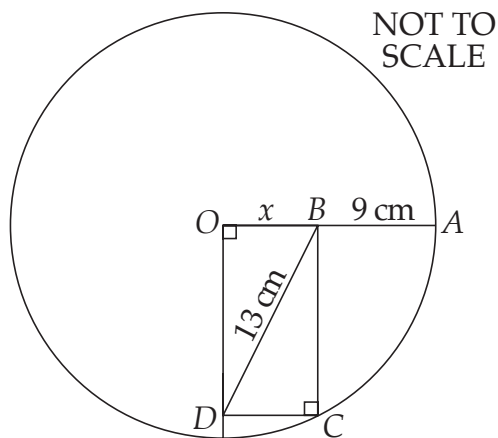

O is the centre of a circle.

OA is a radius.

$OBCD$ is a rectangle.

Find the value of x .

Each of Questions 65, 66, 67, 68 and 69 may have MORE THAN ONE correct answer. Fill in EVERY correct answer for each of these questions on Section 2—Answer Sheet 4.

65

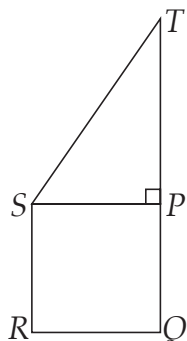

$PQRS$ is a square.

$QR = 10$ cm.

What additional information will allow you to calculate the area of $QRST$?

- (A) PQ (B) PR (C) QT (D) ST

66 Which of the following are true statements?

(A) $a - a \times a = a$

(B) $a + a - a = a$

(C) $a \times a \div a = a$

(D) $a \div a \times a = a$

67 Which of the following represents 0.2?

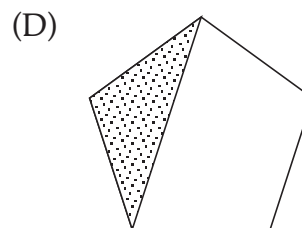
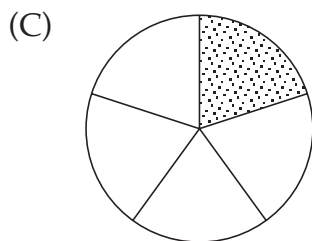
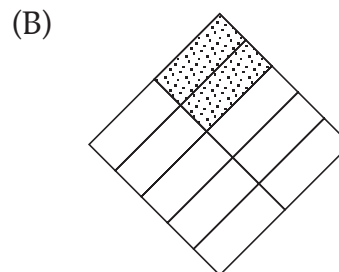
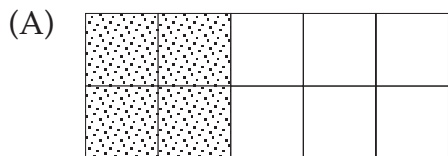

68 A solution to an equation is $C = 40$.

The question could have been

(A) $2C^2 = 3200$

(B) $C^2 = \sqrt{50^2 \pm 30^2}$

(C) $C = 9 \times 5 - 85$

(D) $95 = 5 \times 11 + C$

69 The net of a cube is shown.

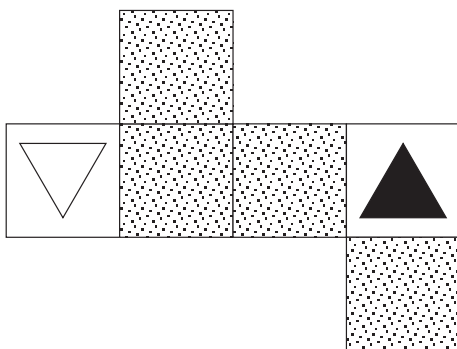

Which of the following could this cube be?

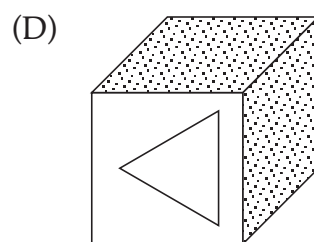
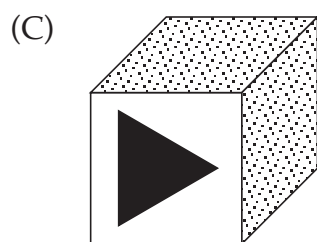
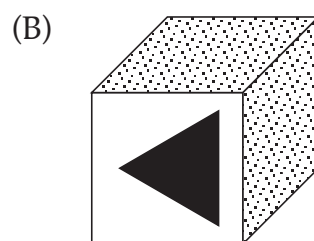
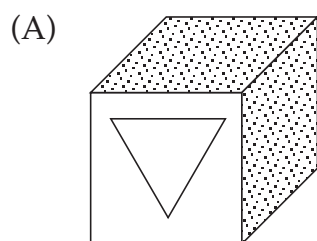

End of questions in Section 2 Part A that may require you to fill in more than one correct answer.

Complete your answers to Questions 70–75 in this booklet.

70 AB represents the runway at an airport.

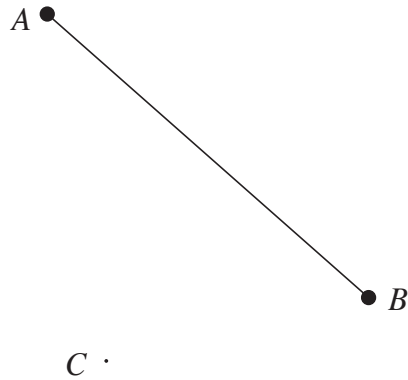

A second runway is to be built through C , perpendicular to AB . Complete the diagram to show the new runway.

71 Three views of a three-dimensional shape are shown below.

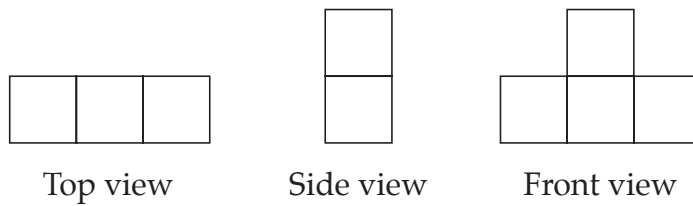

Complete the drawing of this shape.

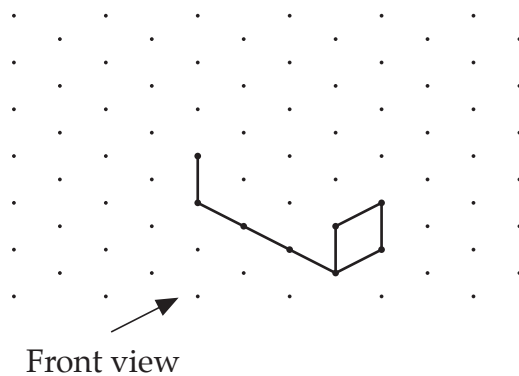

Use the following diagram to answer Questions 72 and 73.

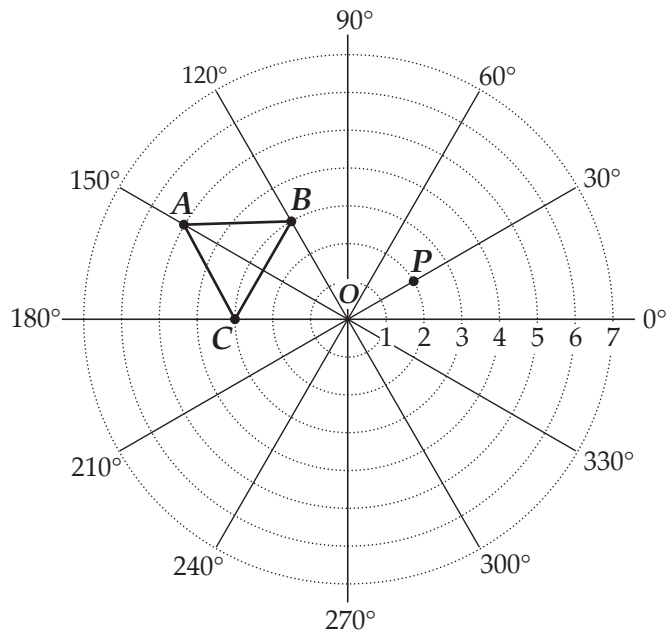

72 P has coordinates $(2, 30^\circ)$

P is rotated 180° about O .

What are the new coordinates of P ?

$(\boxed{}\boxed{}\boxed{}, \boxed{}\boxed{}\boxed{}^\circ)$

73 Triangle ABC is rotated 90° clockwise about O .

Draw the triangle in its new position.

Use the following diagram to answer Questions 74 and 75.

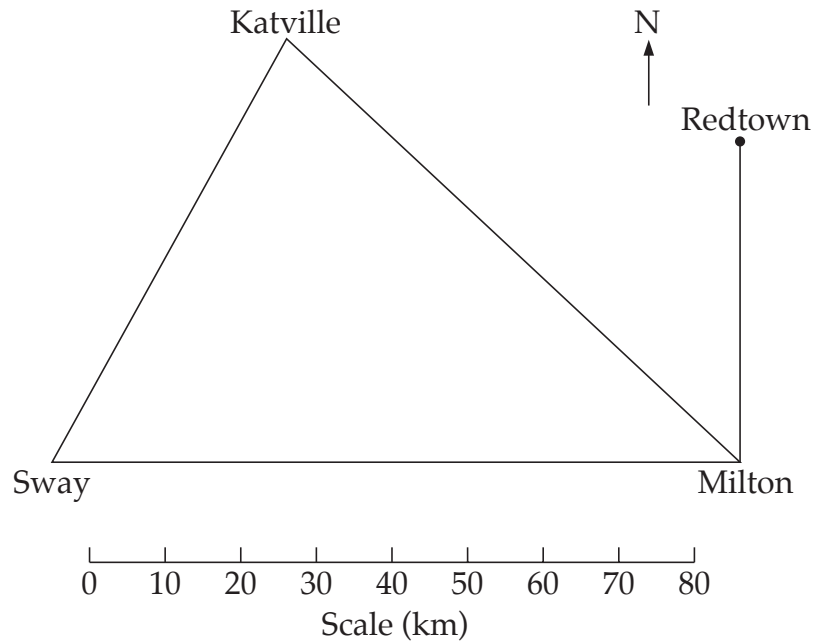

- 74 Lindhurst is located on the road from Katville to Milton.
The road from Sway to Lindhurst bisects the angle made by the roads at Sway.
Use geometrical instruments to draw the road from Sway to Lindhurst.
- 75 Hatson is 80 km from Katville and 35 km from Milton.
It is east of the road from Milton to Redtown.
Mark the position of Hatson with an \times .

End of Section 2 Part A

Go on to Part B

BLANK PAGE

BLANK PAGE