

BOARD OF STUDIES  
NEW SOUTH WALES

**2000  
SCHOOL  
CERTIFICATE  
TEST**

**7 November  
Start 9.25 am**

**MATHEMATICS**

**SECTION 1**

**25 marks**

**CENTRE NUMBER**

--	--	--	--	--

**STUDENT NUMBER**

--	--	--	--	--	--	--	--	--	--

## General Test Instructions

- Reading time: 5 minutes
- Working time: 2 hours
- The supervisor will tell you when to begin the test
- This test has TWO sections
- Attempt ALL questions
- There will be a short break between Section 1 and Section 2
- Calculators may be used in Section 2 only
- The Sample Questions and Formulae Booklet may be used in both sections

## Directions for Section 1

- 1 You have 30 minutes to answer this section
- 2 Write your answers to Questions 1–25 in this booklet
- 3 Calculators are NOT to be used in Section 1
- 4 Complete your answers in either blue or black pen
- 5 Write your Centre Number and Student Number at the top of this page

Complete your answers to Questions 1–25 in this booklet.

1 Write  $7.4265$  correct to 2 decimal places.

.....

2 Evaluate  $54.7 \times 100$ .

.....

.....

3 Find the value of  $2^3 + 3^2$ .

.....

.....

4 Write a decimal that lies between  $\frac{1}{2}$  and  $\frac{3}{4}$ .

.....

.....

5 Evaluate  $0.4 \times 0.2$

.....

.....

6 Mark, on this scale, the probability of throwing a 'four' with one roll of a dice.

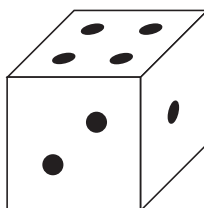
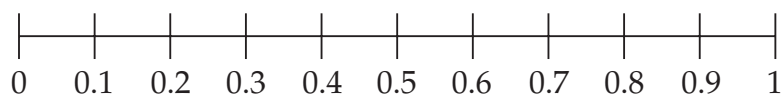

7 Reflect the parallelogram  $DEFG$  in the line  $AB$ .

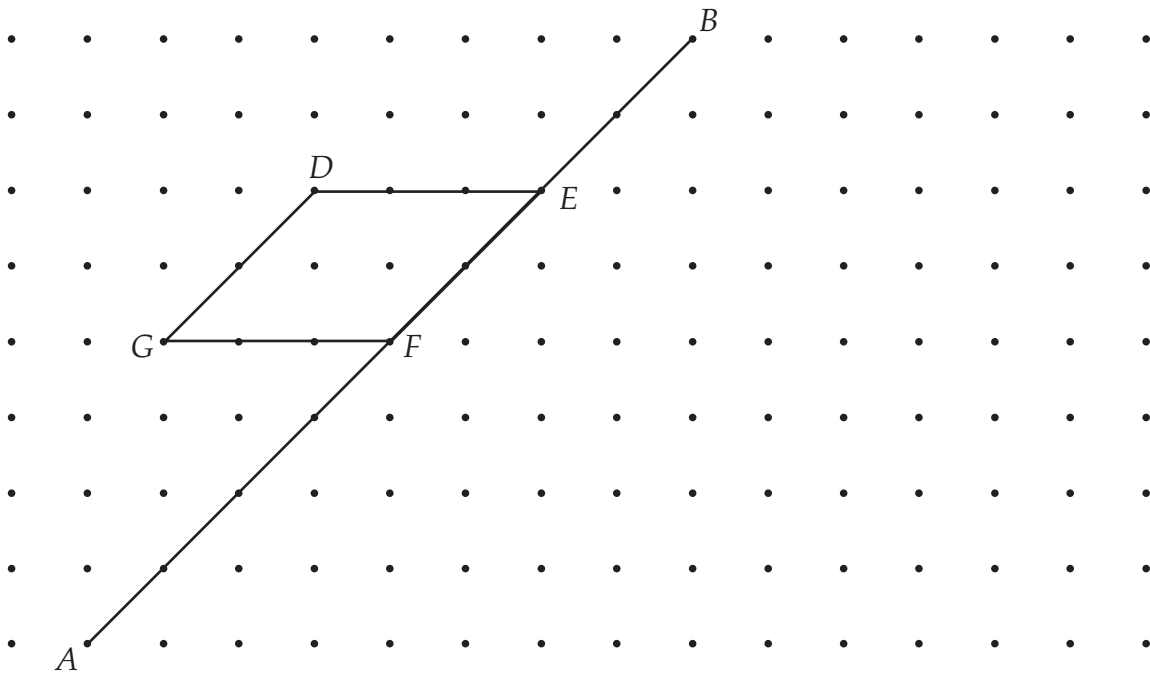

Questions 8 and 9 refer to the sector graph.

8

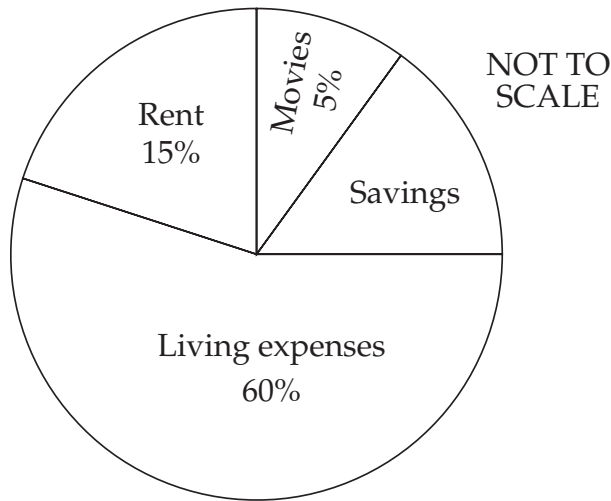

The sector graph shows how Phil spends his weekly wage.  
 What fraction of his weekly wage does he save? (Answer in simplest form.)

.....  
 .....

9 Phil's weekly rent is \$75.  
 Calculate his living expenses.

.....  
 .....

10 By how much is  $\frac{1}{2}$  greater than  $\frac{3}{8}$ ?

.....  
 .....

11 The expression  $\frac{10 + \square}{3}$  has a value between 6 and 8, where  $\square$  is a whole number.

What is a possible value for  $\square$ ?

.....  
 .....

12 Evaluate  $15 \times 99$ .

.....  
 .....

13 Write a description of a trapezium.

.....  
 .....

14 If  $7! = 7 \times 6 \times 5 \times 4 \times 3 \times 2 \times 1$  and  $5! = 5 \times 4 \times 3 \times 2 \times 1$ ,  
 find the value of  $\frac{7!}{5!}$ .

.....  
 .....

15

Score	Frequency
1	4
2	<input type="text"/>
3	3
4	<input type="text"/>
5	2
	20

Write a number in each box so that this set of 20 scores has a median of 3.

16 Mario walked from home to the local shop. At the shop he had a drink and a rest before returning home. He arrived home at 10 am.

Complete the diagram to make a possible travel graph of his outing.

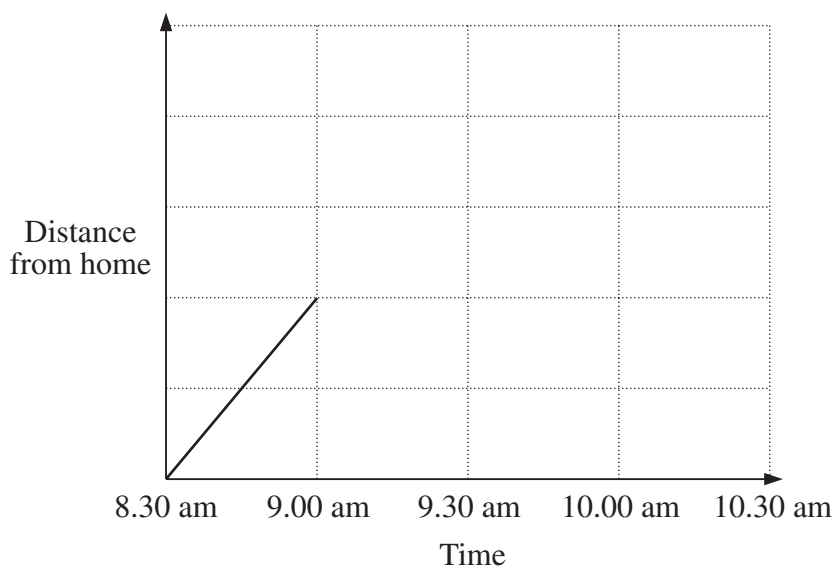

17 Write  $\frac{2}{3}$  as a repeating decimal.

.....

.....

18 Use the grid to draw a *triangle* with an area of 6 square centimetres.

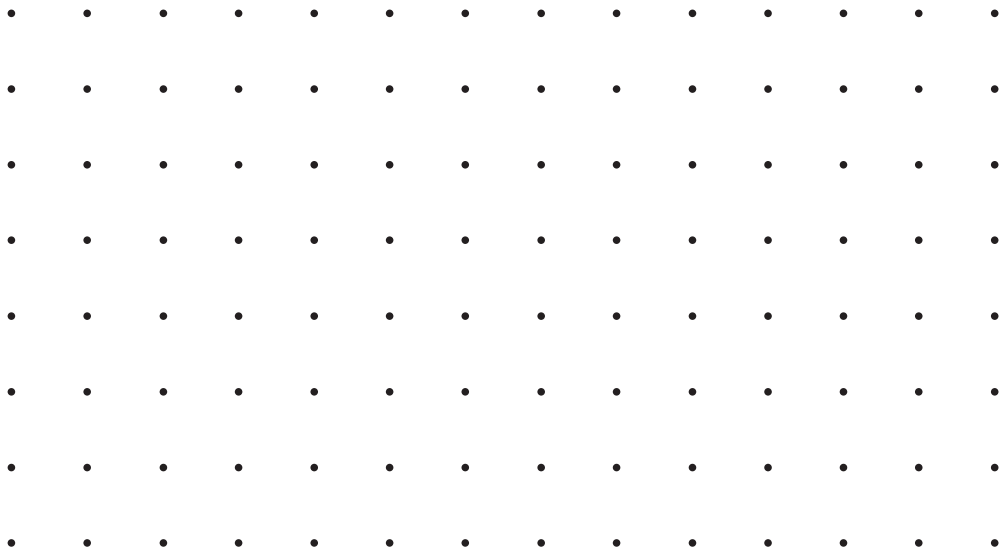

19 A bag contains 350 coins. Dimitrios takes four fifths of the coins out of the bag and divides them into 7 equal groups.

How many coins are in each group?

.....  
 .....

20 The symbol  $\psi$  stands for 'double and add 3'.

$$\begin{aligned} \text{For example, } \psi(4) &= 2 \times 4 + 3 \\ &= 11 \end{aligned}$$

Evaluate  $\psi(8)$ .

.....  
 .....

21 Consider the pattern

$$\begin{aligned} 3^2 - 2^2 &= 3 + 2 = 5 \\ 4^2 - 3^2 &= 4 + 3 = 7 \\ 5^2 - 4^2 &= 5 + 4 = 9 \end{aligned}$$

Use the pattern to complete:

$$29^2 - 28^2 = \boxed{\phantom{00}} + \boxed{\phantom{00}} = \boxed{\phantom{00}}$$

- 22 Fred is one year older than Bill and one year younger than Mary.  
The sum of all their ages is 15.

Calculate the product of their ages.

.....  
.....

- 23 Chris is travelling at 90 km/h.

Given that 18 km/h is the same as 5 m/s, how far does Chris travel in one second?

.....  
.....

- 24 Write a set of 4 scores with a range of 8 and a median of 7.

--	--	--	--

- 25 Soula is constructing a triangle  $XYZ$ .  
 $Z$  lies on the dotted line.  
The angle at  $X$  is half the size of the angle at  $Y$ .

Complete the triangle to accurately show the position of  $Z$ .

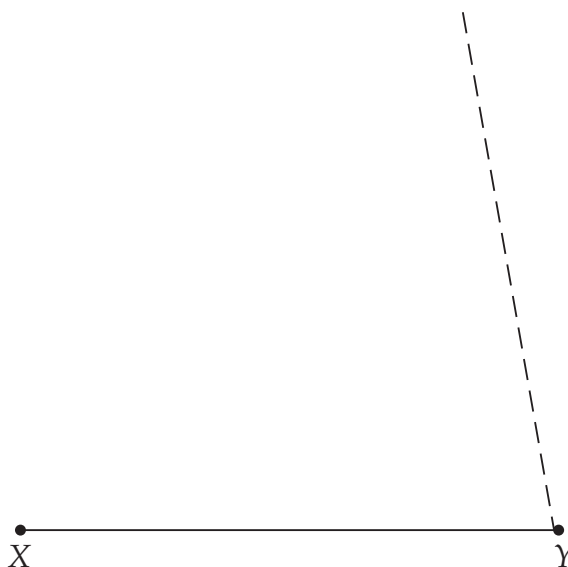

**End of Section 1**

BLANK PAGE



BOARD OF STUDIES  
NEW SOUTH WALES

**2000  
SCHOOL  
CERTIFICATE  
TEST**

**7 November**

**MATHEMATICS**

**SECTION 2**

**Part A**

**50 marks**

## Directions for Section 2 Part A

- 1 You have 90 minutes to answer Section 2 Part A and Section 2 Part B
- 2
  - Part A Questions 26–75
  - Allow about 60 minutes to answer this part
- 3
  - All questions in Part A are multiple choice
  - Each question has only one correct answer
  - Complete your answers to this part on the Answer Sheet
- 4 Calculators may be used in Section 2
- 5 Complete your answers in either blue or black pen

Complete your answers to Questions 26–75 on the Section 2 Part A—Answer Sheet.

26 Calculate  $\frac{53.7}{1.9 + 2.7}$  correct to 1 decimal place.

- (A) 11.6                      (B) 11.7                      (C) 30.9                      (D) 31.0
- 

27  $5x - 7y + 3x + y =$

- (A)  $2x - 6y$                       (B)  $2x - 8y$                       (C)  $8x - 6y$                       (D)  $8x - 8y$
- 

28 Which of these solids has a volume different from the others?

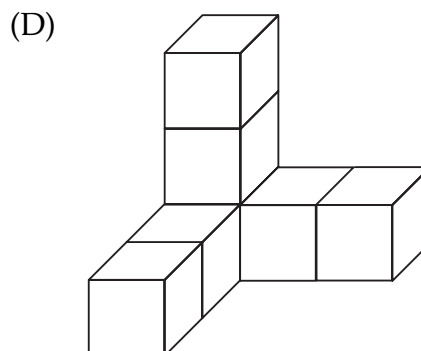
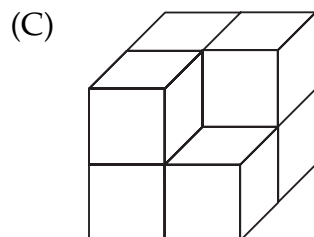
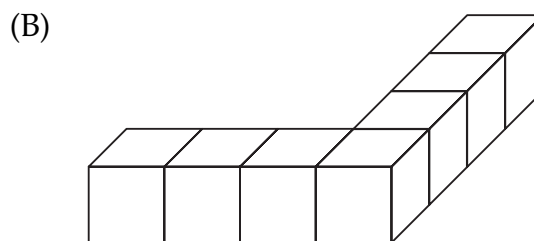
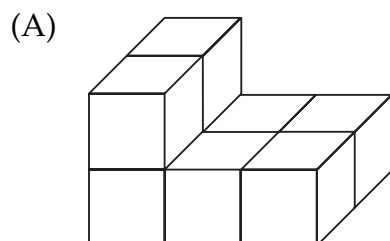

29 A compact disc player is marked at \$120.  
A retailer offers a 15% discount.

Calculate the discounted price.

- (A) \$18                      (B) \$102                      (C) \$105                      (D) \$112
- 

30 4.7 kg is equivalent to

- (A) 0.0047 t                      (B) 0.047 g                      (C) 0.47 t                      (D) 470 g
-

31 Which of these solids is a prism?

(A)

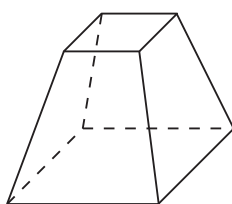

(B)

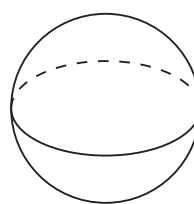

(C)

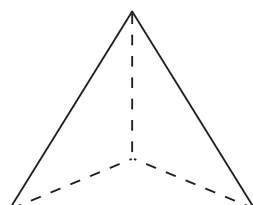

(D)

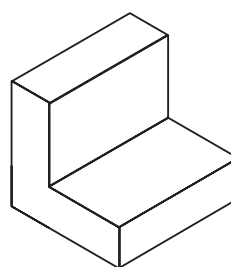

---

32 A recipe for hummus includes 300 g chick peas and 2 tablespoons of sesame seeds. These quantities make 4 servings.

Anji uses 3 tablespoons of sesame seeds.

Which statement is correct?

- (A) She needs 400 g chick peas and can make 5 servings.
- (B) She needs 450 g chick peas and can make 5 servings.
- (C) She needs 400 g chick peas and can make 6 servings.
- (D) She needs 450 g chick peas and can make 6 servings.

---

33 Stephanie took 36 photos on a roll of film.  
When the film was developed only 27 photos were printed.

What percentage of photos were NOT printed?

- (A) 9%
  - (B) 25%
  - (C) 33%
  - (D) 75%
-

34 Which two rectangles are similar?

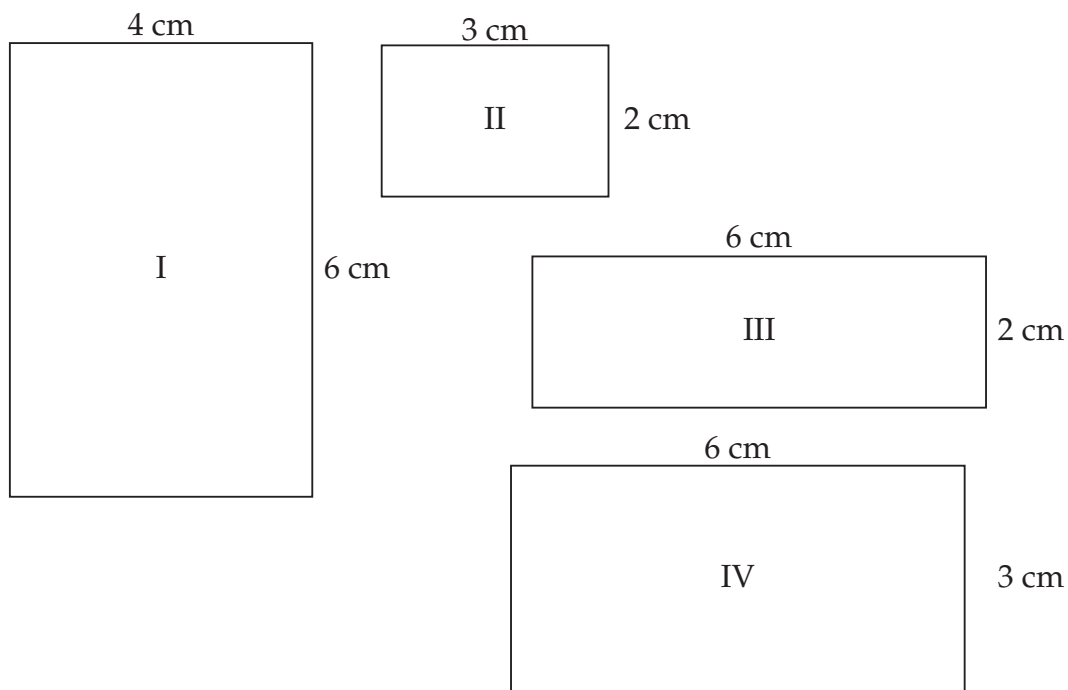

- (A) I and II      (B) II and III      (C) III and IV      (D) I and IV

35

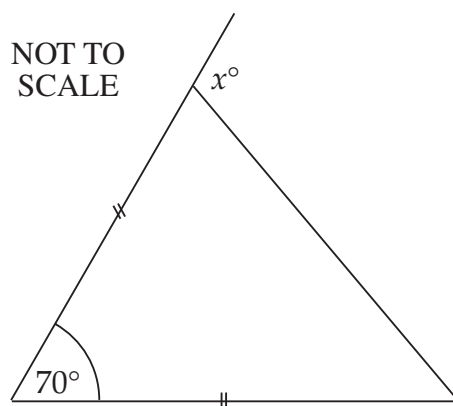

What is the value of  $x$ ?

- (A) 55      (B) 110      (C) 125      (D) 140

36 Three times are given:

7.48 pm;

25 minutes to 8 in the evening;

1940 (24 hour time).

What is the correct order, from earliest to latest of these times?

- (A) 1940; 7.48 pm; 25 minutes to 8 in the evening.  
 (B) 25 minutes to 8 in the evening; 7.48 pm; 1940.  
 (C) 1940; 25 minutes to 8 in the evening; 7.48 pm.  
 (D) 25 minutes to 8 in the evening; 1940; 7.48 pm.

37

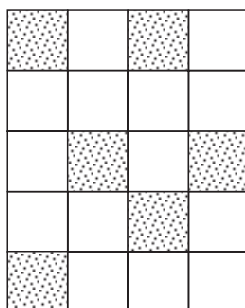

What percentage of this rectangle has been shaded?

- (A) 6%                      (B) 30%                      (C) 43%                      (D) 70%

38 You are considering a part-time job.

Which would pay the most?

- (A) 4 hours at triple rate.  
 (B) 6 hours at the normal rate and 3 hours at double time.  
 (C) 7 hours at the normal rate and 4 hours at time-and-a-half.  
 (D) We cannot say unless the normal rate is known.

39 The statement ' $90 + 185 = 275$ ' illustrates the claim  
 '*a right angle plus a reflex angle can equal a reflex angle*'.

Which statement illustrates the claim  
 '*an acute angle plus an obtuse angle can equal a reflex angle*'?

- (A)  $30 + 165 = 195$                       (B)  $50 + 125 = 175$   
 (C)  $75 + 180 = 255$                       (D)  $95 + 170 = 265$

- 40 When viewed from above, which of these solids has a different TOP VIEW from the others?

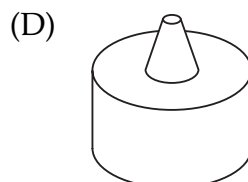
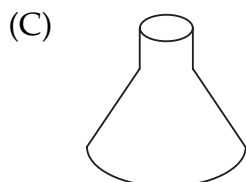
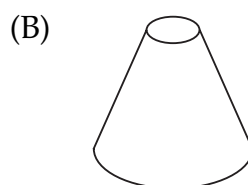
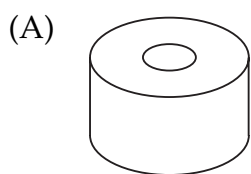

- 41 Which of the following lemonade prices represents the best value for money?

(A) 390 mL for \$0.25

(B) 500 mL for \$0.33

(C) 1.25 L for \$0.75

(D) 2 L for \$1.25

- 42 Which of the following *both* appear in this diagram?

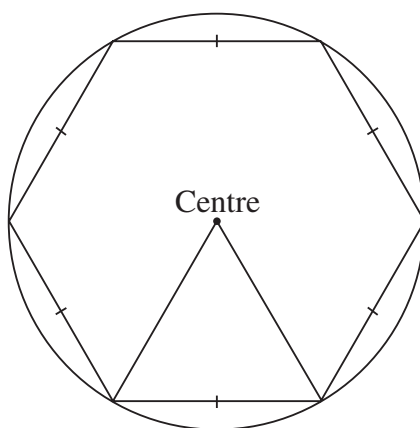

(A) Radius, tangent

(B) Diameter, equilateral triangle

(C) Arc, quadrant

(D) Chord, hexagon

- 43 Which operations are needed to find the value of  $a$ , if  $a^2 + 64 = 100$ ?

(A) Subtract 64 then find the square root.

(B) Subtract 64 then divide by 2.

(C) Add 64 then find the square root.

(D) Add 64 then divide by 2.

44 Which expression does NOT equal  $2a$ ?

- (A)  $a \times a$       (B)  $2 \times a$       (C)  $3a - a$       (D)  $a + a$

45

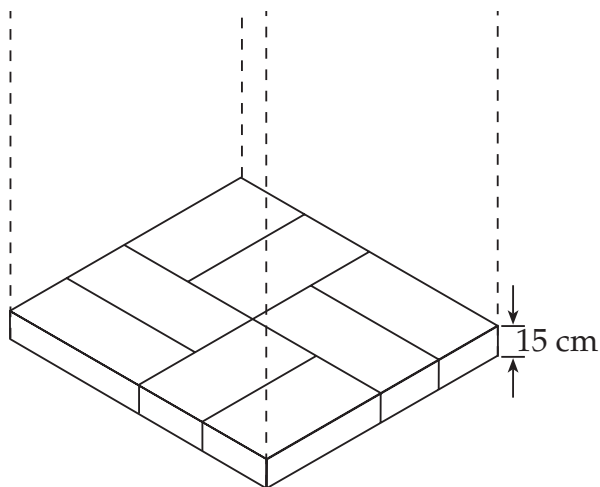

Mr Lee wishes to construct a stack of bricks 3 metres high.

Each layer is to be like the pattern shown in the diagram.

The thickness of one layer of bricks is 15 cm.

How many bricks does he need for the stack?

- (A) 20      (B) 40      (C) 120      (D) 160

46

<i>Stem</i>	<i>Leaf</i>			
1	3	4	6	
2	4	5	5	6
3	2	7	7	9
4	3	4	6	

There are 2 modes for the data presented in the stem-and-leaf diagram.

What are the modes?

- (A) 4 and 6      (B) 5 and 7      (C) 26 and 32      (D) 25 and 37

47 The average weight of 10 people is 74 kg.

If 4 of them weigh 80 kg each, what is the average weight of the remaining 6 people?

- (A) 42 kg      (B) 68 kg      (C) 70 kg      (D) 77 kg

48 Which figure has exactly TWO axes of symmetry?

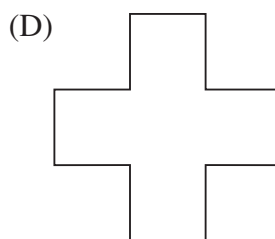
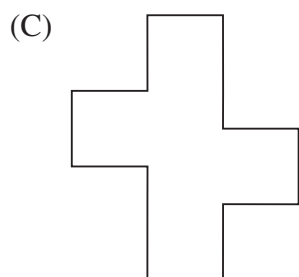
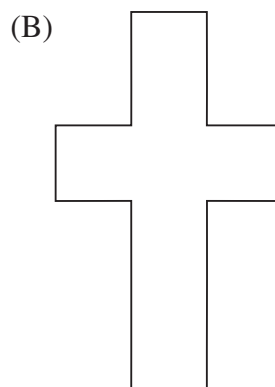
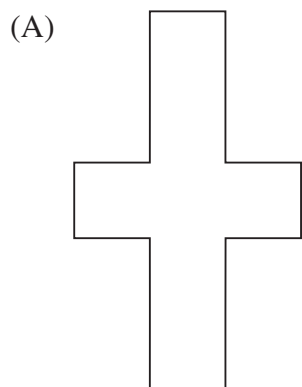

---

49 When it is 12.00 noon in Sydney it is 10.00 am in Perth.  
Zac leaves Sydney at 1.00 pm and flies to Perth.  
The flight takes 5 hours.

What time is it in Perth when he arrives?

- (A) 3.00 pm      (B) 4.00 pm      (C) 6.00 pm      (D) 8.00 pm

---

50 An amount of \$55 000 is to be divided amongst three friends, Chris, Ted and Gloria, in the ratio 3 : 5 : 3.

How much does Ted receive?

- (A) \$5 000      (B) \$11 000      (C) \$15 000      (D) \$25 000
-

51

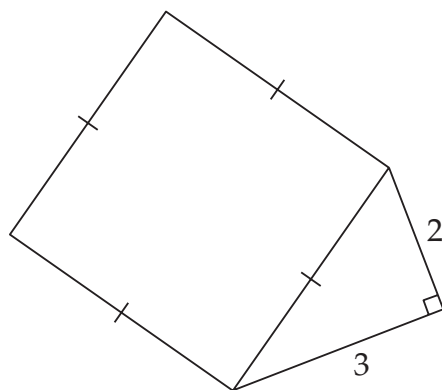

Calculate the area of the square.

- (A)  $\sqrt{5}$  units<sup>2</sup>    (B)  $\sqrt{13}$  units<sup>2</sup>    (C) 13 units<sup>2</sup>    (D) 25 units<sup>2</sup>

52

$x$	-2	-1	0	1	2
$y$	-2	0	2	4	6

What is the correct rule for this table?

- (A)  $y = 2x + 2$     (B)  $y = x + 4$     (C)  $y = x + 2$     (D)  $y = 2x - 2$

53

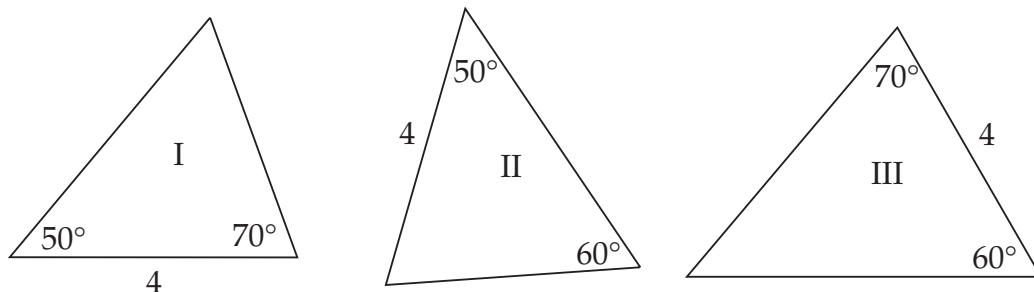

Which triangles are congruent?

- (A) I and II only    (B) I and III only  
 (C) II and III only    (D) I, II and III

54 Nikki wants to record a television program starting at 9.55 am and finishing at 2.17 pm.

How long is the program?

- (A) 3 hours and 22 minutes    (B) 4 hours and 22 minutes  
 (C) 5 hours and 22 minutes    (D) 7 hours and 38 minutes

55

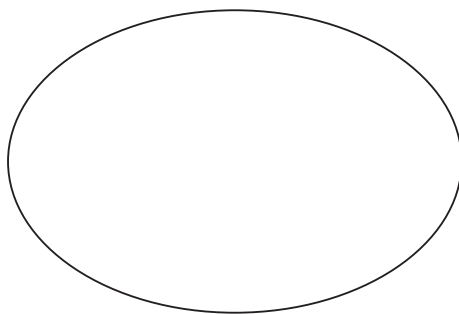

Give the best estimate for the area of this shape.

- (A)  $12 \text{ cm}^2$       (B)  $18 \text{ cm}^2$       (C)  $24 \text{ cm}^2$       (D)  $28 \text{ cm}^2$

56

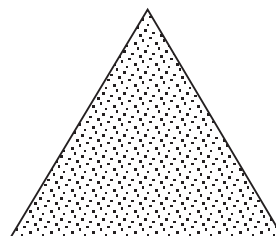
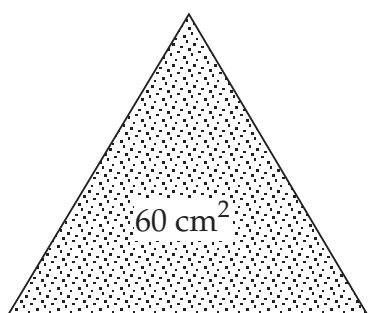

NOT TO  
SCALE

The ratio of the areas of the triangles is 3 : 2.

The area of the larger triangle is  $60 \text{ cm}^2$ .

What is the area of the smaller triangle?

- (A)  $24 \text{ cm}^2$       (B)  $36 \text{ cm}^2$       (C)  $40 \text{ cm}^2$       (D)  $48 \text{ cm}^2$

57 Solve the equation  $2a + 4 = 48$ .

- (A)  $a = 8$       (B)  $a = 20$       (C)  $a = 22$       (D)  $a = 26$

58 You are given the mean of 20 scores.

Which of the following can you calculate?

- (A) The median of the scores  
(B) The range of the scores  
(C) The mode of the scores  
(D) The sum of the scores

59



A satellite is launched from the Earth. At a certain height, it begins to orbit the Earth. The dotted line shows the path of the satellite.

Which graph best shows the distance of the satellite from the Earth, from the time it is launched?

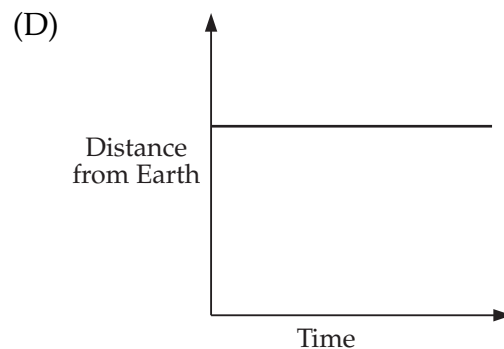
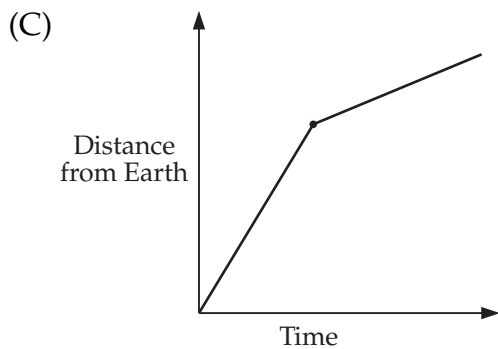
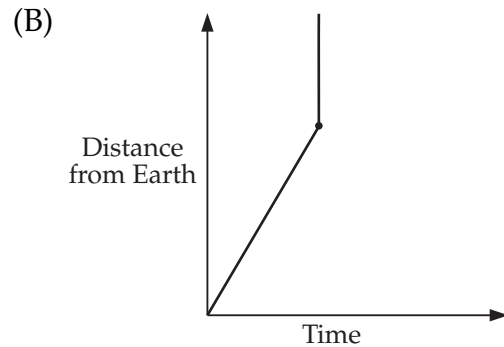
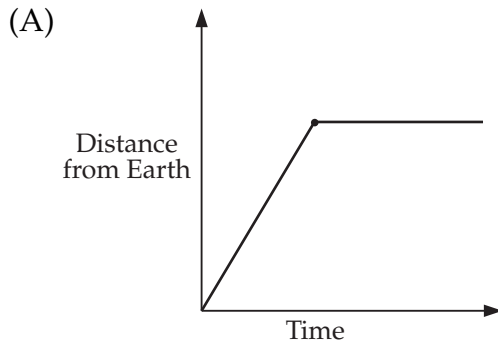

60 Tracey fills her car with 28 litres of petrol at 82.3 cents per litre.

How much change does she get from a \$50 note (to the nearest 5 cents)?

- (A) \$16.00      (B) \$23.05      (C) \$26.95      (D) \$34.00

61 In optics, the formula  $M = \frac{f}{f - d}$  is used where

$M$  = magnification,  $f$  = focal length,  $d$  = distance from lens.

Find  $M$  if  $f = 10$  and  $d = 8$ .

- (A) -7      (B) 0.2      (C) 5      (D) 8

62

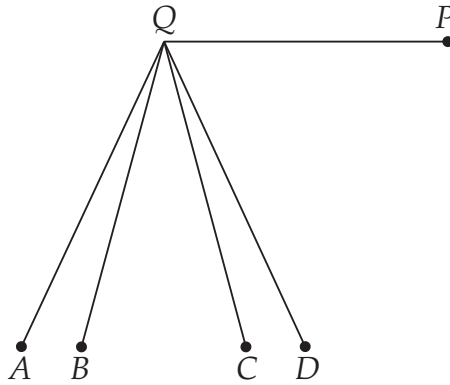

$QP$  is one arm of a reflex angle measuring  $255^\circ$ .

Which is the other arm of the angle?

- (A)  $QA$                       (B)  $QB$                       (C)  $QC$                       (D)  $QD$

63

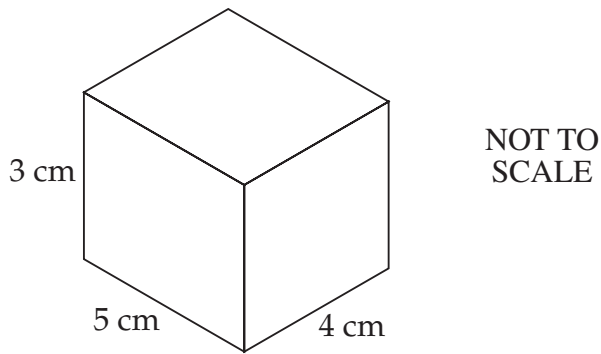

Calculate the surface area of the rectangular prism.

- (A)  $47 \text{ cm}^2$                       (B)  $60 \text{ cm}^2$                       (C)  $90 \text{ cm}^2$                       (D)  $94 \text{ cm}^2$

64 A pipe has an inner radius of 6 cm and an outer radius of 12 cm.

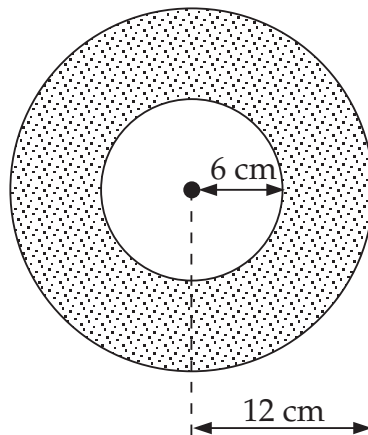

The shaded area in square centimetres is given by

- (A)  $12\pi$ .                      (B)  $36\pi$ .                      (C)  $108\pi$ .                      (D)  $144\pi$ .

65

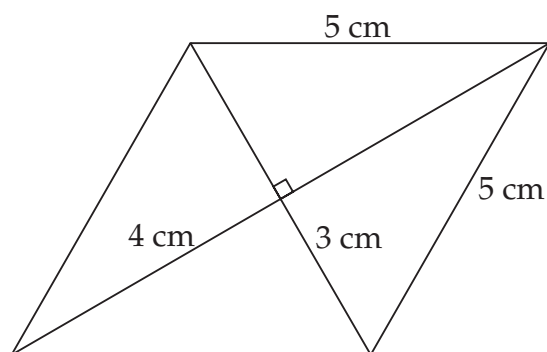
NOT TO  
SCALE

Calculate the area of the rhombus.

- (A)  $12 \text{ cm}^2$       (B)  $24 \text{ cm}^2$       (C)  $25 \text{ cm}^2$       (D)  $48 \text{ cm}^2$

66 Elizabeth has begun to bisect the interval  $PQ$ .

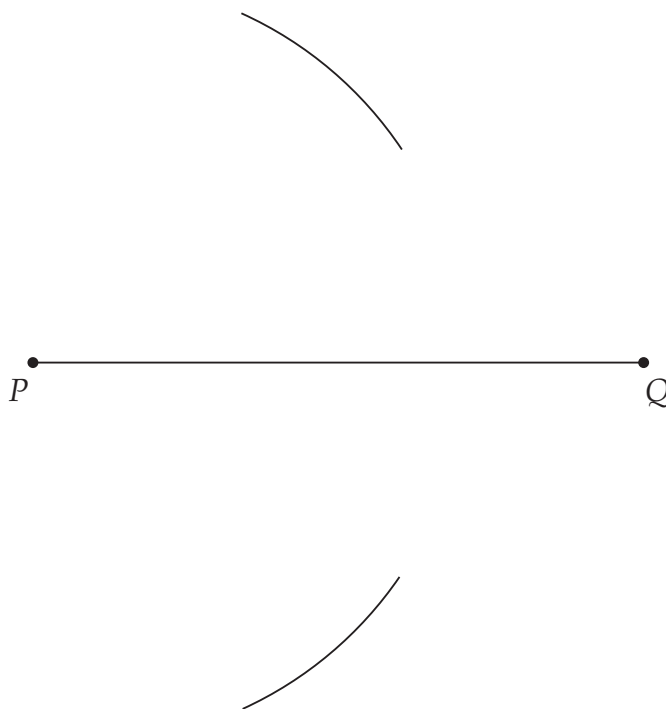

The next three steps, in the *wrong order* are

- 1 Join  $RT$ .
- 2 Draw arcs to cut the previous arcs at  $R$  and  $T$ .
- 3 Put the point of the pair of compasses on  $Q$ .

The *correct order* for the steps is

- (A) 3, 2, 1.      (B) 2, 1, 3.      (C) 2, 3, 1.      (D) 3, 1, 2.

67 The circumference of a circular field is 628 m.

A smaller circular field has a radius of 50 m.

Cathy runs  $1\frac{1}{2}$  laps around the larger field.

How many laps of the smaller field must she complete to run the same distance?

- (A) 2                      (B) 3                      (C) 4                      (D) 5

68

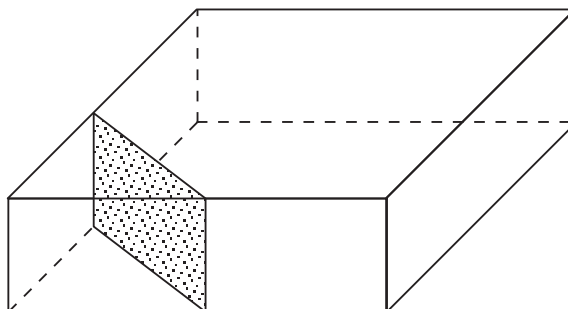

The shaded area shows where a rectangular prism has been cut to form two new solids.

Name these two solids.

- (A) triangular pyramid and hexagonal prism  
 (B) triangular pyramid and pentagonal prism  
 (C) triangular prism and hexagonal prism  
 (D) triangular prism and pentagonal prism

69

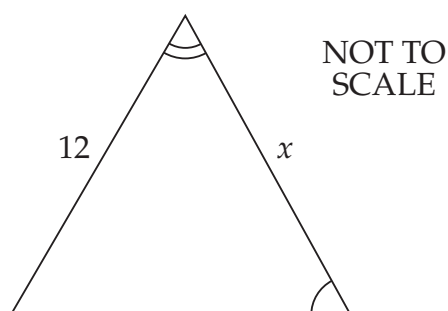
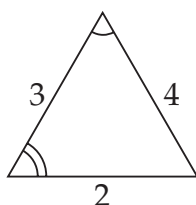

What is the value of  $x$ ?

- (A) 9                      (B) 16                      (C) 18                      (D) 24

70

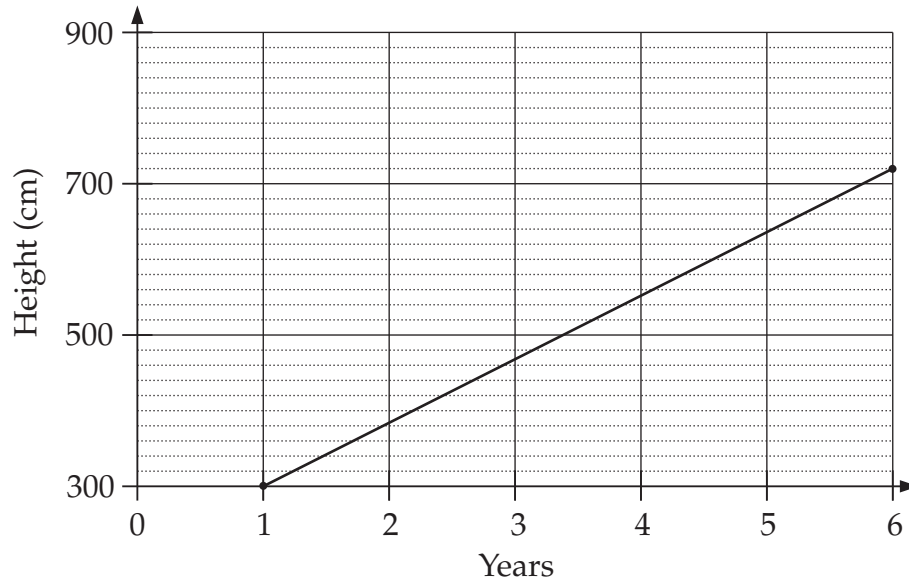

The graph shows the increase in height of a tree over a number of years. Calculate the rate of increase in centimetres per year.

- (A) 70                      (B) 84                      (C) 120                      (D) 144

71 The timeline shows some major events.

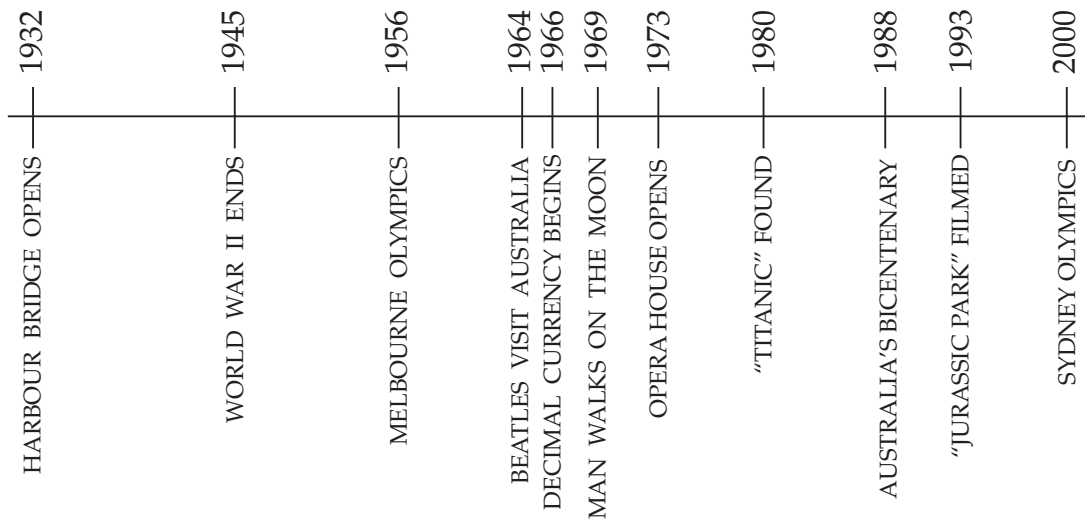

Which event occurred half-way between the opening of the Harbour Bridge and the Sydney Olympics?

- (A) Beatles visit Australia  
 (B) Man walks on the moon  
 (C) Decimal currency begins  
 (D) Opera House opens

72

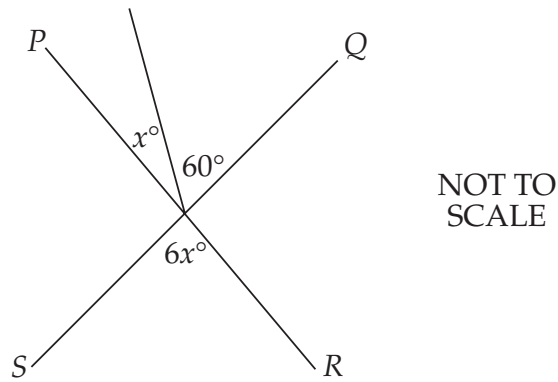

PR and QS are straight lines.

Find the value of  $x$ .

- (A) 10                      (B) 12                      (C) 15                      (D) 30

73 Which diagram shows a road running north-west from position Lk?

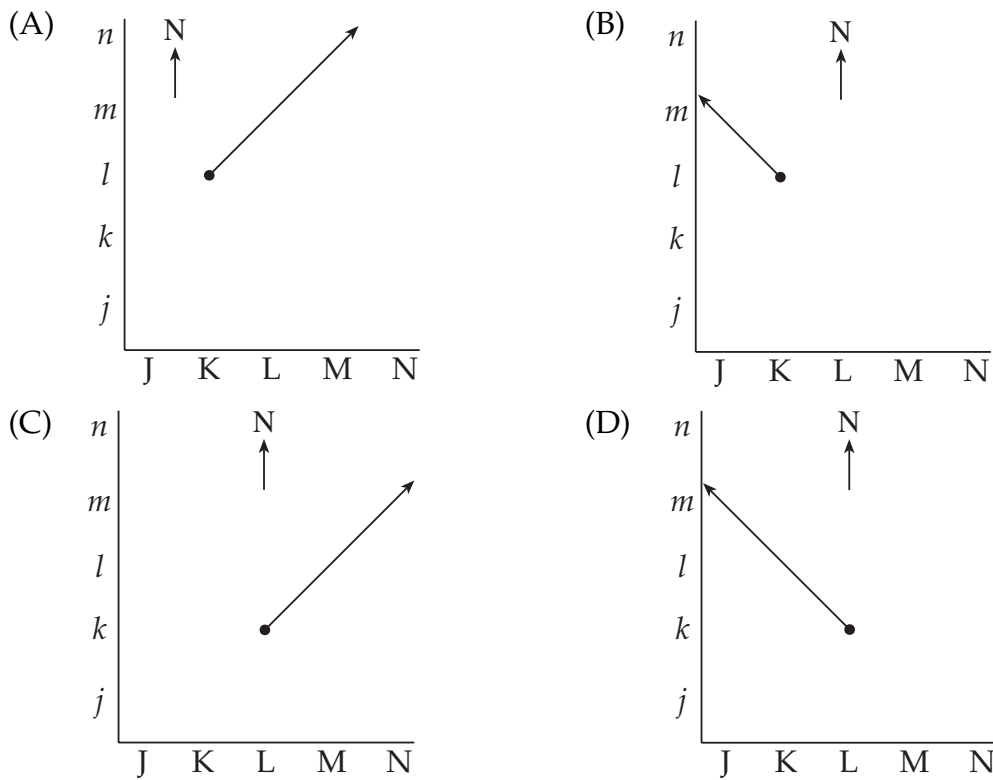

74

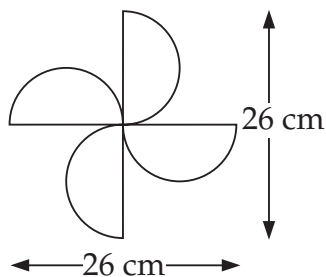

What is the perimeter of this design, to the nearest centimetre?

- (A) 134 cm                      (B) 163 cm                      (C) 186 cm                      (D) 215 cm

- 75 Luke made a rough sketch of an antenna and its support wire.

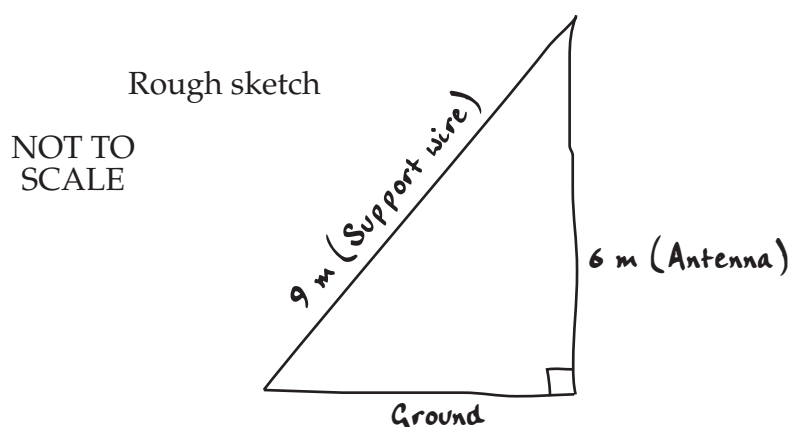

Use a scale drawing or trigonometry to calculate the angle between the support wire and the ground.

What is this angle, to the nearest degree?

- (A)  $34^\circ$                       (B)  $42^\circ$                       (C)  $48^\circ$                       (D)  $56^\circ$

WORKING SPACE

End of Section 2 Part A

Go on to Part B

BLANK PAGE

BLANK PAGE

BLANK PAGE



BOARD OF STUDIES  
NEW SOUTH WALES

**2000  
SCHOOL  
CERTIFICATE  
TEST**

**7 November**

**MATHEMATICS**

**SECTION 2**

**Part B**

**25 marks**

**CENTRE NUMBER**

--	--	--	--	--

**STUDENT NUMBER**

--	--	--	--	--	--	--	--	--	--

**Directions for Section 2 Part B**

- 1 Allow about 30 minutes to answer this part
- 2 Part B Questions 76–84
- 3 Calculators may be used in Section 2
- 4 Write your answers to Questions 76–84 in this booklet
- 5 Complete your answers in either blue or black pen
- 6 Write your Centre Number and Student Number at the top of this page

Questions 76 to 80 are worth 1 mark each. Each question MAY have MORE THAN ONE correct answer. Fill in the response oval(s) completely.

---

**Question 76**

To evaluate  $\frac{(26 + 75) \times 13}{2}$  with a calculator, we could press buttons in the order

(A)  $26 + 75 \times 13 \div 2 =$

(B)  $26 + 75 \div 2 \times 13 =$

(C)  $26 + 75 = \times 13 \div 2 =$

(D)  $26 + 75 = \div 2 \times 13 =$

(A)

(B)

(C)

(D)

---

**Question 77**

'Half of a number is decreased by 5 and the result is 15.'

If the number is  $x$ , this statement could be written as

(A)  $\frac{1}{2}x - 5 = 15.$

(B)  $\frac{1}{2x} - 5 = 15.$

(C)  $\frac{x}{2} - 5 = 15.$

(D)  $\frac{1}{2}(x - 5) = 15.$

(A)

(B)

(C)

(D)

---

**Question 78**

Paulene is shorter than Mona. Ruth is taller than Stamo.

In order of increasing height, they could be

- (A) Ruth, Mona, Stamo, Paulene.
- (B) Stamo, Paulene, Ruth, Mona.
- (C) Paulene, Stamo, Mona, Ruth.
- (D) Stamo, Ruth, Paulene, Mona.

(A)                       (B)                       (C)                       (D)

---

**Question 79**

All edges of a rectangular prism are measured in whole centimetres.

One edge is 10 cm long.

The volume of the prism is  $60 \text{ cm}^3$ .

What could be the area of a cross-section of the prism?

- (A)  $10 \text{ cm}^2$                       (B)  $24 \text{ cm}^2$                       (C)  $30 \text{ cm}^2$                       (D)  $36 \text{ cm}^2$

(A)                       (B)                       (C)                       (D)

---

**Question 80**

A bag contains 64 marbles of different colours.

It is known that there are exactly 32 red marbles and exactly 12 yellow marbles.

A person draws out one marble from the bag.

Which of the following statements could possibly be true?

- (A) The probability of choosing a blue marble is 1.
- (B) The probability of choosing a blue marble is  $\frac{20}{64}$ .
- (C) The probability of choosing a blue marble equals the probability of choosing a red marble.
- (D) The probability of choosing a blue marble equals the probability of choosing a yellow marble.

(A)                       (B)                       (C)                       (D)

---

**End of questions in Section 2 Part B that may require you to fill in more than one correct answer.**

**Please turn over**

---

**Question 81** (5 marks)

The shaded section of this diagram is to be cut to complete the net of a solid.

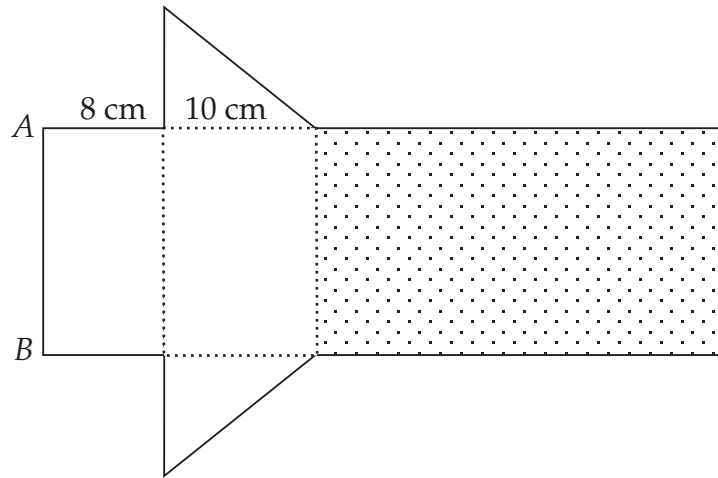

DIAGRAM  
TO  
SCALE

(a) Mark accurately where the shaded section must be cut.

(b) Name the solid that can be formed.

.....

.....

(c) By measurement and calculation, find the length of side  $AB$ .

.....

.....

(d) When assembled, the net folds into a drink container.  
David has 12 litres of juice.

How many of these containers can he fill? (1 litre =  $1000 \text{ cm}^3$ )

.....

.....

.....

.....

.....

.....

**Question 82** (5 marks)

MILLENNIUM MOVIE STUDIOS

<b>Tour Prices</b>	
Adults	\$39
Children (Under 13 years)	\$28
Students (Ages 13–18 years)	\$33
Pensioners	\$27
Family ticket (2 adults, 2 children)	\$115

- (a) (i) Two adults and two children (ages 6 and 10) buy a family ticket.

How much do they save on the normal price?

.....  
 .....

- (ii) Calculate this saving as a percentage of the normal price. Write your answer to one decimal place.

.....  
 .....

- (b) A school is given a quote of \$795 for a group of 30 Year 10 students to visit the studios.

How much will each student save on the normal price?

.....  
 .....

- (c) Two people visit the studios and pay \$61 for their tickets.

What could their ages be?

.....

- (d) When the Goods and Services Tax (GST) is added, tour prices increase by 10%.

What is the new price for a pensioner?

.....



**Question 84** (5 marks)

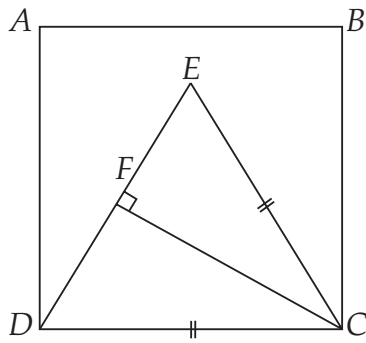

NOT TO SCALE

$ABCD$  is a square.  
 $\triangle DEC$  is an equilateral triangle.  
 Side  $EC = 6$  cm.  
 $CF \perp DE$ .  
 $F$  is the midpoint of  $DE$ .

- (a) Calculate the area of the square  $ABCD$ .

.....

- (b) Use Pythagoras' theorem to show that  $FC = 5.2$  (to 1 decimal place).

.....  
 .....  
 .....

- (c) The line  $GE$  is added to the diagram so that  $GE \perp AB$ .

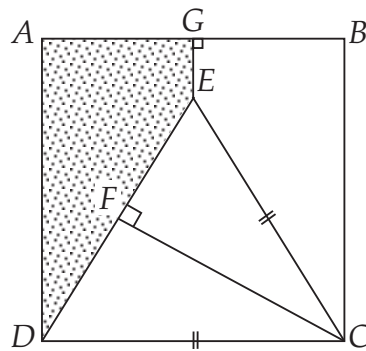

NOT TO SCALE

- (i) Find the length of  $GE$ .

.....  
 .....

- (ii) Calculate the shaded area.

.....  
 .....  
 .....

**End of test**

BLANK PAGE

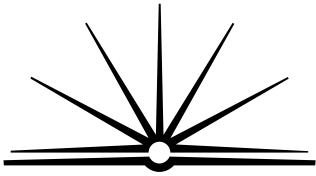

**BOARD OF STUDIES**  
NEW SOUTH WALES

**2000  
SCHOOL  
CERTIFICATE  
TEST**

**7 November**  
Start 9.25 am

**MATHEMATICS**

**SAMPLE  
QUESTIONS  
& FORMULAE  
BOOKLET**

## Instructions for answering questions

- Complete your answers in either blue or black pen.
- ALL answers to questions in Section 1 and Section 2 Part B must be written in the spaces provided in the Section 1 and Section 2 Part B Question and Answer booklets.
- **Completing the diagram**

You may wish to use a pencil for completing the diagram questions.

### Sample 1:

Draw a line through  $C$ , perpendicular to  $AB$ .

*The question has been answered below.*

Label the point of intersection of the two lines,  $M$ .

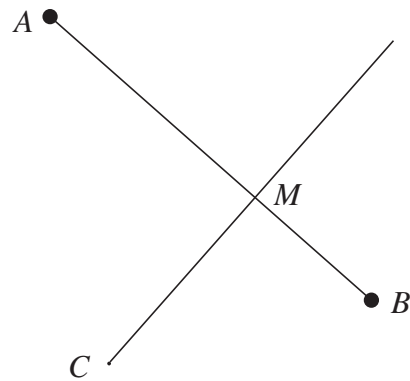
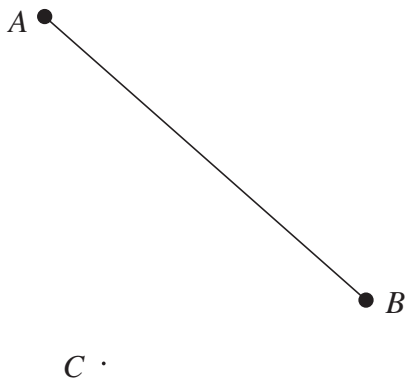

*Line  $CM$  is drawn perpendicular to  $AB$  using a set square or pair of compasses and ruler.*

● **Multiple choice**

Complete your answers to the multiple choice questions (in Section 2 PartA) on the answer sheet provided. Select the alternative A, B, C or D that best answers the question. Fill in the response oval completely.

**Sample 2:**  $2 + 4 =$  (A) 2 (B) 6 (C) 8 (D) 9  
 A  B  C  D

If you think you have made a mistake, put a cross through the incorrect answer and fill in the new answer.

A  B  C  D

If you change your mind and have crossed out what you consider to be the correct answer, then indicate the correct answer by writing the word **correct** and drawing an arrow as follows.

A  B  C  D   
 correct  
 ↙

● **Multiple choice questions that may have more than one correct answer**

Complete your answers to the multiple choice questions that may have more than one correct answer in the Section 2 Part B Question and Answer Booklet.

**Sample 3:**  $\frac{2}{3} =$  (A)  $\frac{2-1}{3-1}$  (B)  $\frac{2+1}{3+1}$  (C)  $\frac{2 \times 1}{3 \times 1}$  (D)  $\frac{2 \div 1}{3 \div 1}$   
 A  B  C  D

*Two oval shapes have been filled in to show the two correct answers.*

If you think you have made a mistake, put a cross through the incorrect answer and fill in the new answer.

If you change your mind and have crossed out what you consider to be the correct answer, then indicate the correct answer by writing the word **correct** and drawing an arrow.

# FORMULAE

For use in SECTION 1 and SECTION 2

Circumference of a circle =  $\pi \times$  diameter

$$[C = \pi d]$$

Area of a circle =  $\pi \times$  radius squared

$$[A = \pi r^2]$$

Area of a parallelogram = base  $\times$  perpendicular height

$$[A = bh]$$

Area of a rhombus = half the product of the diagonals

$$\left[ A = \frac{1}{2}xy \right]$$

Area of a trapezium = half the sum of the parallel sides  $\times$  perpendicular height

$$\left[ A = \left( \frac{a+b}{2} \right) h \right]$$

Volume of a prism = area of cross-section  $\times$  height

$$[V = Ah]$$

Volume of a cylinder =  $\pi \times$  radius squared  $\times$  height

$$[V = \pi r^2 h]$$

Pythagoras' theorem states:

*In a right-angled triangle,*

*the hypotenuse squared = the sum of the squares of the other two sides*

$$[c^2 = a^2 + b^2]$$