



BOARD OF STUDIES
NEW SOUTH WALES

**2000
SCHOOL
CERTIFICATE
TEST**

7 November

MATHEMATICS

SECTION 2

Part A

50 marks

Directions for Section 2 Part A

- 1 You have 90 minutes to answer Section 2 Part A and Section 2 Part B
- 2
 - Part A Questions 26–75
 - Allow about 60 minutes to answer this part
- 3
 - All questions in Part A are multiple choice
 - Each question has only one correct answer
 - Complete your answers to this part on the Answer Sheet
- 4 Calculators may be used in Section 2
- 5 Complete your answers in either blue or black pen

Complete your answers to Questions 26–75 on the Section 2 Part A—Answer Sheet.

26 Calculate $\frac{53.7}{1.9 + 2.7}$ correct to 1 decimal place.

- (A) 11.6 (B) 11.7 (C) 30.9 (D) 31.0
-

27 $5x - 7y + 3x + y =$

- (A) $2x - 6y$ (B) $2x - 8y$ (C) $8x - 6y$ (D) $8x - 8y$
-

28 Which of these solids has a volume different from the others?

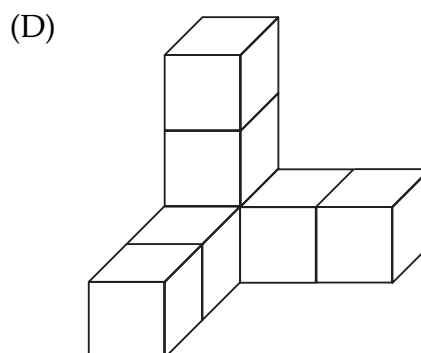
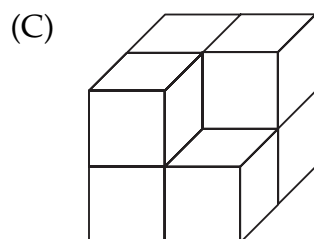
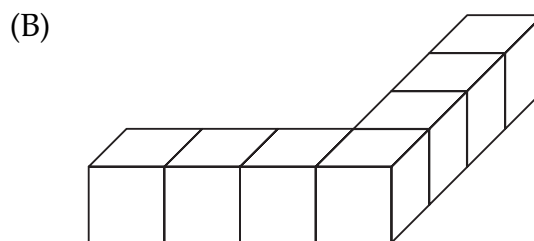
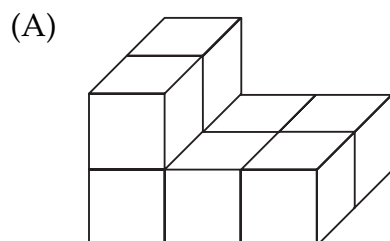

29 A compact disc player is marked at \$120.
A retailer offers a 15% discount.

Calculate the discounted price.

- (A) \$18 (B) \$102 (C) \$105 (D) \$112
-

30 4.7 kg is equivalent to

- (A) 0.0047 t (B) 0.047 g (C) 0.47 t (D) 470 g
-

31 Which of these solids is a prism?

(A)

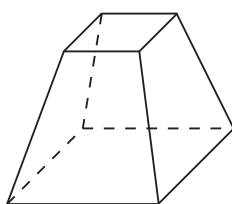

(B)

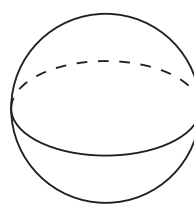

(C)

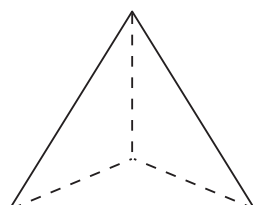

(D)

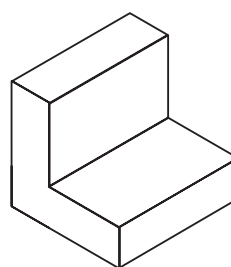

32 A recipe for hummus includes 300 g chick peas and 2 tablespoons of sesame seeds. These quantities make 4 servings.

Anji uses 3 tablespoons of sesame seeds.

Which statement is correct?

- (A) She needs 400 g chick peas and can make 5 servings.
- (B) She needs 450 g chick peas and can make 5 servings.
- (C) She needs 400 g chick peas and can make 6 servings.
- (D) She needs 450 g chick peas and can make 6 servings.

33 Stephanie took 36 photos on a roll of film.
When the film was developed only 27 photos were printed.

What percentage of photos were NOT printed?

- (A) 9%
 - (B) 25%
 - (C) 33%
 - (D) 75%
-

34 Which two rectangles are similar?

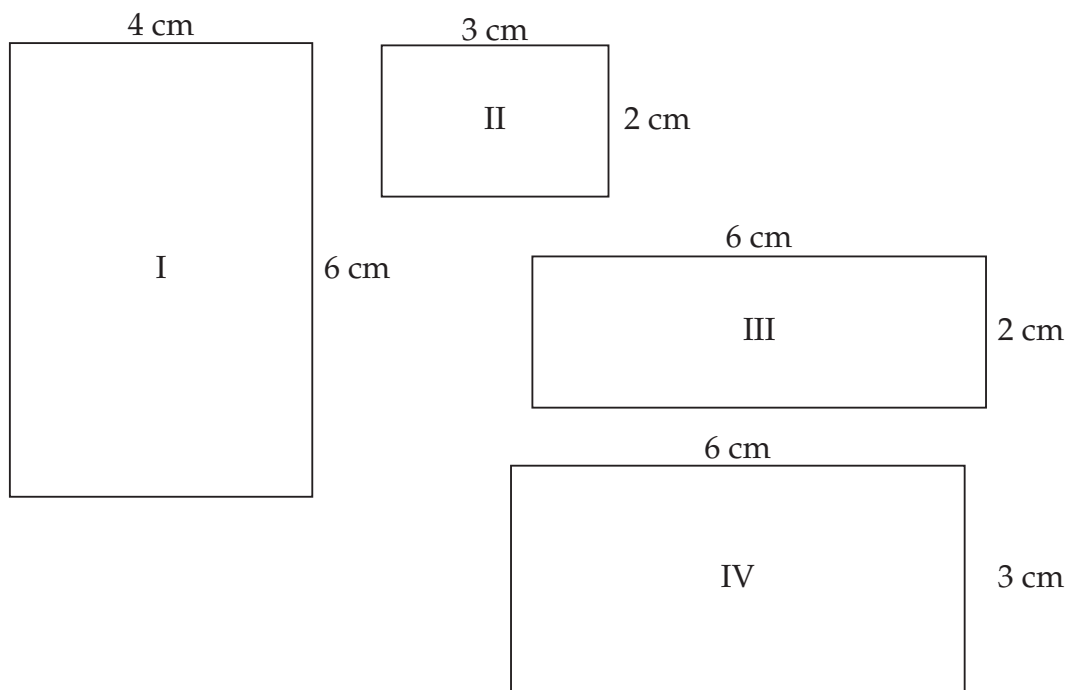

- (A) I and II (B) II and III (C) III and IV (D) I and IV

35

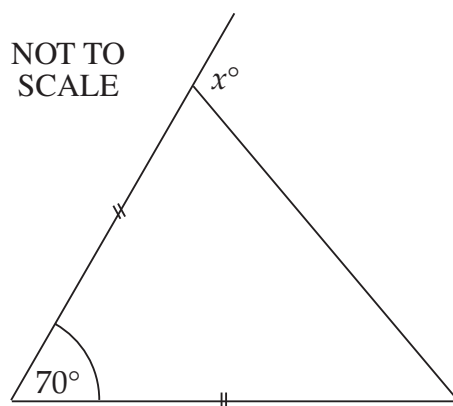

What is the value of x ?

- (A) 55 (B) 110 (C) 125 (D) 140

36 Three times are given:

7.48 pm;

25 minutes to 8 in the evening;

1940 (24 hour time).

What is the correct order, from earliest to latest of these times?

- (A) 1940; 7.48 pm; 25 minutes to 8 in the evening.
(B) 25 minutes to 8 in the evening; 7.48 pm; 1940.
(C) 1940; 25 minutes to 8 in the evening; 7.48 pm.
(D) 25 minutes to 8 in the evening; 1940; 7.48 pm.

37

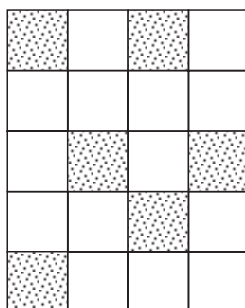

What percentage of this rectangle has been shaded?

- (A) 6% (B) 30% (C) 43% (D) 70%

38 You are considering a part-time job.

Which would pay the most?

- (A) 4 hours at triple rate.
(B) 6 hours at the normal rate and 3 hours at double time.
(C) 7 hours at the normal rate and 4 hours at time-and-a-half.
(D) We cannot say unless the normal rate is known.

39 The statement ' $90 + 185 = 275$ ' illustrates the claim
'a right angle plus a reflex angle can equal a reflex angle'.

Which statement illustrates the claim
'an acute angle plus an obtuse angle can equal a reflex angle'?

- (A) $30 + 165 = 195$ (B) $50 + 125 = 175$
(C) $75 + 180 = 255$ (D) $95 + 170 = 265$

40 When viewed from above, which of these solids has a different TOP VIEW from the others?

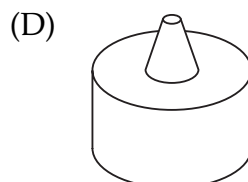
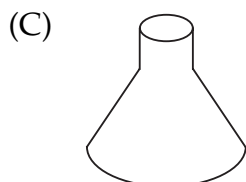
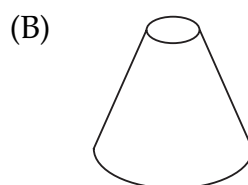
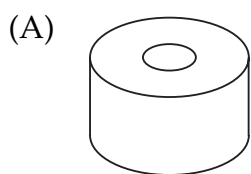

41 Which of the following lemonade prices represents the best value for money?

(A) 390 mL for \$0.25

(B) 500 mL for \$0.33

(C) 1.25 L for \$0.75

(D) 2 L for \$1.25

42 Which of the following *both* appear in this diagram?

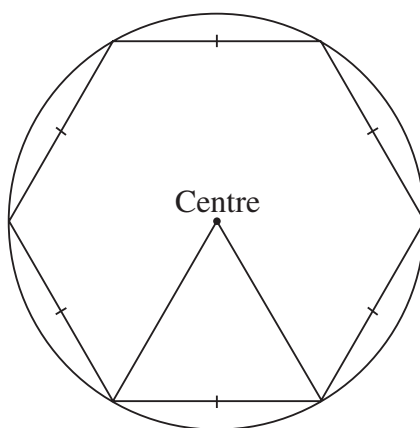

(A) Radius, tangent

(B) Diameter, equilateral triangle

(C) Arc, quadrant

(D) Chord, hexagon

43 Which operations are needed to find the value of a , if $a^2 + 64 = 100$?

(A) Subtract 64 then find the square root.

(B) Subtract 64 then divide by 2.

(C) Add 64 then find the square root.

(D) Add 64 then divide by 2.

44 Which expression does NOT equal $2a$?

- (A) $a \times a$ (B) $2 \times a$ (C) $3a - a$ (D) $a + a$

45

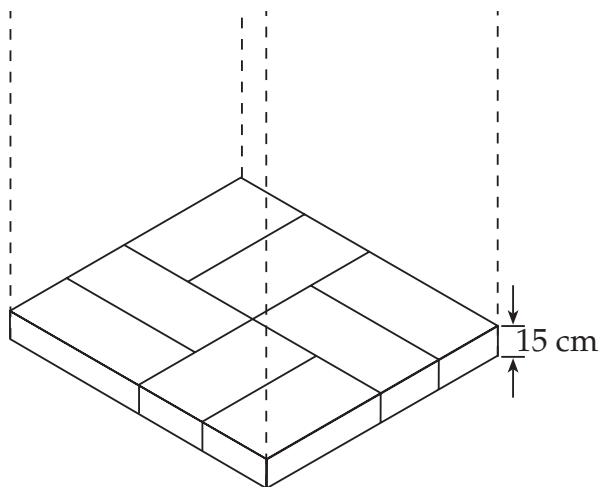

Mr Lee wishes to construct a stack of bricks 3 metres high.

Each layer is to be like the pattern shown in the diagram.

The thickness of one layer of bricks is 15 cm.

How many bricks does he need for the stack?

- (A) 20 (B) 40 (C) 120 (D) 160

46

<i>Stem</i>	<i>Leaf</i>			
1	3	4	6	
2	4	5	5	6
3	2	7	7	9
4	3	4	6	

There are 2 modes for the data presented in the stem-and-leaf diagram.

What are the modes?

- (A) 4 and 6 (B) 5 and 7 (C) 26 and 32 (D) 25 and 37

47 The average weight of 10 people is 74 kg.

If 4 of them weigh 80 kg each, what is the average weight of the remaining 6 people?

- (A) 42 kg (B) 68 kg (C) 70 kg (D) 77 kg

48 Which figure has exactly TWO axes of symmetry?

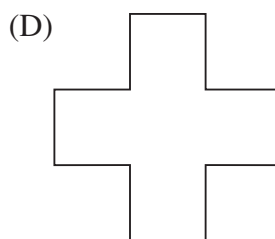
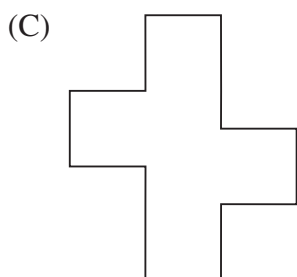
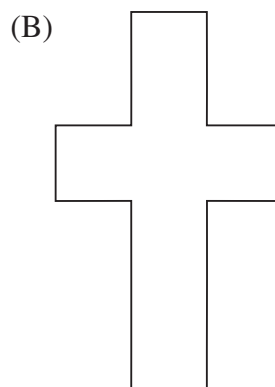
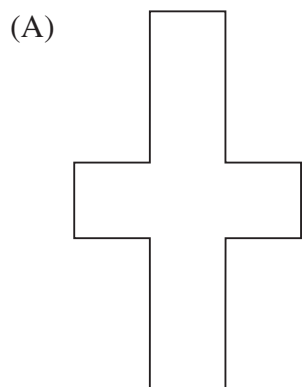

49 When it is 12.00 noon in Sydney it is 10.00 am in Perth.
Zac leaves Sydney at 1.00 pm and flies to Perth.
The flight takes 5 hours.

What time is it in Perth when he arrives?

- (A) 3.00 pm (B) 4.00 pm (C) 6.00 pm (D) 8.00 pm

50 An amount of \$55 000 is to be divided amongst three friends, Chris, Ted and Gloria, in the ratio 3 : 5 : 3.

How much does Ted receive?

- (A) \$5 000 (B) \$11 000 (C) \$15 000 (D) \$25 000
-

51

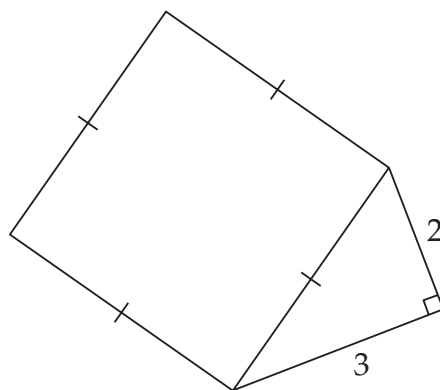

Calculate the area of the square.

- (A) $\sqrt{5}$ units² (B) $\sqrt{13}$ units² (C) 13 units² (D) 25 units²

52

x	-2	-1	0	1	2
y	-2	0	2	4	6

What is the correct rule for this table?

- (A) $y = 2x + 2$ (B) $y = x + 4$ (C) $y = x + 2$ (D) $y = 2x - 2$

53

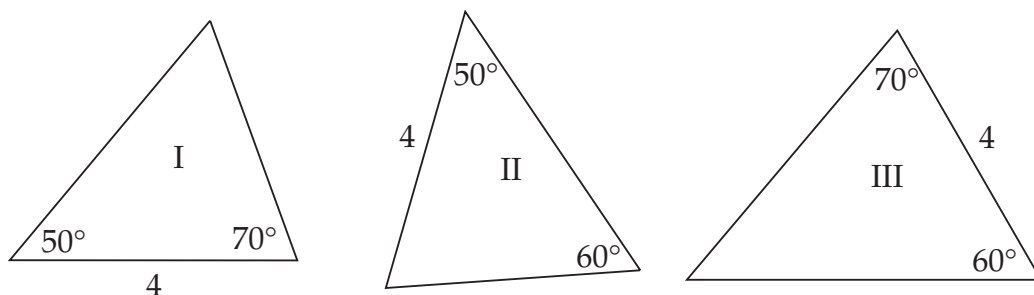

Which triangles are congruent?

- (A) I and II only (B) I and III only
 (C) II and III only (D) I, II and III

54 Nikki wants to record a television program starting at 9.55 am and finishing at 2.17 pm.

How long is the program?

- (A) 3 hours and 22 minutes (B) 4 hours and 22 minutes
 (C) 5 hours and 22 minutes (D) 7 hours and 38 minutes

55

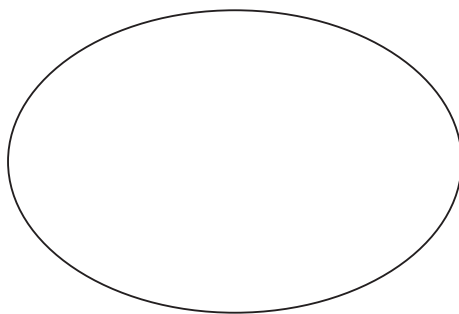

Give the best estimate for the area of this shape.

- (A) 12 cm^2 (B) 18 cm^2 (C) 24 cm^2 (D) 28 cm^2

56

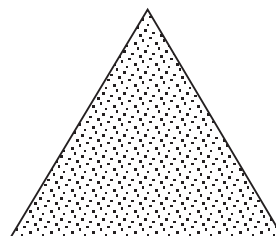
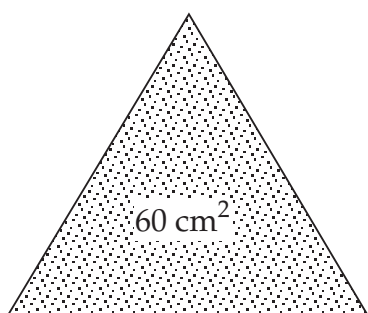

NOT TO
SCALE

The ratio of the areas of the triangles is 3 : 2.
The area of the larger triangle is 60 cm^2 .

What is the area of the smaller triangle?

- (A) 24 cm^2 (B) 36 cm^2 (C) 40 cm^2 (D) 48 cm^2

57 Solve the equation $2a + 4 = 48$.

- (A) $a = 8$ (B) $a = 20$ (C) $a = 22$ (D) $a = 26$

58 You are given the mean of 20 scores.

Which of the following can you calculate?

- (A) The median of the scores
(B) The range of the scores
(C) The mode of the scores
(D) The sum of the scores

59



A satellite is launched from the Earth. At a certain height, it begins to orbit the Earth. The dotted line shows the path of the satellite.

Which graph best shows the distance of the satellite from the Earth, from the time it is launched?

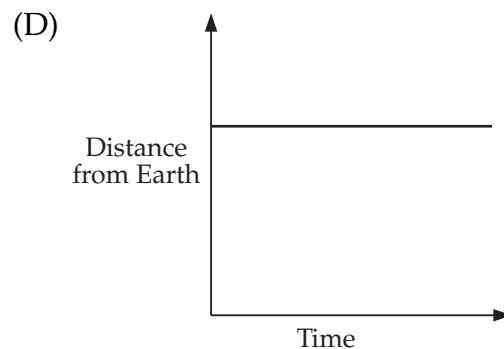
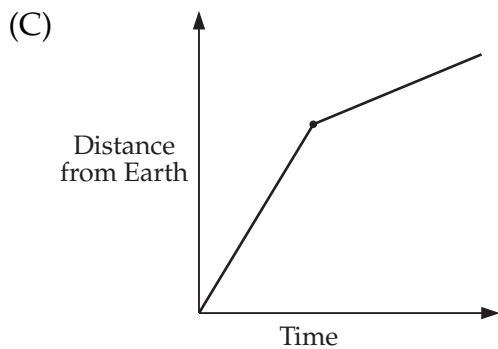
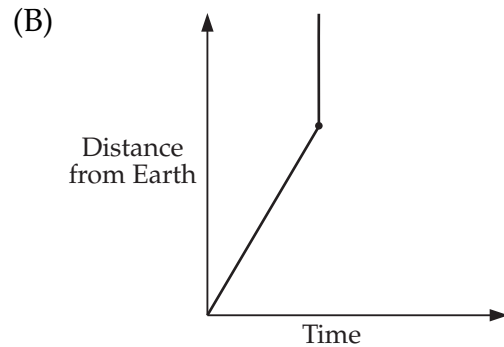
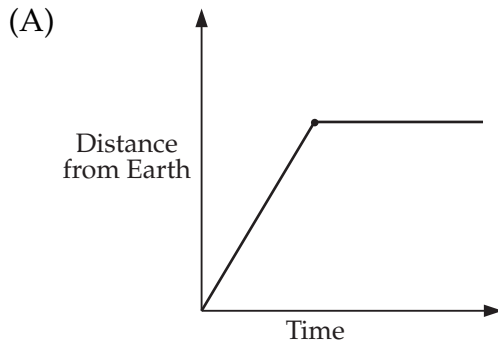

60 Tracey fills her car with 28 litres of petrol at 82.3 cents per litre.

How much change does she get from a \$50 note (to the nearest 5 cents)?

- (A) \$16.00 (B) \$23.05 (C) \$26.95 (D) \$34.00

61 In optics, the formula $M = \frac{f}{f-d}$ is used where

M = magnification, f = focal length, d = distance from lens.

Find M if $f = 10$ and $d = 8$.

- (A) -7 (B) 0.2 (C) 5 (D) 8

62

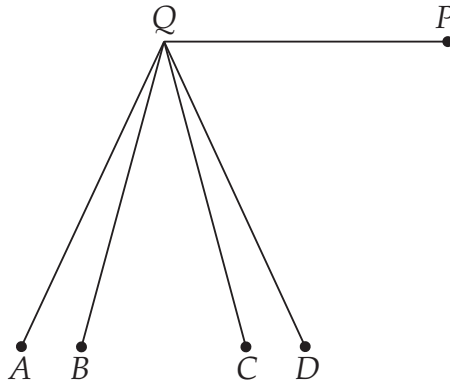

QP is one arm of a reflex angle measuring 255° .

Which is the other arm of the angle?

- (A) QA (B) QB (C) QC (D) QD

63

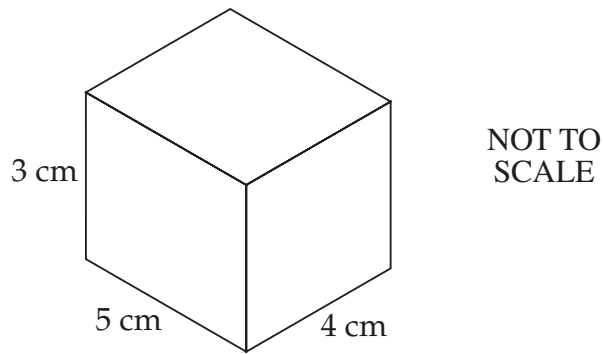

Calculate the surface area of the rectangular prism.

- (A) 47 cm^2 (B) 60 cm^2 (C) 90 cm^2 (D) 94 cm^2

64 A pipe has an inner radius of 6 cm and an outer radius of 12 cm.

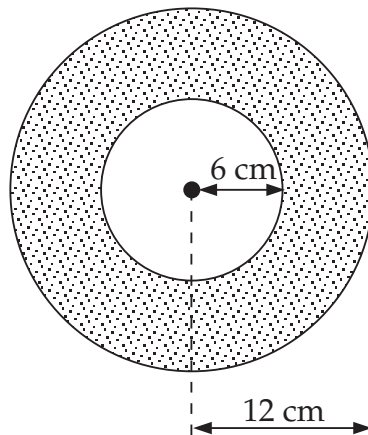

The shaded area in square centimetres is given by

- (A) 12π . (B) 36π . (C) 108π . (D) 144π .

65

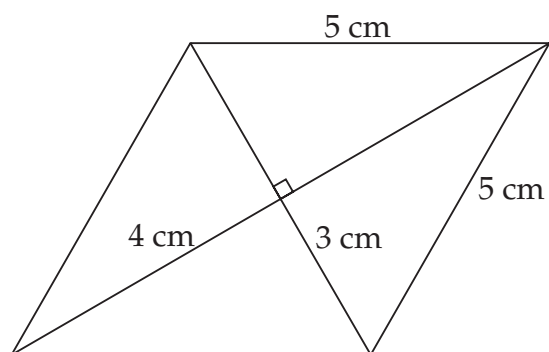

NOT TO SCALE

Calculate the area of the rhombus.

- (A) 12 cm^2 (B) 24 cm^2 (C) 25 cm^2 (D) 48 cm^2

66 Elizabeth has begun to bisect the interval PQ .

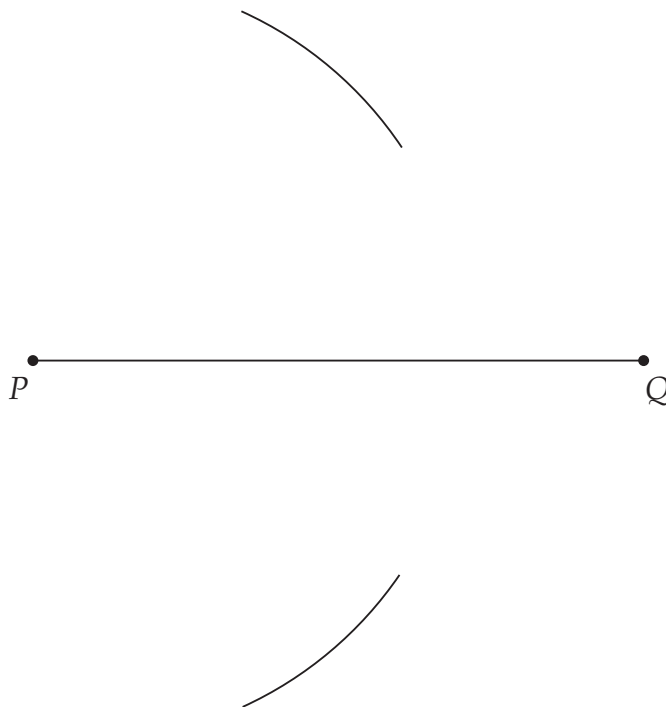

The next three steps, in the *wrong order* are

- 1 Join RT .
- 2 Draw arcs to cut the previous arcs at R and T .
- 3 Put the point of the pair of compasses on Q .

The *correct order* for the steps is

- (A) 3, 2, 1. (B) 2, 1, 3. (C) 2, 3, 1. (D) 3, 1, 2.

67 The circumference of a circular field is 628 m.

A smaller circular field has a radius of 50 m.

Cathy runs $1\frac{1}{2}$ laps around the larger field.

How many laps of the smaller field must she complete to run the same distance?

- (A) 2 (B) 3 (C) 4 (D) 5

68

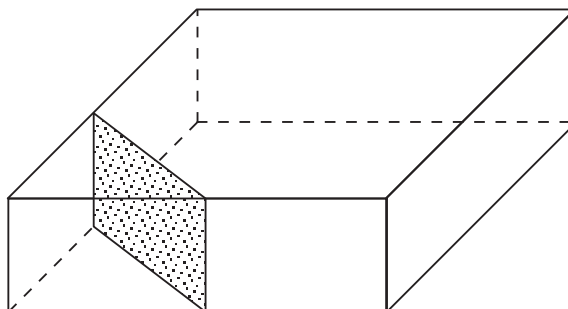

The shaded area shows where a rectangular prism has been cut to form two new solids.

Name these two solids.

- (A) triangular pyramid and hexagonal prism
 (B) triangular pyramid and pentagonal prism
 (C) triangular prism and hexagonal prism
 (D) triangular prism and pentagonal prism

69

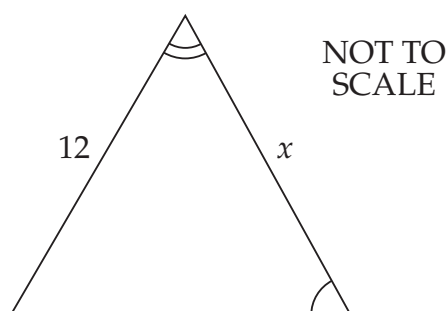
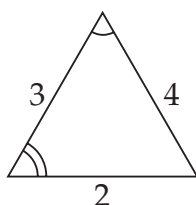

What is the value of x ?

- (A) 9 (B) 16 (C) 18 (D) 24

70

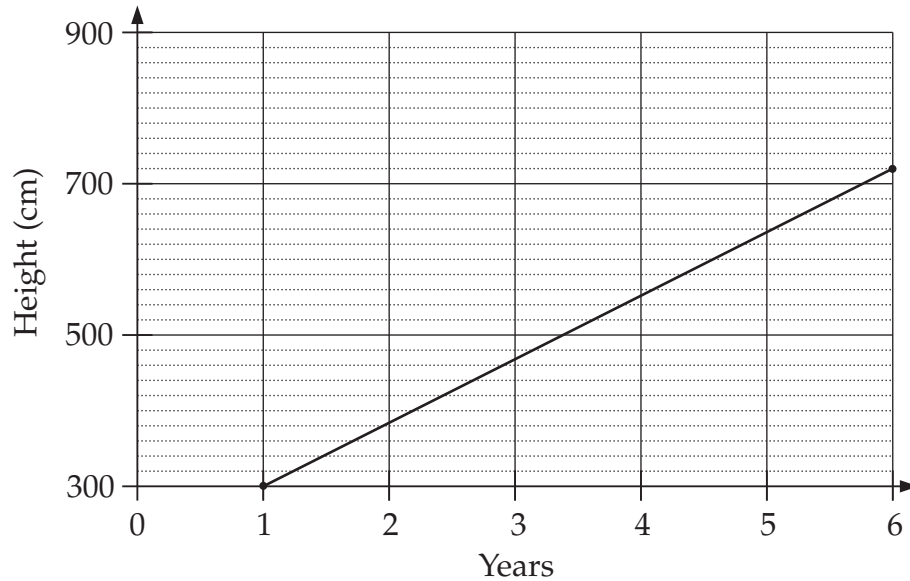

The graph shows the increase in height of a tree over a number of years. Calculate the rate of increase in centimetres per year.

- (A) 70 (B) 84 (C) 120 (D) 144

71 The timeline shows some major events.

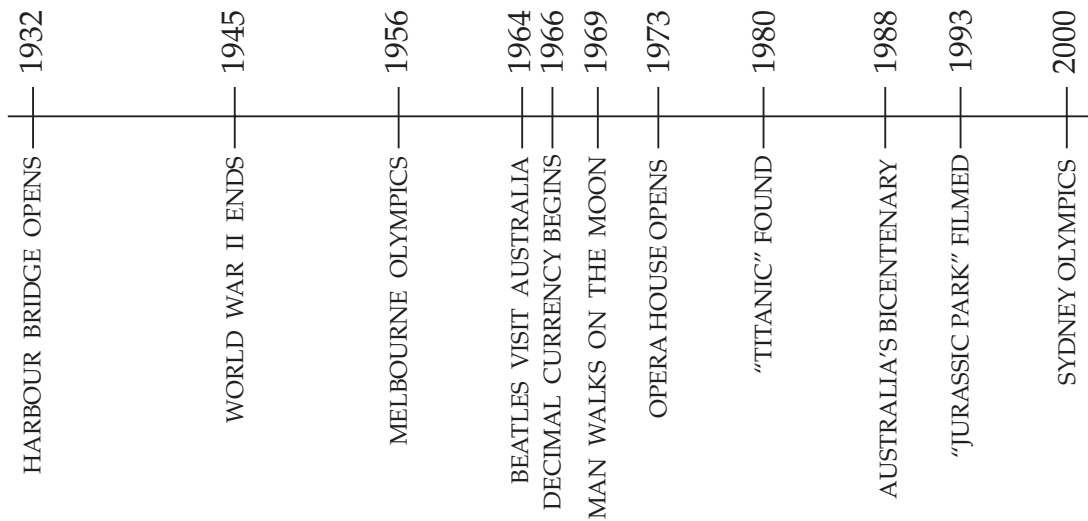

Which event occurred half-way between the opening of the Harbour Bridge and the Sydney Olympics?

- (A) Beatles visit Australia
 (B) Man walks on the moon
 (C) Decimal currency begins
 (D) Opera House opens

72

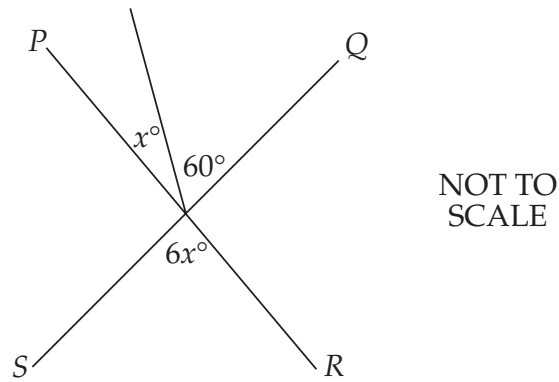

PR and QS are straight lines.

Find the value of x .

- (A) 10 (B) 12 (C) 15 (D) 30

73 Which diagram shows a road running north-west from position Lk?

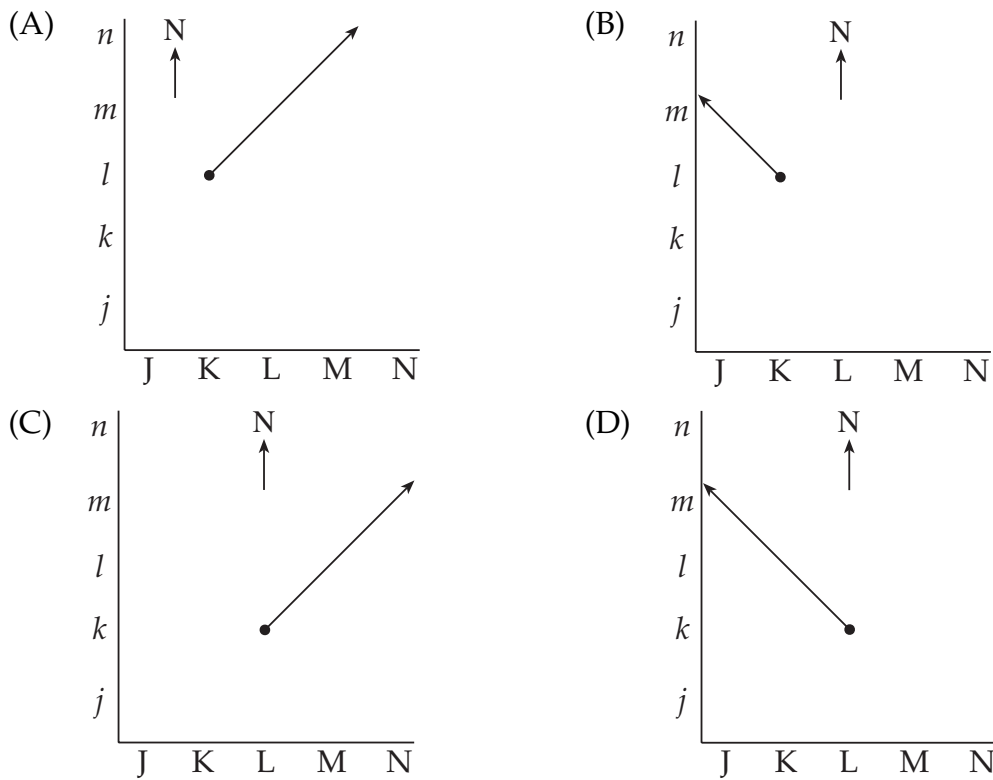

74

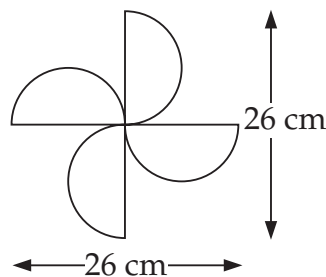

What is the perimeter of this design, to the nearest centimetre?

- (A) 134 cm (B) 163 cm (C) 186 cm (D) 215 cm

- 75 Luke made a rough sketch of an antenna and its support wire.

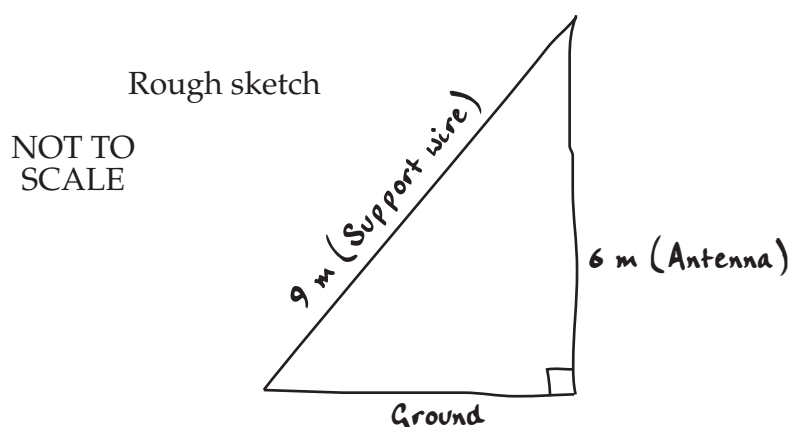

Use a scale drawing or trigonometry to calculate the angle between the support wire and the ground.

What is this angle, to the nearest degree?

- (A) 34° (B) 42° (C) 48° (D) 56°

WORKING SPACE

End of Section 2 Part A

Go on to Part B

BLANK PAGE

BLANK PAGE

BLANK PAGE