



BOARD OF STUDIES
NEW SOUTH WALES

**2002
SCHOOL
CERTIFICATE
TEST**

12 November

MATHEMATICS

SECTION 1

25 marks

CENTRE NUMBER

--	--	--	--	--

STUDENT NUMBER

--	--	--	--	--	--	--	--	--	--

Directions for Section 1

- You have 30 minutes to answer this section
- Write your answers to Questions 1–25 in this booklet
- Calculators are NOT to be used in this section
- Write your Centre Number and Student Number at the top of this page

Complete your answers to Questions 1–25 in this booklet.

1 Evaluate $9 - 3.74$

.....
.....

2

BEEF ROLLS
\$3.50 each
10% extra on Sundays

How much is a beef roll on Sunday?

.....
.....

3 When $8.\square 57$ is rounded to 1 decimal place the answer is 8.5.

What number should be written in the \square ?

.....
.....

- 4 Use the divided bar graph to complete the frequency table.

Year 10 Mathematics grades

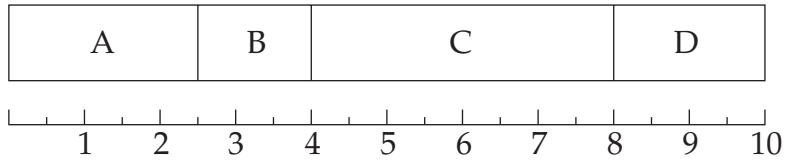

<i>Grade</i>	<i>Frequency</i>
A	30
B	18
C	<input type="text"/>
D	24

- 5 Evaluate $(2\frac{1}{2})^2$

.....

- 6 The design on a piece of fabric has stars and circles in the ratio 4 : 3.

Explain the meaning of the underlined words.

.....

- 7 The temperature in a freezer was -4°C . During a 3 hour power failure, the temperature in the freezer increased by $1\frac{1}{2}^{\circ}\text{C/h}$.

What was the temperature in the freezer at the end of the power failure?

.....

8

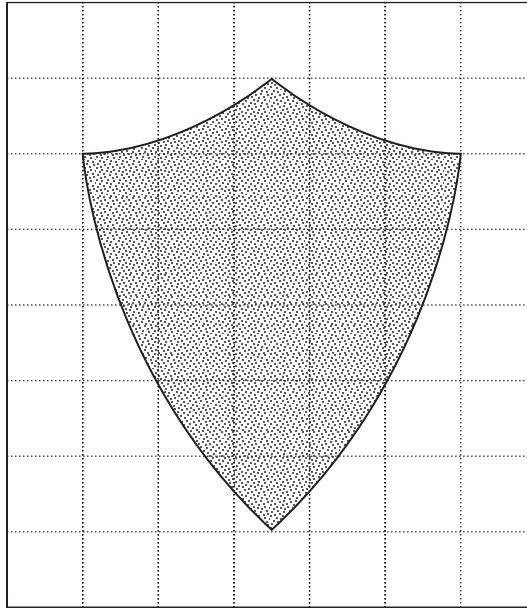

Estimate the shaded area in square centimetres.

.....

9 Two of the operations $+$, $-$, \times , \div have been left out of this number sentence.

$$8 \square 6 \square 3 = 6$$

Insert an operation in each square to make the sentence true.

10 Solve $2p - 3 = 8$

.....

11 Lucia uses 20 litres of petrol to drive 250 kilometres.

Express this rate in litres per 100 kilometres.

.....

12

$$\frac{\triangle}{3 \times \square} > 2$$

Place whole numbers less than 10 in \triangle and \square to make the statement true.

13 Sketch the view of this solid when viewed from the top.

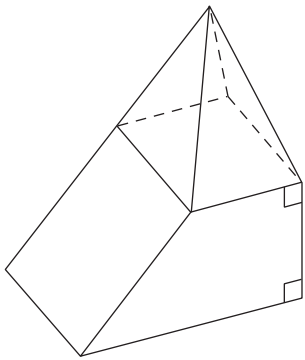
	<p>ANSWER</p>
--	---------------

14 Narelle is paid an allowance of 25 cents per kilometre to drive to and from work. She lives 17 km from work and works 4 days a week.

Calculate her allowance for one week.

.....

.....

15 The *median* of the data shown in this stem-and-leaf plot is 116.

Stem	Leaf
10	1, 3, 7, 8
11	2, \square , 7, 8, 9
12	0, 4, 8

What is the value of \square ?

.....

.....

- 16 This figure is made up of a rectangle and a semi-circle.

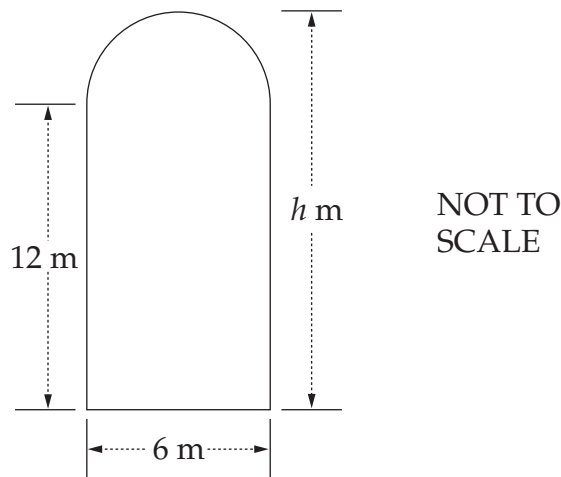

Calculate the value of h .

.....

- 17 Dieter's grandmother was 42 years old when Dieter was born. His grandmother was three times his age when she retired.

How old was Dieter when his grandmother retired?

.....

18 $\sqrt{\square^2 + 12^2} = 13$

Write a number in the square to make this a true statement.

19

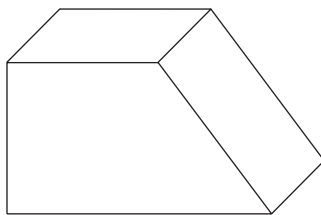

Draw ALL lines to complete the net of the prism.

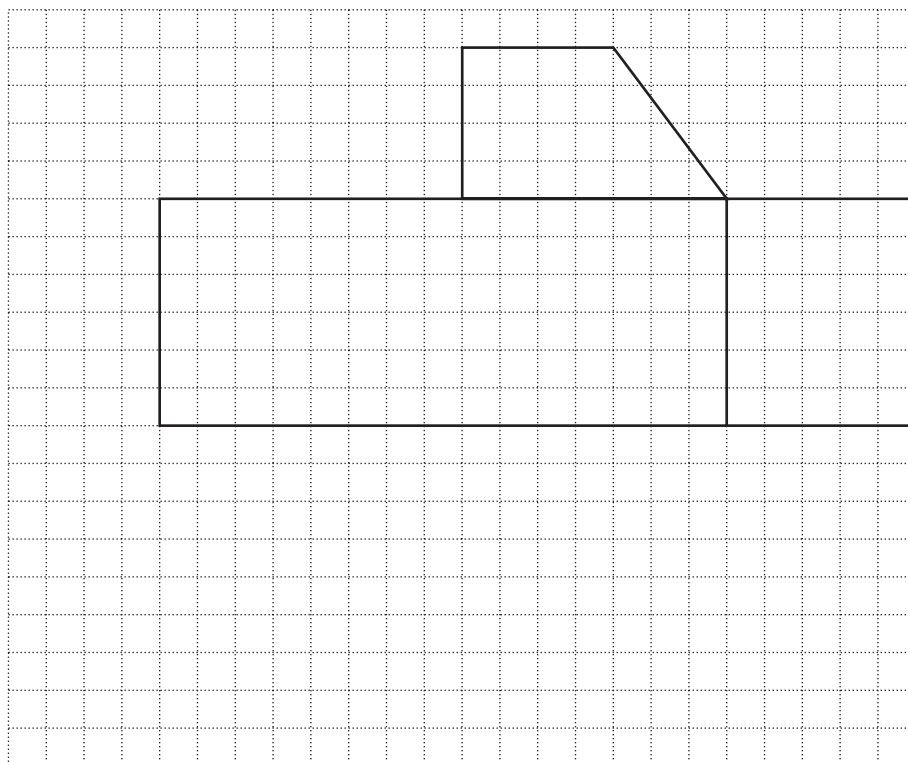

20 Consider the pattern.

$$5^3 - 4^3 = 5^2 + 5 \times 4 + 4^2 = 61$$

$$6^3 - 5^3 = 6^2 + 6 \times 5 + 5^2 = 91$$

$$7^3 - 6^3 = 7^2 + 7 \times 6 + 6^2 = 127$$

Using this pattern, complete:

$$10^3 - 9^3 = \square + \square \times \square + \square = 271$$

- 21 The average weight of 5 pumpkins was 2.4 kg. When 1 pumpkin was sold, the average weight of the remaining pumpkins was 2.5 kg.

How heavy was the pumpkin that was sold?

.....

.....

- 22 Peter has a bag that contains a total of 12 marbles. Some are red and some are blue. Peter took a marble out of the bag at random, recorded its colour, then put it back into the bag before he took another marble. He did this 20 times.

This table shows his results.

<i>Colour</i>	<i>Number of times</i>
Blue	
Red	
Total	20

What is the most likely number of red marbles in Peter's bag?

.....

.....

23

Prism I

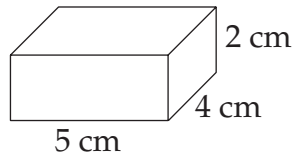

Prism II

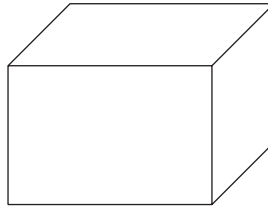

NOT TO SCALE

The volume of Prism II is four times the volume of Prism I.

What could be the dimensions of Prism II?

Length = cm

Breadth = cm

Height = cm

24 George went fishing. He recorded his catch on a bar graph but forgot to label it.



He caught twice as many *flathead* as *breem*.

He also caught some *tailor* and 2 *snapper*.

How many *tailor* did he catch?

.....

Please turn over

- 25 Pirates have buried treasure on Lone Palm Island.
The treasure is south-west of the cave.
Its distance from the palm tree is the same as its distance from the cave.
The positions of the palm tree and the cave are marked with dots.
The cave is due north of the palm tree.

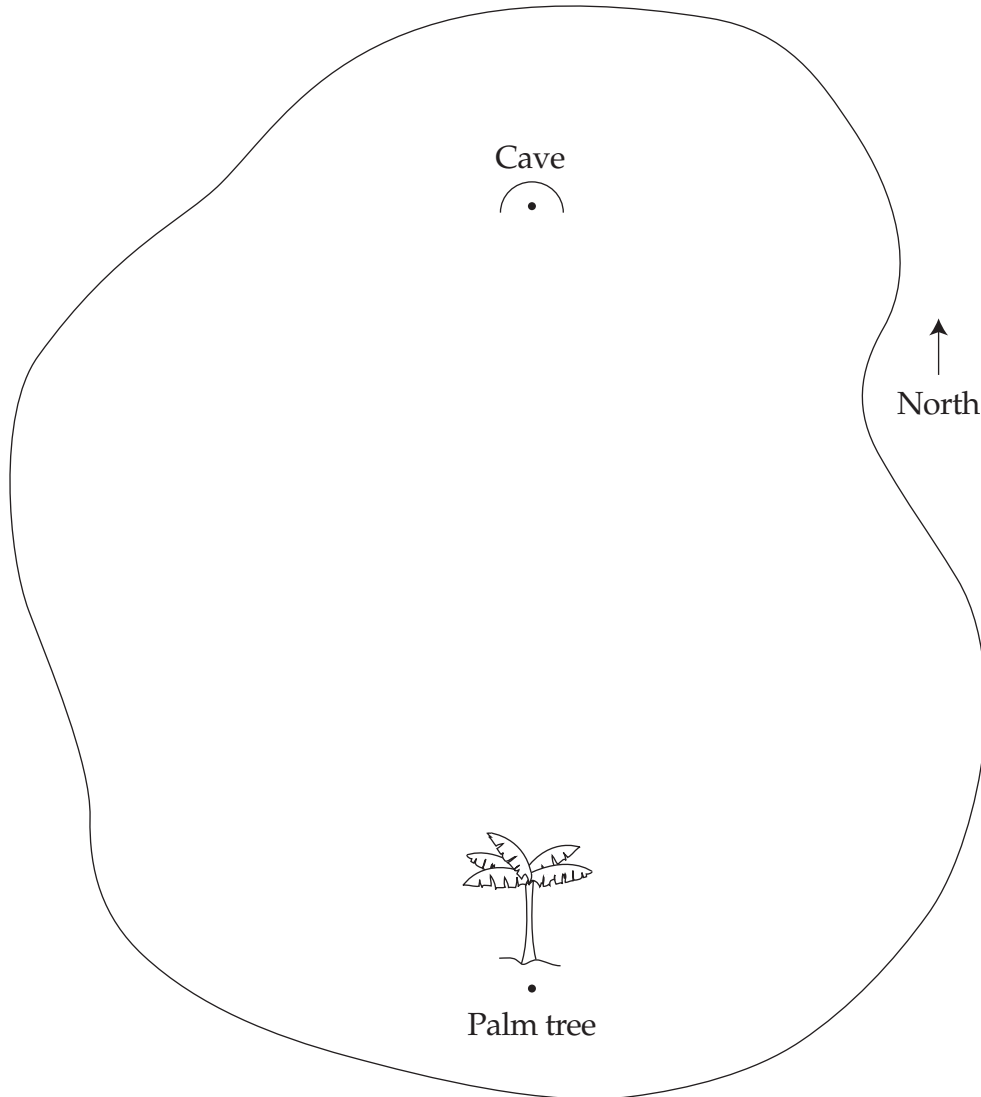

Use your geometrical instruments to locate the treasure. Mark the spot with an X.

End of Section 1

BLANK PAGE

BLANK PAGE



BOARD OF STUDIES
NEW SOUTH WALES

**2002
SCHOOL
CERTIFICATE
TEST**

12 November

MATHEMATICS

**SECTION 2
Part A
50 marks**

Directions for Section 2

- You have 90 minutes to answer Section 2 Part A and Section 2 Part B
- Calculators may be used in Section 2

Directions for Part A

- Allow about 60 minutes to answer Part A
- All questions in this part are multiple choice
- Each question has only ONE correct answer
- Complete your answers to Questions 26–75 on the answer sheet provided

Complete your answers to Questions 26–75 on the Section 2 Part A—Answer Sheet.

26 Convert 0.875 km to metres.

- (A) 8.75 m (B) 87.5 m (C) 875 m (D) 8750 m

27

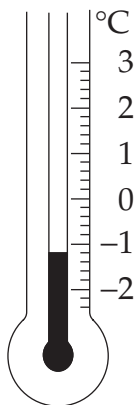

What temperature is shown on this thermometer?

- (A) -1.1°C (B) -1.2°C (C) -2.4°C (D) -2.8°C

28 Which expression is NOT equal to $4m$?

- (A) $m \times m \times m \times m$ (B) $6m - 2m$
(C) $\frac{8m}{2}$ (D) $m + m + m + m$

29

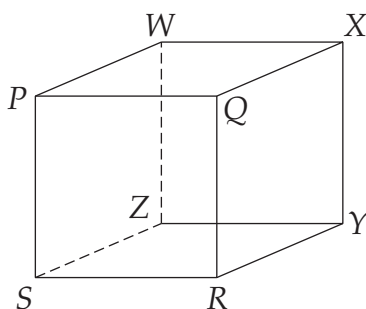

Which line is skew to PS ?

- (A) PX (B) XS (C) XY (D) QX

30 Which triangle, when correctly drawn to scale, will contain a right angle?

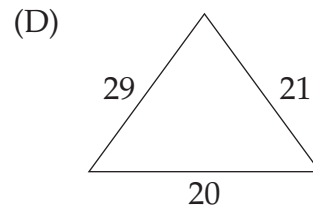
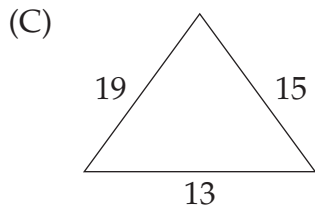
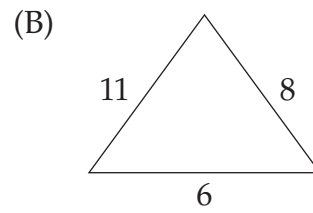
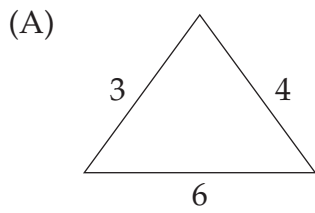

31 Which of these events has the highest probability?

- (A) Tossing a head on a coin.
- (B) Rolling a two on a normal die.
- (C) Choosing Monday at random from the days of the week.
- (D) Randomly choosing an e from the vowels a, e, i, o and u .

32 The formula $A = \frac{h}{2}(a + b)$ can be used to find the area of a trapezium, where a and b are the parallel sides and h is the perpendicular height between them. For a certain figure, Tim measures $a = 6$ and $h = 4$.

Which figure is Tim using?

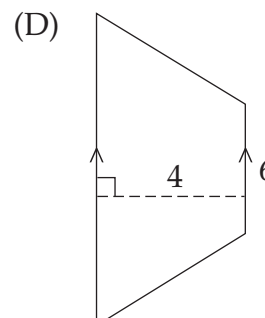
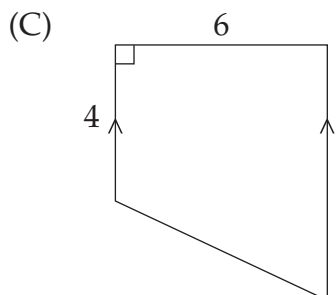
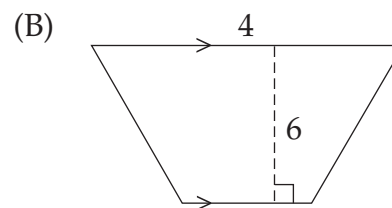
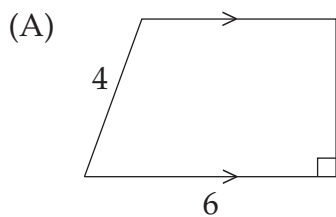

33 Simplify $5x - 4 + 2x - 1$

(A) $7x - 5$

(B) $7x + 5$

(C) $7x - 3$

(D) $7x + 3$

34

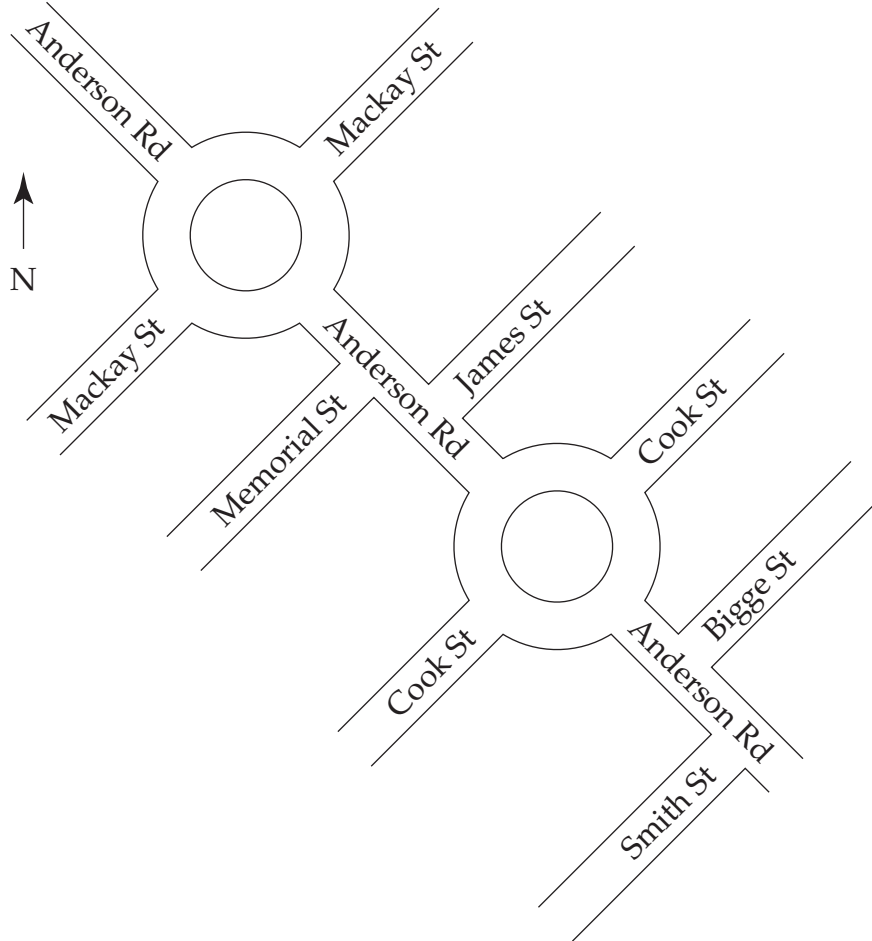

Brian is travelling south-east along Anderson Road. He turns left at the first street after the Cook Street roundabout.

Into which street does he turn?

(A) Bigge

(B) James

(C) Memorial

(D) Smith

- 35 Equal numbers of teenage boys and girls were interviewed regarding their recreational interests.

This table was compiled.

	<i>Boys</i>	<i>Girls</i>
Watching TV or videos (past two weeks)	97%	97%
Playing electronic or computer games (past two weeks)	79%	58%
Organised sport (past year)	66%	52%
Organised cultural activities (past year)	20%	40%

What percentage of teenagers attended 'Organised cultural activities' in the past year?

- (A) 20% (B) 30% (C) 40% (D) 60%
-

- 36 Sabrina bought a dress that was reduced in price to \$76.

Which piece of information would NOT be sufficient to calculate the money she saved off the normal price?

- (A) The amount of GST, at 10%, included in the normal price
(B) Per cent discount
(C) Normal price
(D) Change Sabrina received from \$100
-

- 37 Naomi used a picture graph to record the sale of television sets in her shop. She chose the following symbol to represent 6 television sets.

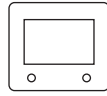

Which diagram best represents the sale of 28 television sets?

- (A)
- (B)
- (C)
- (D)

- 38 The volume of a rectangular prism can be found using the formula $V = l \times b \times h$.

Find the value of l given that $V = 240$, $b = 3$, $h = 5$.

- (A) 16 (B) 48 (C) 80 (D) 400

- 39

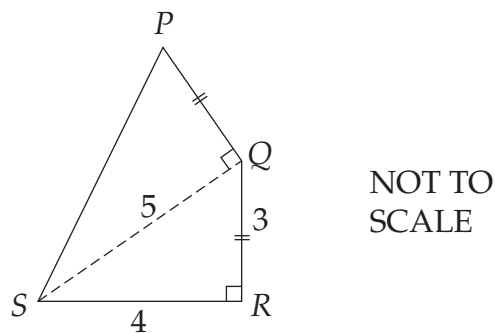

What is the perimeter of the quadrilateral $PQRS$, to the nearest whole number?

- (A) 14 (B) 15 (C) 16 (D) 21

- 40 A bicycle wheel of 700 mm diameter has 36 spokes.

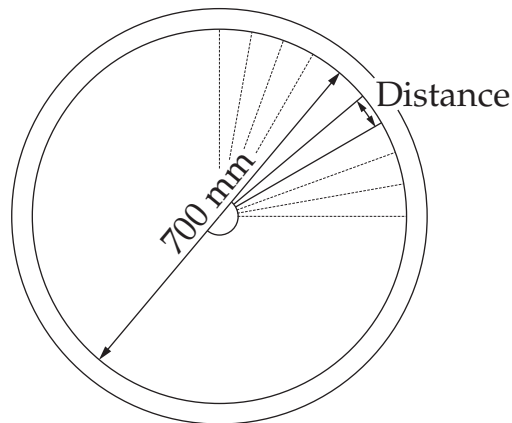

What is the approximate distance between the spokes along the rim?

- (A) 2 cm (B) 6 cm (C) 12 cm (D) 19 cm
-

- 41 Huong is a builder's labourer and is paid \$16.50 per hour. He is also paid a 'remote site' allowance of \$3.75 per hour.

Calculate his wage when he worked 38 hours, of which 7 hours were at a remote site.

- (A) \$537.75 (B) \$627 (C) \$653.25 (D) \$769.50
-

- 42 Amy's wage increased by 50%. Her new wage is \$480 per week.

What was her former wage?

- (A) \$240 (B) \$320 (C) \$430 (D) \$720
-

- 43

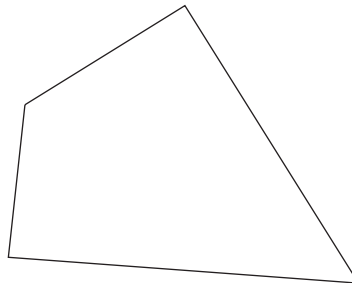

How many axes of symmetry does this quadrilateral have?

- (A) 0 (B) 1 (C) 2 (D) 4
-

- 44 The formula for converting a temperature from degrees Fahrenheit ($^{\circ}\text{F}$) to degrees Celsius ($^{\circ}\text{C}$) is

$$C = \frac{5}{9}(F - 32)$$

where F = temperature in degrees Fahrenheit

C = temperature in degrees Celsius.

Max needs to store some food in a refrigerator at a temperature between 0°C and 4°C .

Which temperature in degrees Fahrenheit would be suitable?

- (A) 30°F (B) 36°F (C) 40°F (D) 44°F

45

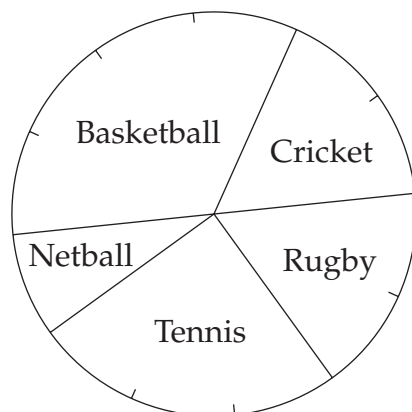

A group of 240 students was asked to choose their favourite sport. The results were shown on a sector graph.

How many chose the most popular sport?

- (A) 48 (B) 72 (C) 80 (D) 120

- 46 A cyclist can ride one lap of an oval in 40 seconds.

How many laps will he have completed after riding for 6 minutes at the same speed?

- (A) 6 (B) 7 (C) 9 (D) 15

- 47 Noela lives at Herman. She must travel by bus and then train to reach Combee by noon.

Bus Timetable				
	am	am	am	am
Herman	11:04	11:07	11:11	11:17
Biased Bay	11:09	11:12	11:16	11:22
Southtown station	11:18	11:21	11:26	11:31

Train Timetable				
	am	am	am	am
Southtown	10:58	11:06	11:25	11:36
Moss Point	11:00	11:08	11:27	
Greenpoint	11:12	11:20	11:39	11:50
Flamingo	11:23	11:31		12:01
Strathlare		11:35	11:55	12:05
Combee	11:31	11:38	11:58	12:08

What is the latest time she could catch a bus at Herman?

- (A) 11:04 (B) 11:07 (C) 11:11 (D) 11:17

- 48 This dot plot shows the number of children in 20 families.

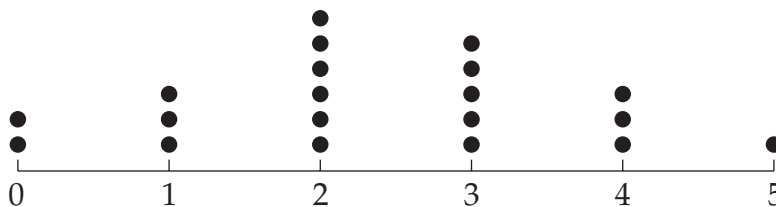

What percentage of families have 3 or more children?

- (A) 20% (B) 25% (C) 45% (D) 55%

- 49 On 12 October 2002, Kylie found a packet of biscuits with a use-by date of 25 September 2002.

How many days past the use-by date are the biscuits?

- (A) 13 (B) 14 (C) 17 (D) 18

- 50 A drink and a bag of lollies cost \$1.30. Two drinks and a bag of lollies cost \$2.10.

Which of the following could be bought with \$5?

- (A) 1 drink and 8 bags of lollies
(B) 2 drinks and 7 bags of lollies
(C) 3 drinks and 6 bags of lollies
(D) 4 drinks and 4 bags of lollies

- 51 Sue, Jim, Keryn and Peta cycle to school. This graph represents their journeys.

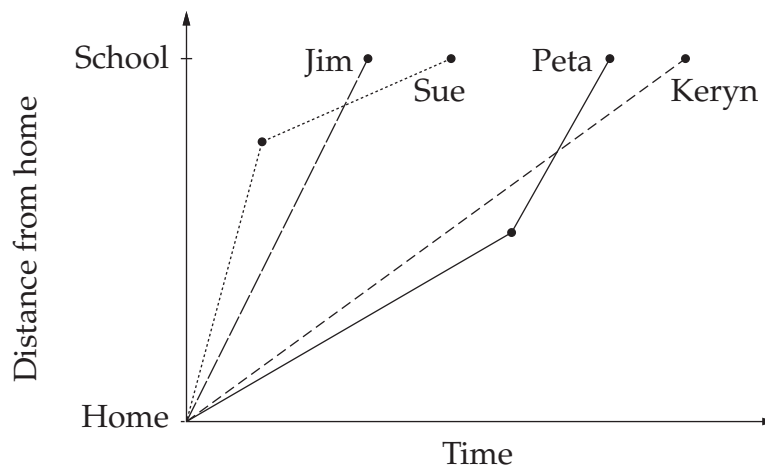

Who has the highest average speed?

- (A) Sue (B) Jim (C) Keryn (D) Peta

- 52 Which of the following expressions has a value of 3?

- (A) 3^0 (B) $\frac{4}{12}$
(C) $3 + 3 + 3 \div 3$ (D) $3^3 \div 3^2$

- 53 Jill bought a container of chlorine for her swimming pool.

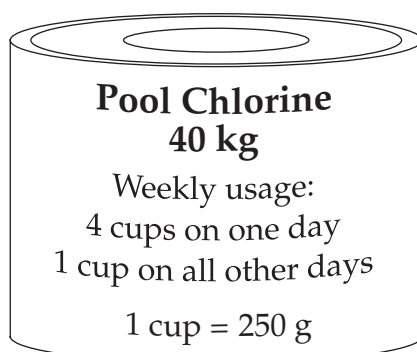

How many weeks should one container last?

- (A) 15 (B) 16 (C) 28 (D) 32
-

- 54 Which two words complete this statement correctly?

In _____ quadrilaterals, the _____ sides and angles are equal.

- (A) similar, matching (B) similar, opposite
(C) congruent, opposite (D) congruent, matching
-

- 55 A rectangular yard contains a square garden. The rest of the yard is paved.

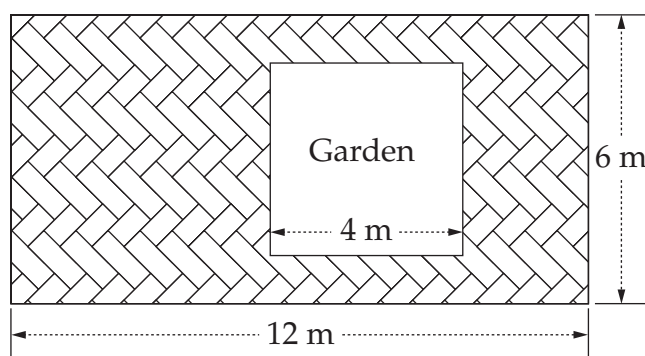

What is the ratio of the garden to the paved area?

- (A) 2 : 7 (B) 2 : 9 (C) 7 : 2 (D) 9 : 2
-

- 56 Dick threw a die 4 times. His scores were 4, 3, 1, 2.

After one more throw of the die, his mean could be

- (A) 2 (B) 2.5 (C) 3.2 (D) 4

57

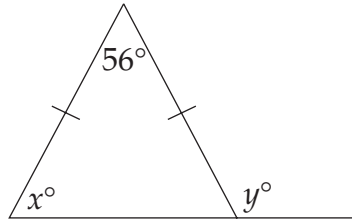

What are the values of x and y ?

- (A) $x = 62$, $y = 118$ (B) $x = 62$, $y = 124$
(C) $x = 56$, $y = 118$ (D) $x = 56$, $y = 124$
- 58 This flag contains two similar rectangles. The longer side of each rectangle is horizontal.

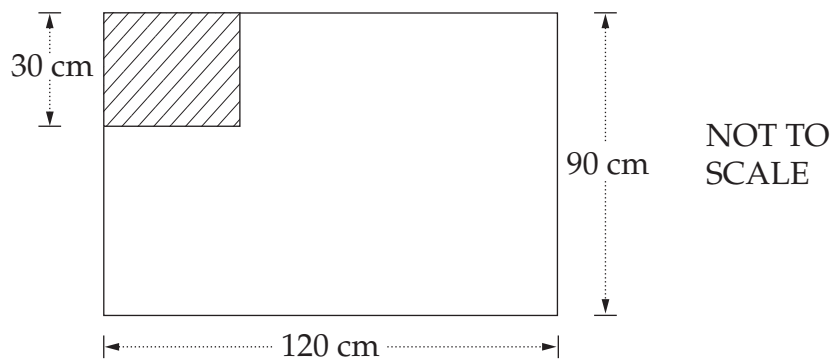

What is the length of the small rectangle?

- (A) 22.5 cm (B) 37.5 cm (C) 40 cm (D) 60 cm

59

Toys sold at Christmas

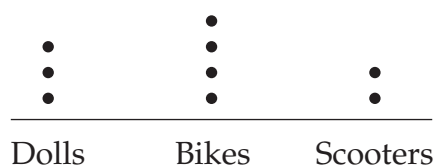

Jarrold decided to represent the information in this dot plot on a sector graph.

What is the sector angle for bikes?

- (A) 40° (B) 80° (C) 120° (D) 160°

60 Peter and Diane have three sons. Diane would like to have a daughter.

If they have another baby, how likely is it to be a girl?

- (A) Close to 50/50, a probability of about $\frac{1}{2}$.
(B) Unlikely, about 1 in 4.
(C) Quite likely, because four boys in a row is unlikely.
(D) Very likely, a probability of about $\frac{3}{4}$.

61

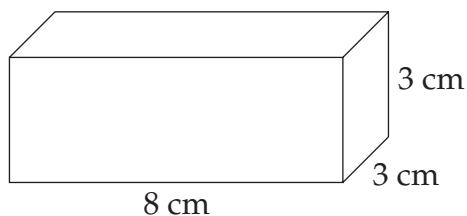

Calculate the surface area of the rectangular prism.

- (A) 57 cm^2 (B) 72 cm^2 (C) 96 cm^2 (D) 114 cm^2

62

Currency conversions

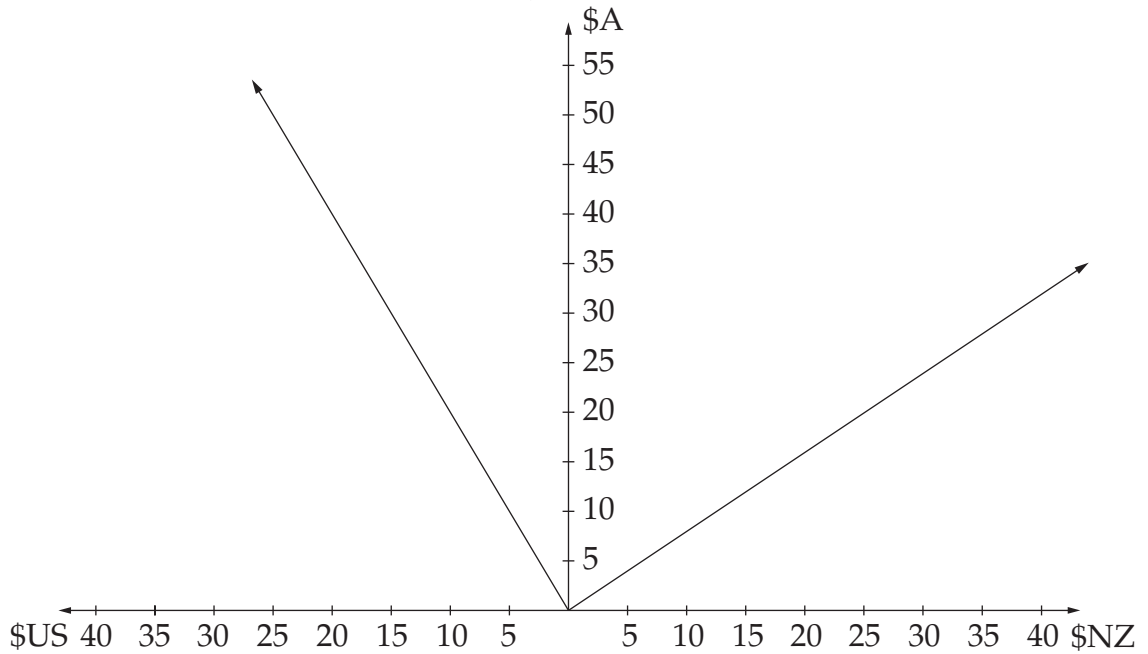

Salma has been on holiday to the United States of America and New Zealand. Salma returns to Australia with \$NZ25 which she converts to \$A.

How much does she get in \$A?

- (A) \$10 (B) \$20 (C) \$31 (D) \$50

63

28 cm Square Grill Pan

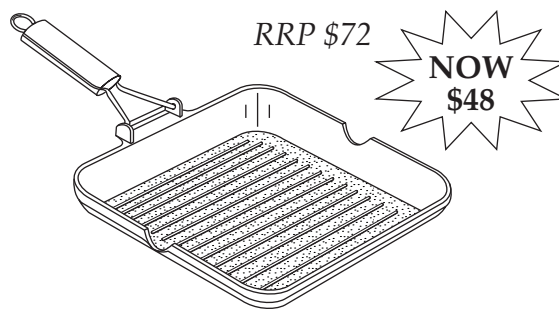

What is the percentage discount on the recommended retail price (RRP)?

- (A) 24% (B) $33\frac{1}{3}\%$ (C) 50% (D) $66\frac{2}{3}\%$

- 64 A dripping tap takes 30 hours to fill a 10 litre watering can. One millilitre contains 15 drops.

At what rate, in drops/second, is the tap dripping?

- (A) 1.4 (B) 5 (C) 20 (D) 41.7

- 65 This tile pattern is made up of 2 squares and 5 rectangles. The dimensions of each rectangle are 6 cm by 3 cm.

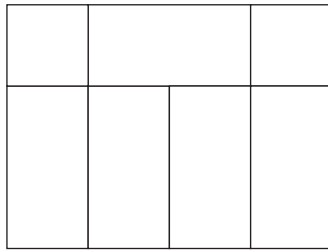

Calculate the area of the pattern shown.

- (A) 18 cm^2 (B) 81 cm^2 (C) 108 cm^2 (D) 144 cm^2

- 66 Anna divided each side of a rectangle into 4 equal parts. She removed a triangle from each corner as shown.

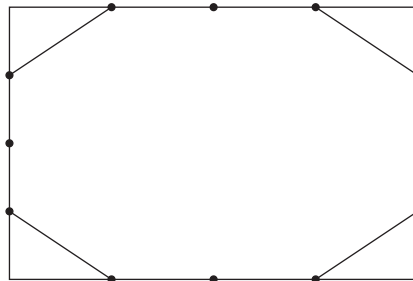

What fraction of the rectangle did she remove?

- (A) $\frac{1}{4}$ (B) $\frac{1}{8}$ (C) $\frac{1}{16}$ (D) $\frac{1}{32}$

- 67 The population of a town at the beginning of 2002 was 80 000. Each year the population increases by 5% of the population at the beginning of that year.

What will the population be at the beginning of 2004?

- (A) 84 000 (B) 88 000 (C) 88 200 (D) 96 000

- 68 The table shows the points on the graph.

a	0	1	2
b	2	4	6

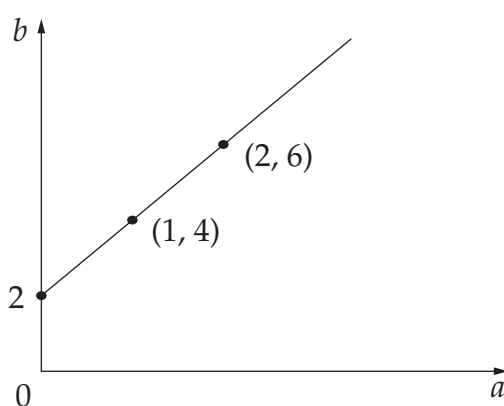

What is the rule that describes this graph?

- (A) $a = 2b$ (B) $a = 2b + 2$ (C) $b = 2a$ (D) $b = 2a + 2$
- 69 In a dice game, players can predict whether the sum of the two numbers on the dice is less than 7, more than 7, or exactly 7.

This table shows the results of 600 trials.

<i>Less than 7</i>	<i>More than 7</i>	<i>Exactly 7</i>
210	270	120

From the table, what is the probability that on the next roll of the dice, the sum of the numbers will NOT be exactly 7?

- (A) 0.2 (B) 0.35 (C) 0.45 (D) 0.8

- 70 The shaded area in the diagram is an annulus. The formula for finding the area of an annulus is: $\text{Area} = \pi(R^2 - r^2)$.

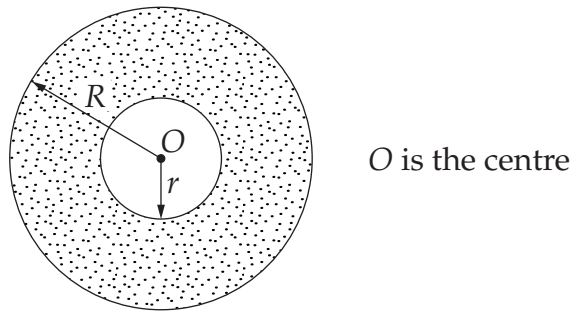

Find the area of an annulus when $R = 10$ m and $r = 7$ m.

- (A) 18.8 m^2 (B) 28.3 m^2 (C) 160.2 m^2 (D) 265.2 m^2

- 71 Maryann graphed the ages and salaries of ten people.

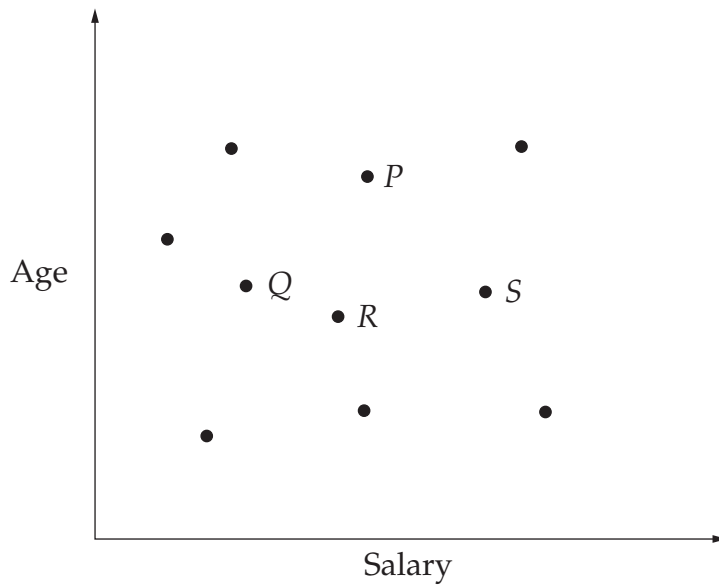

Andrew is close to the median age and earns a higher salary than most of the others surveyed.

Which point represents Andrew?

- (A) P (B) Q (C) R (D) S

- 72 Five days each week Mr Chipps travels to and from work on the airport bus.

City to Sydney airport bus fares

<i>Airport Express costs</i>	<i>Adult</i>	<i>Child</i>	<i>Family</i>
Return fare	\$12.00	\$6.00	\$30.00
One-Way fare	\$7.00	\$3.50	\$17.50
One-Way Inter-terminal	\$3.00	\$1.50	\$7.50
Airport-Ten (ten one-way trips between the airport and the city)	\$55.00	N/A	N/A

How much does Mr Chipps save per day when he purchases an Airport-Ten ticket rather than a return fare?

- (A) \$1 (B) \$3 (C) \$5 (D) \$43

- 73 The circumference of a circle (c) is about three times the diameter (d).

Which graph illustrates this fact?

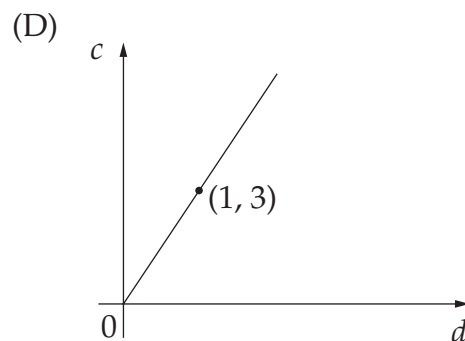
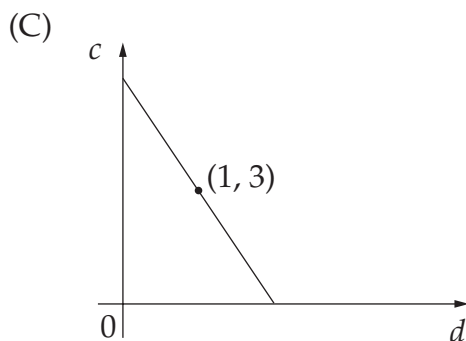
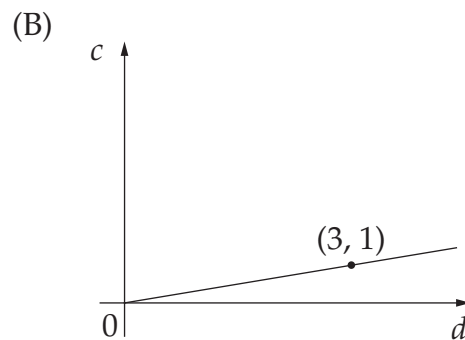
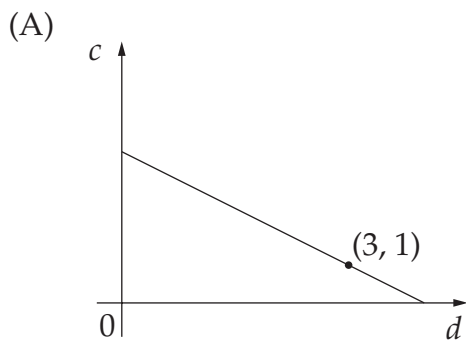

74

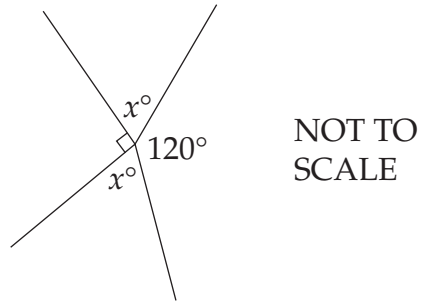

Find the value of x .

- (A) 60 (B) 75 (C) 105 (D) 150
-

- 75 Adam earns \$5 for the first hour of babysitting and \$4 per hour after that. He babysat for n hours.

Which expression represents the amount Adam earned?

- (A) $9n$ (B) $4n + 1$ (C) $4n + 5$ (D) $5n - 1$
-

End of Section 2 Part A

Go on to Part B

BLANK PAGE



BOARD OF STUDIES
NEW SOUTH WALES

**2002
SCHOOL
CERTIFICATE
TEST**

12 November

MATHEMATICS

SECTION 2

Part B

25 marks

CENTRE NUMBER

--	--	--	--	--

STUDENT NUMBER

--	--	--	--	--	--	--	--	--	--

Directions for Section 2 Part B

- Allow about 30 minutes to answer Part B
- Write your answers to Questions 76–84 in this booklet
- Calculators may be used in Part B
- Write your Centre Number and Student Number at the top of this page

Questions 76 to 80 are worth 1 mark each. Each question MAY have MORE THAN ONE correct answer. Fill in the response oval(s) completely.

Question 76

The sum of x and y is 12.

Which of the following statements are true?

- (A) $xy = 12$ (B) $x = 12 - y$ (C) $y = 12 - x$ (D) $x + y = 12$

- (A) (B) (C) (D)

Question 77

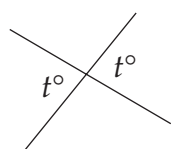

Vertically opposite angles

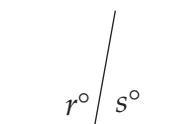

Angles on a straight line
($r + s = 180$)

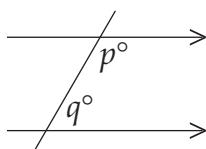

Co-interior angles
($p + q = 180$)

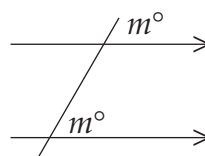

Corresponding angles

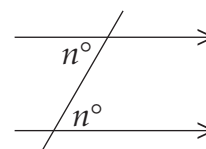

Alternate angles

Daniel uses the information above to correctly deduce that $x = 120$ in the diagram below.

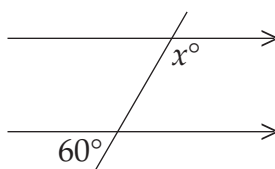

Which two pieces of information are sufficient for Daniel to get his answer?

- (A) Angles on a straight line and corresponding angles
 (B) Angles on a straight line and alternate angles
 (C) Vertically opposite angles and corresponding angles
 (D) Vertically opposite angles and co-interior angles

- (A) (B) (C) (D)

Marks

Question 81 (5 marks)

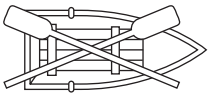

Bert's Boatshed

Hire charges
 \$15 first hour
 then \$10 every hour
 (or part thereof)



BOATS 4U

Hire charges
 \$12 per hour
 (or part thereof)

Hannah hired a boat from Bert's Boatshed from 8.15 am to 4.30 pm.

- (a) For how long did Hannah hire the boat? Give your answer in hours and minutes. **1**

.....

.....

- (b) Complete the table for the cost to hire a boat from Bert's Boatshed. **1**

<i>Time (h)</i>	1	2	3
<i>Cost to hire (\$)</i>			

- (c) How much was Hannah charged for hiring the boat from Bert's Boatshed? **1**

.....

.....

Marks

Question 81 (continued)

(d) Complete the graph for hire charges at Boats 4U.

1

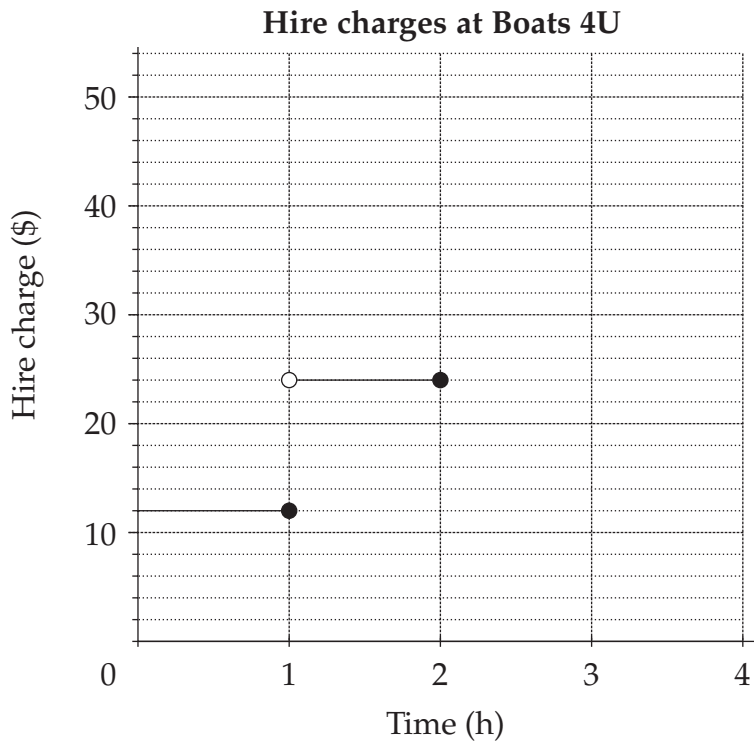

(e) Michelle said that if Hannah had hired the boat from Boats 4U it would have been cheaper.

1

Was Michelle correct? Explain your answer.

.....

.....

.....

.....

.....

.....

Marks

Question 82 (5 marks)

The diagram shows a scale drawing of a practice netball court.

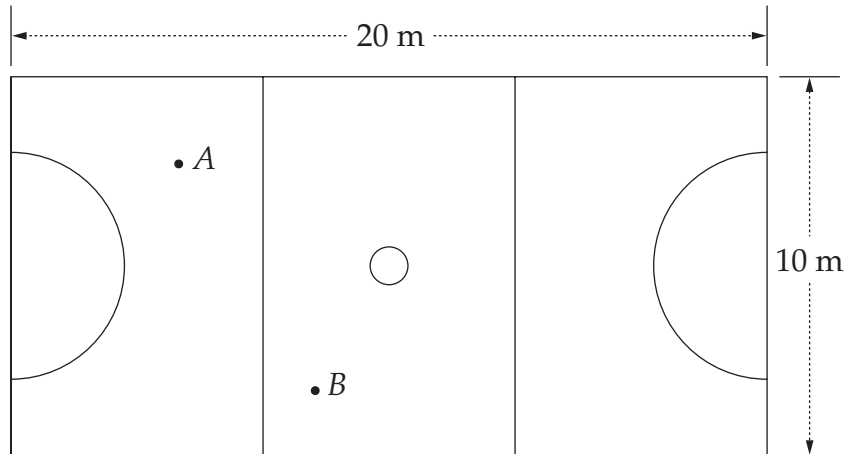

- (a) All straight lines on the court are marked with white tape. 1

How much tape was used?

.....

- (b) What scale has been used in the diagram? 1

.....

- (c) Anne (*A*) passed the ball to Barbara (*B*). 1

Use your scale from part (b) to calculate the length of the pass in metres.

.....

Marks

Question 82 (continued)

- (d) A rectangular safety fence was built around the court 3 metres from all sides. A space of 1 metre was left for a gate. **1**

How long is the safety fence?

.....
.....

- (e) Ten minutes before the end of a practice game the score was **1**

Red team 12 goals, Blue team 14 goals.

During the last ten minutes 16 goals were scored. The Red team won by 4 goals.

How many goals did the Red team score in the last ten minutes?

.....
.....

Marks

Question 83 (5 marks)

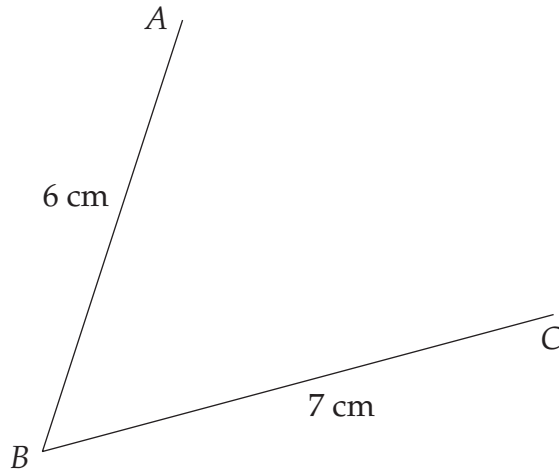

- (a) Measure the angle ABC to the nearest degree. 1

.....

- (b) AB and BC are two sides of a parallelogram. 1

Use your geometrical instruments to complete the parallelogram $ABCD$ on the diagram above.

- (c) By measurement and calculation, find the area of the parallelogram $ABCD$. 1

.....

Marks

Question 83 (continued)

- (d) WX and XY are two sides of a kite.

1

Use your geometrical instruments to complete the kite WXYZ on the diagram.

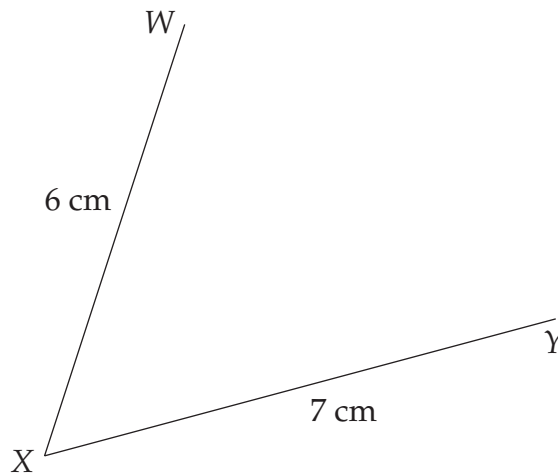

- (e) Describe ONE way in which the diagonals of a kite are DIFFERENT from the diagonals of a parallelogram.

1

.....

.....

.....

Question 84 (5 marks)

People can use mobile phones to send text messages to each other.

Two people sending a message to each other makes a total of two messages.



This can be represented geometrically as a line as shown in the table.

<i>Number of people sending messages to each other</i>	<i>Diagram</i>	<i>Number of messages</i>
2		2
3		6
4		12
5		20
6		?

	Marks
Question 84 (continued)	
(a) Complete the diagram for 5 people.	1
(b) How many messages will there be for 6 people?	1
(c) How many messages will there be for 10 people?	1
(d) How many messages will there be for n people?	1
(e) There were 240 messages sent. How many people were involved?	1

End of test

BLANK PAGE

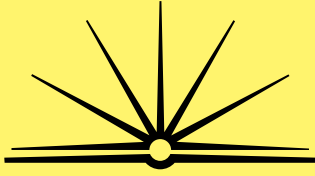

BOARD OF STUDIES
NEW SOUTH WALES

2002 SCHOOL CERTIFICATE TEST

12 November

Start 9.25 am

MATHEMATICS

**SAMPLE
QUESTIONS
& FORMULAE
BOOKLET**

General instructions

- Reading time – 5 minutes
- Working time – 2 hours
- Write using black or blue pen
- The supervisor will tell you when to begin the test
- Attempt ALL questions
- This test has TWO sections
- There will be a short break between Section 1 and Section 2
- Calculators may be used in Section 2 only
- The Sample Questions and Formulae Booklet may be used in both sections
- Write your Centre Number and Student Number at the top of page 1 (Section 1) and page 33 (Section 2 Part B)

Instructions for answering questions

- Complete your answers in either black or blue pen.
- ALL answers to questions in Section 1 and Section 2 Part B must be written in the spaces provided in the Section 1 and Section 2 Part B Question and Answer booklets.
- **Completing the diagram**

You may wish to use a pencil in questions where you are to complete a diagram.

Sample 1:

Draw a line through C ,
perpendicular to AB .

Label the point of intersection
of the two lines, M .

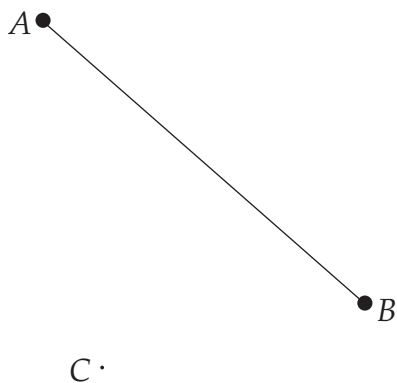

*The question has been
answered below.*

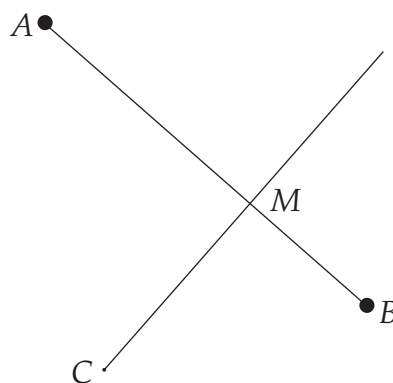

*Line CM is drawn
perpendicular to AB using a
set square or pair of compasses
and ruler.*

- **Multiple choice**

Complete your answers to the multiple-choice questions (in Section 2 Part A) on the answer sheet provided. Select the alternative A, B, C or D that best answers the question. Fill in the response oval completely.

Sample 2: $2 + 4 =$ (A) 2 (B) 6 (C) 8 (D) 9
 A B C D

If you think you have made a mistake, put a cross through the incorrect answer and fill in the new answer.

A B C D

If you change your mind and have crossed out what you consider to be the correct answer, then indicate the correct answer by writing the word **correct** and drawing an arrow as follows.

A B C D
 correct
 ↙

- **Multiple-choice questions that may have more than one correct answer**

Complete your answers to the multiple-choice questions that may have more than one correct answer in the Section 2 Part B Question and Answer Booklet.

Sample 3: $\frac{2}{3} =$ (A) $\frac{2-1}{3-1}$ (B) $\frac{2+1}{3+1}$ (C) $\frac{2 \times 1}{3 \times 1}$ (D) $\frac{2 \div 1}{3 \div 1}$
 A B C D

Two oval shapes have been filled in to show the two correct answers.

If you think you have made a mistake, put a cross through the incorrect answer and fill in the new answer, as shown in Sample 2.

If you change your mind and have crossed out what you consider to be the correct answer, then indicate the correct answer by writing the word **correct** and drawing an arrow, as shown in Sample 2.

FORMULAE

For use in SECTION 1 and SECTION 2

Circumference of a circle = $\pi \times$ diameter

$$[C = \pi d]$$

Area of a circle = $\pi \times$ radius squared

$$[A = \pi r^2]$$

Area of a parallelogram = base \times perpendicular height

$$[A = bh]$$

Area of a rhombus = half the product of the diagonals

$$\left[A = \frac{1}{2}xy \right]$$

Area of a trapezium = half the sum of the parallel sides \times perpendicular height

$$\left[A = \left(\frac{a+b}{2} \right) h \right]$$

Volume of a prism = area of cross-section \times height

$$[V = Ah]$$

Volume of a cylinder = $\pi \times$ radius squared \times height

$$[V = \pi r^2 h]$$

Pythagoras' theorem states:

In a right-angled triangle,

the hypotenuse squared = the sum of the squares of the other two sides

$$[c^2 = a^2 + b^2]$$