



BOARD OF STUDIES
NEW SOUTH WALES

**2002
SCHOOL
CERTIFICATE
TEST**

12 November

MATHEMATICS

SECTION 1

25 marks

CENTRE NUMBER

--	--	--	--	--

STUDENT NUMBER

--	--	--	--	--	--	--	--	--	--

Directions for Section 1

- You have 30 minutes to answer this section
- Write your answers to Questions 1–25 in this booklet
- Calculators are NOT to be used in this section
- Write your Centre Number and Student Number at the top of this page

Complete your answers to Questions 1–25 in this booklet.

1 Evaluate $9 - 3.74$

.....
.....

2

BEEF ROLLS
\$3.50 each
10% extra on Sundays

How much is a beef roll on Sunday?

.....
.....

3 When $8.\square 57$ is rounded to 1 decimal place the answer is 8.5.

What number should be written in the \square ?

.....
.....

- 4 Use the divided bar graph to complete the frequency table.

Year 10 Mathematics grades

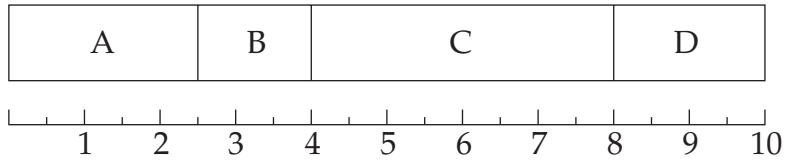

<i>Grade</i>	<i>Frequency</i>
A	30
B	18
C	<input type="text"/>
D	24

- 5 Evaluate $(2\frac{1}{2})^2$

.....

- 6 The design on a piece of fabric has stars and circles in the ratio 4 : 3.

Explain the meaning of the underlined words.

.....

- 7 The temperature in a freezer was -4°C . During a 3 hour power failure, the temperature in the freezer increased by $1\frac{1}{2}^{\circ}\text{C/h}$.

What was the temperature in the freezer at the end of the power failure?

.....

8

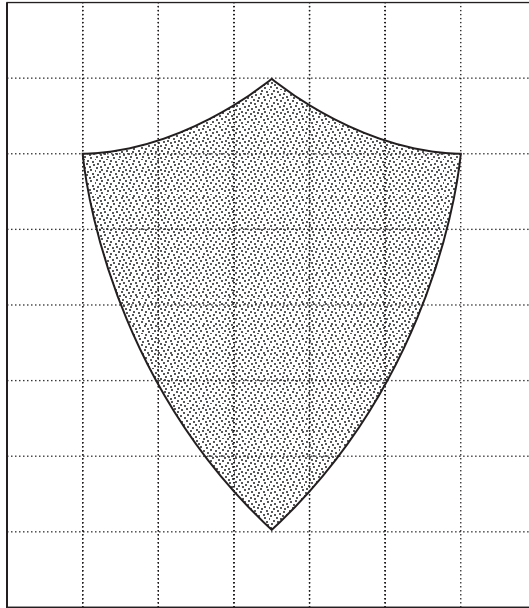

Estimate the shaded area in square centimetres.

.....

9 Two of the operations $+$, $-$, \times , \div have been left out of this number sentence.

$$8 \square 6 \square 3 = 6$$

Insert an operation in each square to make the sentence true.

10 Solve $2p - 3 = 8$

.....

11 Lucia uses 20 litres of petrol to drive 250 kilometres.

Express this rate in litres per 100 kilometres.

.....

12

$$\frac{\triangle}{3 \times \square} > 2$$

Place whole numbers less than 10 in \triangle and \square to make the statement true.

13 Sketch the view of this solid when viewed from the top.

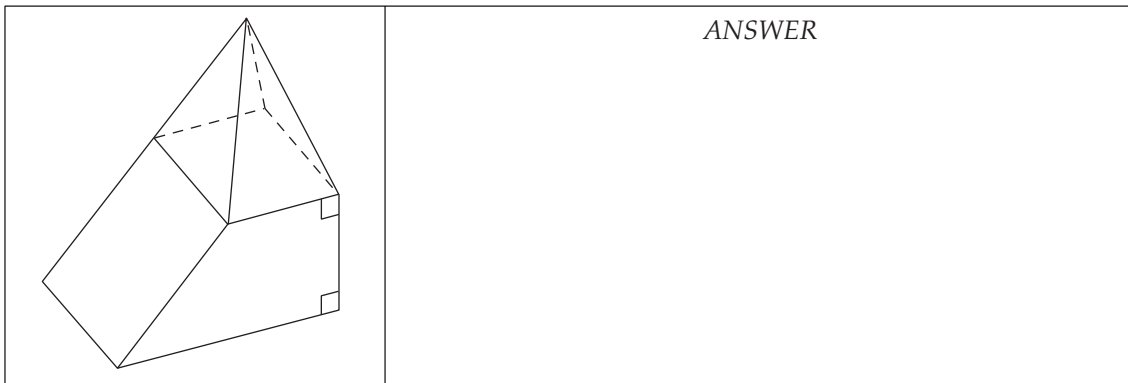

14 Narelle is paid an allowance of 25 cents per kilometre to drive to and from work. She lives 17 km from work and works 4 days a week.

Calculate her allowance for one week.

.....

.....

15 The *median* of the data shown in this stem-and-leaf plot is 116.

Stem	Leaf
10	1, 3, 7, 8
11	2, \square , 7, 8, 9
12	0, 4, 8

What is the value of \square ?

.....

.....

- 16 This figure is made up of a rectangle and a semi-circle.

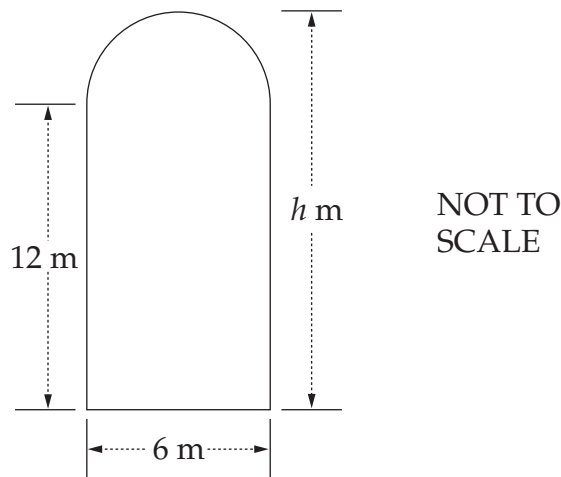

Calculate the value of h .

.....

- 17 Dieter's grandmother was 42 years old when Dieter was born. His grandmother was three times his age when she retired.

How old was Dieter when his grandmother retired?

.....

18 $\sqrt{\square^2 + 12^2} = 13$

Write a number in the square to make this a true statement.

19

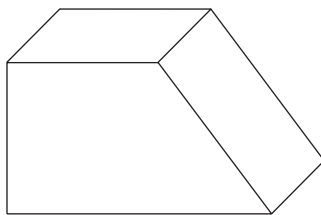

Draw ALL lines to complete the net of the prism.

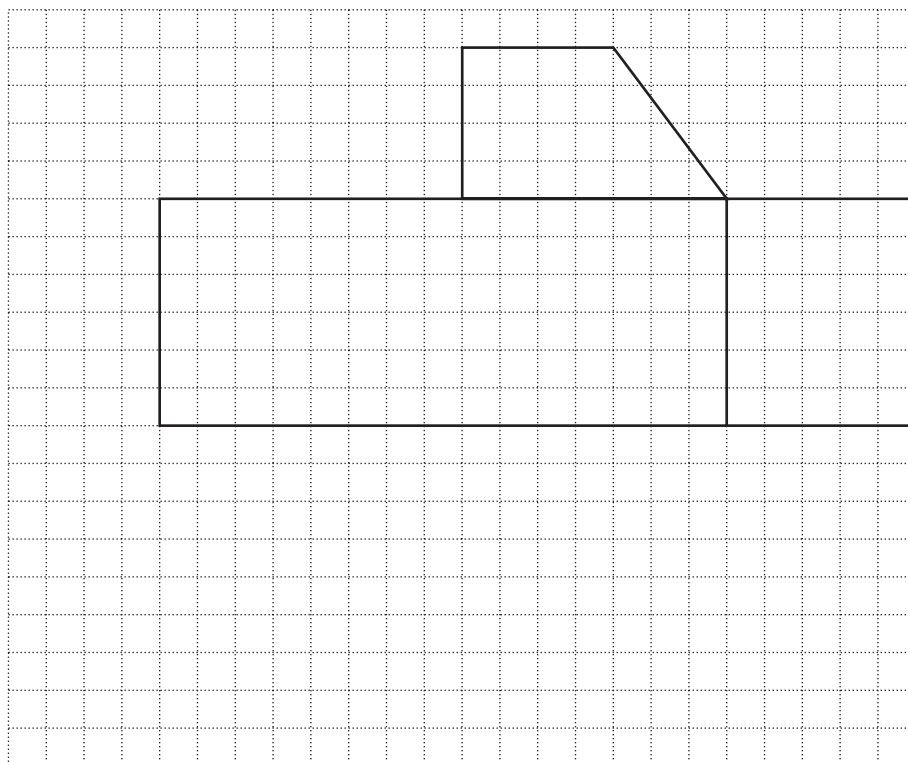

20 Consider the pattern.

$$5^3 - 4^3 = 5^2 + 5 \times 4 + 4^2 = 61$$

$$6^3 - 5^3 = 6^2 + 6 \times 5 + 5^2 = 91$$

$$7^3 - 6^3 = 7^2 + 7 \times 6 + 6^2 = 127$$

Using this pattern, complete:

$$10^3 - 9^3 = \square + \square \times \square + \square = 271$$

- 21 The average weight of 5 pumpkins was 2.4 kg. When 1 pumpkin was sold, the average weight of the remaining pumpkins was 2.5 kg.

How heavy was the pumpkin that was sold?

.....

.....

- 22 Peter has a bag that contains a total of 12 marbles. Some are red and some are blue. Peter took a marble out of the bag at random, recorded its colour, then put it back into the bag before he took another marble. He did this 20 times.

This table shows his results.

<i>Colour</i>	<i>Number of times</i>
Blue	
Red	
Total	20

What is the most likely number of red marbles in Peter's bag?

.....

.....

23

Prism I

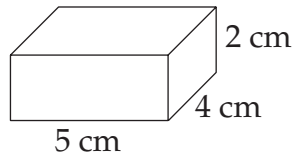

Prism II

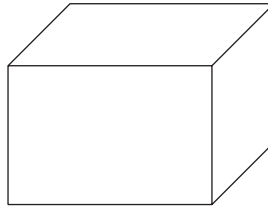

NOT TO SCALE

The volume of Prism II is four times the volume of Prism I.

What could be the dimensions of Prism II?

Length = cm

Breadth = cm

Height = cm

24 George went fishing. He recorded his catch on a bar graph but forgot to label it.



He caught twice as many *flathead* as *breem*.

He also caught some *tailor* and 2 *snapper*.

How many *tailor* did he catch?

.....

Please turn over

- 25 Pirates have buried treasure on Lone Palm Island.
The treasure is south-west of the cave.
Its distance from the palm tree is the same as its distance from the cave.
The positions of the palm tree and the cave are marked with dots.
The cave is due north of the palm tree.

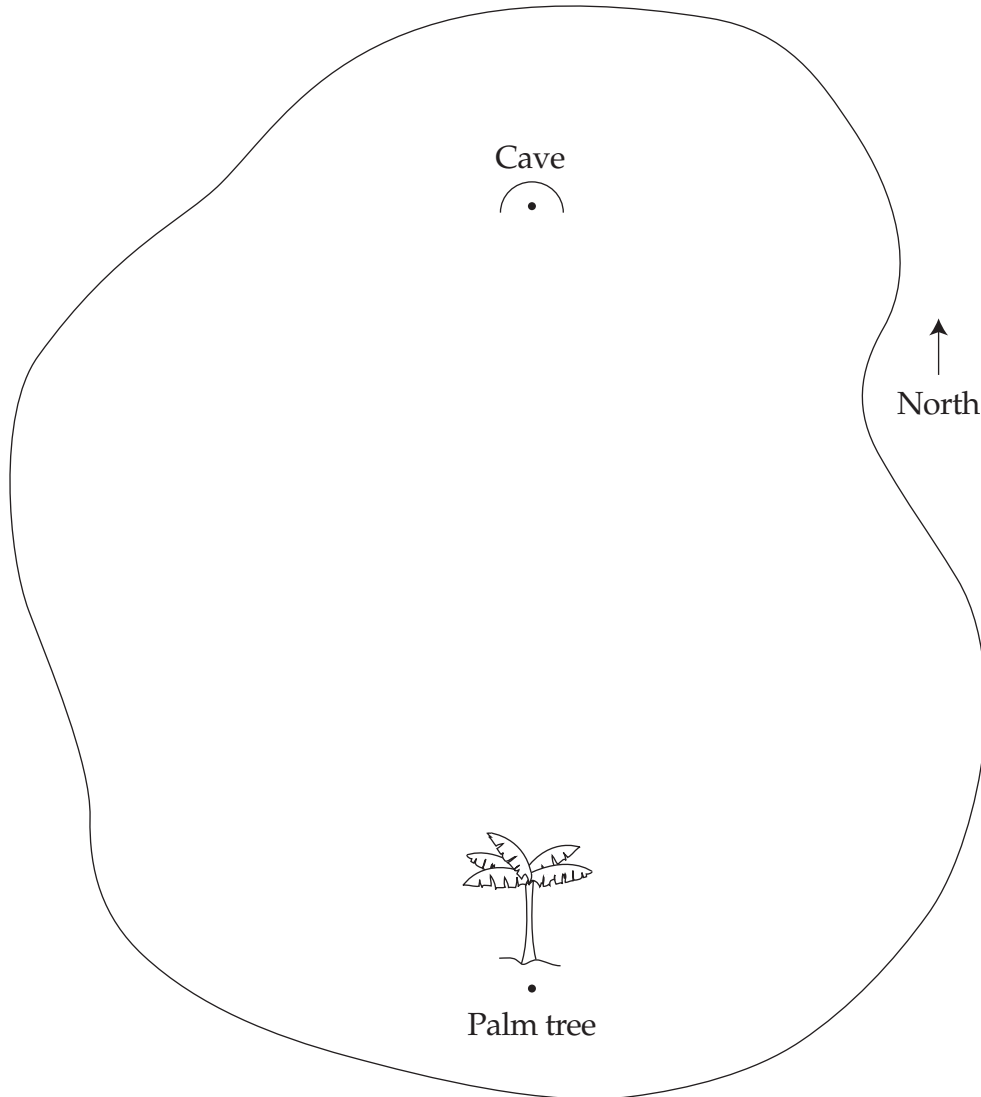

Use your geometrical instruments to locate the treasure. Mark the spot with an X.

End of Section 1

BLANK PAGE

BLANK PAGE