

BOARD OF STUDIES  
NEW SOUTH WALES

# 2004 SCHOOL CERTIFICATE TEST

## Mathematics

--	--	--	--	--

Centre Number

--	--	--	--	--	--	--	--	--	--

Student Number

### Section 1 Pages 1–8

**25 marks**

You have 30 minutes for this section

Answer Questions 1–25 in the spaces provided

Calculators are NOT to be used in this section

There will be a short break between Section 1 and Section 2

### Section 1

25 marks

Answer Questions 1–25 in the spaces provided.

1 What number is halfway between  $-3$  and  $7$ ?

.....  
 .....

2  $1\frac{1}{2} \times \frac{1}{5} =$

.....  
 .....

3  $O$  is the centre of the circle. Use the words from the list to complete the sentences below.

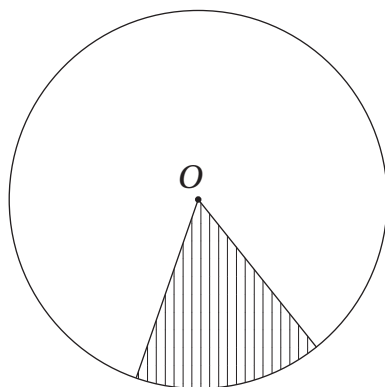

- an arc
- a chord
- a sector

The shaded area is called .....

This area is bounded by two radii and .....

4  $1.8 \div 0.03 =$

.....  
 .....

- 5 Sergio said ‘If I toss 2 coins, I can get 2 heads, or 2 tails, or a head and a tail. Therefore the probability that I get 2 heads is  $\frac{1}{3}$ ’.

Sergio is incorrect. Write a brief reason why he is incorrect.

.....  
 .....

- 6 Jarrod has 43 stickers, Timothy has 27 and Abigail has 14. Jarrod wants them to share the stickers equally.

How many stickers will Jarrod have to give away so that all three children have the same number of stickers?

.....  
 .....  
 .....  
 .....

- 7 Which number in the box is:

smaller than 870  
 AND greater than 540  
 AND even  
 AND divisible by 3?

486	888
	639
762	572

The number is .....

- 8 Tides alternate between low and high. The time between low tide and high tide at Brown’s Beach is 6 hours and 10 minutes. There is a low tide at 7:13 am.

When will the next low tide occur?

.....  
 .....

9 Calculate the sum

$$2 + 4 + 16 + 18 + 2 + 4 + 16 + 18 + 2 + 4 + 16 + 18$$

.....  
 .....

10

If  $12 \times 167 = 2004$

then  $24 \times \square = 2004$

The value of  $\square$  is .....

11 Arrange these scores into a stem-and-leaf plot.

14, 17, 20, 22, 23, 23, 24, 33

Stem	Leaf
1	
2	
3	

12 In Question 11, the mean of the scores is 22. Change any one of the scores to make the mean 23.

Old score		New score
	changes to	

13

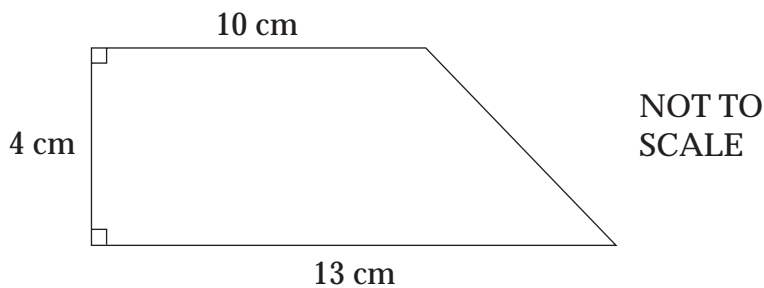

Calculate the perimeter of the trapezium.

.....  
 .....

- 14 Khadija thought of a number. After she doubled the number, she subtracted five and the result was 63.

What was the number Khadija first thought of?

.....

.....

- 15 Write a number in the box so that the expression

$$\frac{\square + 3}{8}$$

has a value between 1 and 2.

- 16 A sequence is formed by adding the two previous numbers together. Fill in the two missing numbers in this sequence.

4, ....., ....., 22

- 17

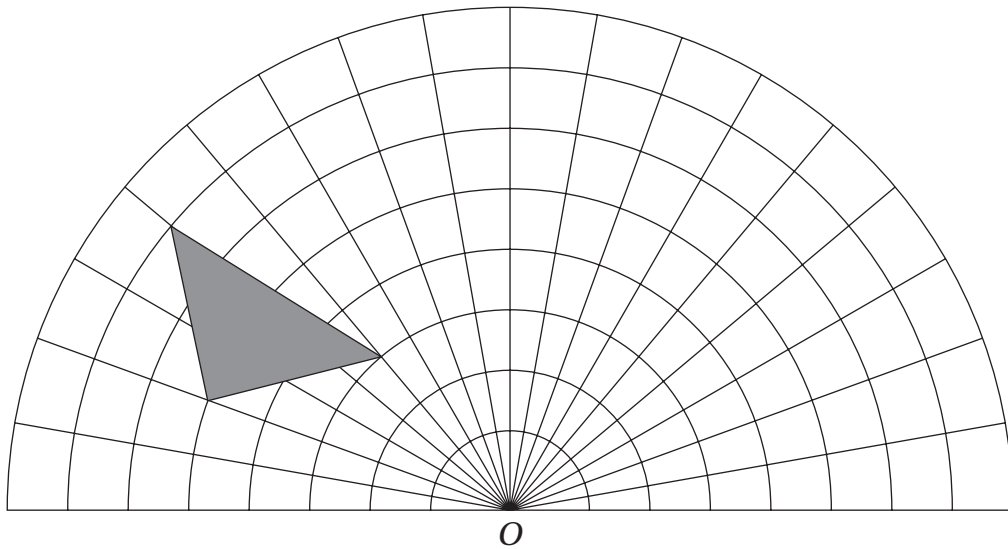

Rotate the triangle through 60° about O in a clockwise direction.

Draw the triangle in its new position.

**18** What is the greatest number of 60 cent chocolates I can buy with \$10?

.....  
.....  
.....

**19** A rail ticket cost \$12. After a price rise the same ticket cost \$15.

What percentage increase was the price rise on the original cost?

.....  
.....

**20** By measuring appropriate lengths, calculate the area of this triangle in  $\text{cm}^2$ .

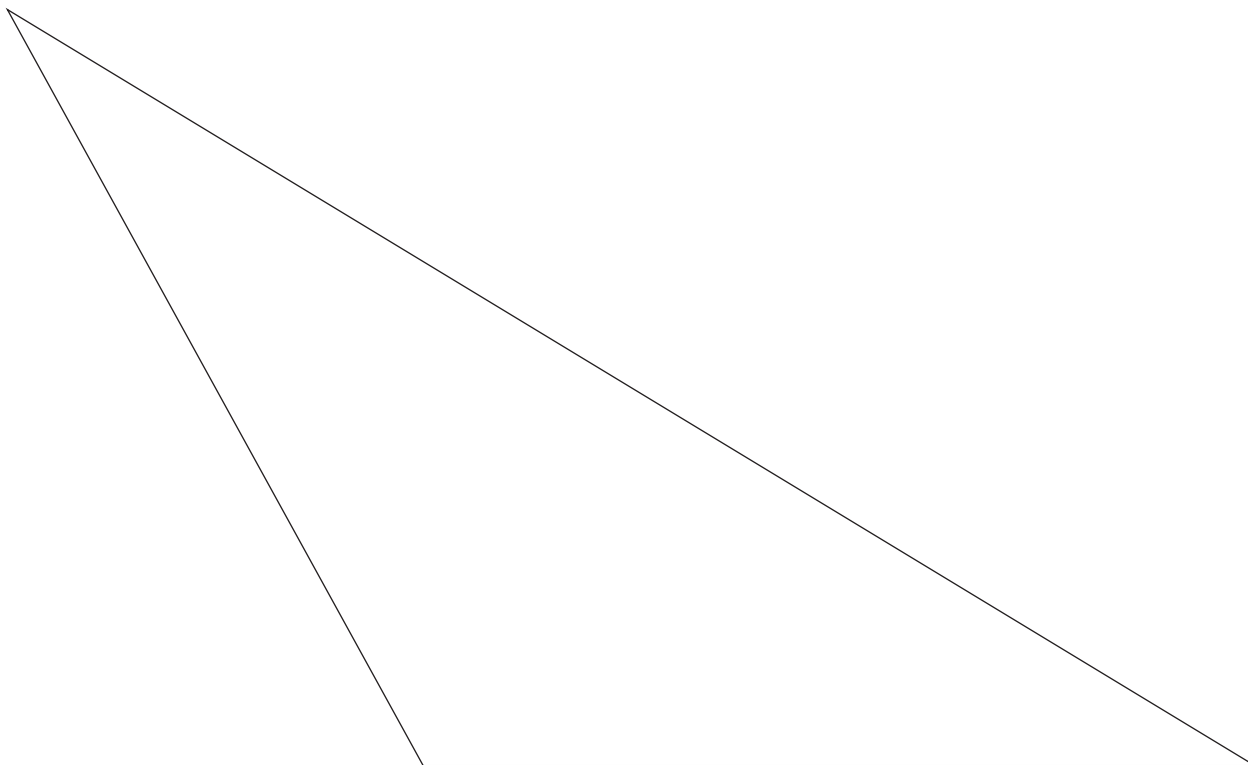

.....  
.....

21 Write the next line of this pattern

$$1 \times 2 \times 3 \times 4 + 1 = 5^2$$

$$2 \times 3 \times 4 \times 5 + 1 = 11^2$$

$$3 \times 4 \times 5 \times 6 + 1 = 19^2$$

$$4 \times 5 \times 6 \times 7 + 1 = 29^2$$

.....

22

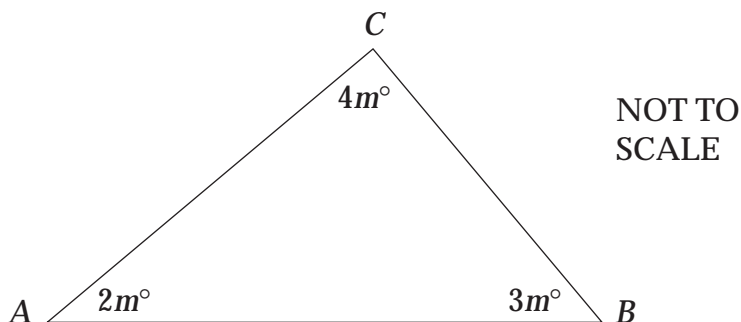

Triangle  $ABC$  has angles  $2m^\circ$ ,  $3m^\circ$  and  $4m^\circ$  as shown.

Use an equation, or a calculation, to show that  $m = 20$ .

.....  
.....

23 Triangle  $ABC$  in Question 22 is not drawn to scale. Circle the term that best describes triangle  $ABC$ .

Isosceles

Right-angled

Acute-angled

Obtuse-angled

- 24 More than one triangle can be constructed with sides 6 cm and 8 cm and an angle of  $40^\circ$ .  $\triangle XYZ$  is one example.

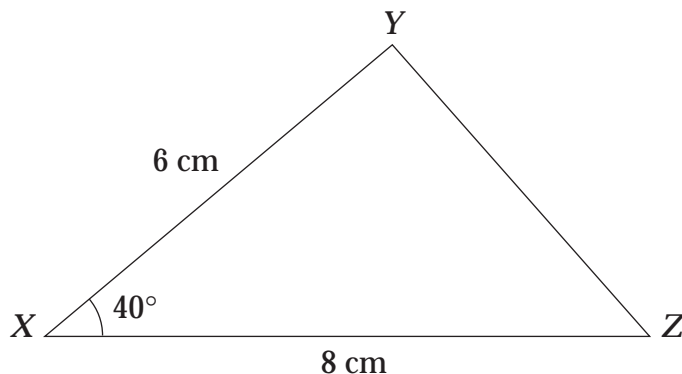

Construct another triangle that is NOT congruent to  $\triangle XYZ$  and that has sides 6 cm and 8 cm and an angle of  $40^\circ$ .

- 25 Using all of the following numbers and symbols only once, write a correct number sentence.

2, 3, 4, 5, +, -, =

.....

.....

**End of Section 1**

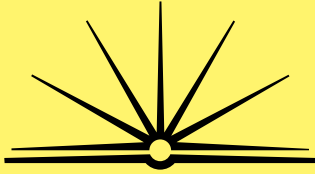

**BOARD OF STUDIES**  
NEW SOUTH WALES

**2004  
SCHOOL  
CERTIFICATE  
TEST**

**Mathematics**

**Section 2** Pages 9–32

**75 marks**

You have 1 hour and 30 minutes for this section

This section has TWO parts

Part A – 50 marks      Questions 26–75

Part B – 25 marks      Questions 76–84

Calculators may be used in this section

Do not commence Section 2 until you are instructed to do so



- 29 Abdul wrote the following lines of working to solve the following equation:

$$5x + 7 = 16$$

Line 1  $5x = 16 - 7$

Line 2  $5x = 9$

Line 3  $x = \frac{9}{5}$

Line 4  $x = 1\frac{4}{9}$

In which line did he make an error?

- (A) Line 1      (B) Line 2      (C) Line 3      (D) Line 4
- 
- 30 Maureen was born on 26 November 1990. What was her age on 26 August 2004?
- (A) 13 years 8 months      (B) 13 years 9 months  
(C) 14 years 8 months      (D) 14 years 9 months
- 

- 31 Michelle drew a circle inside a rectangle. She drew a diameter of the circle and extended it. When she extended the diameter, it was a diagonal of the rectangle.

Which of the following could be Michelle's drawing?

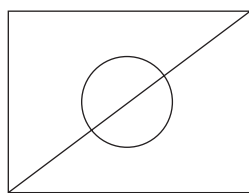

(A)

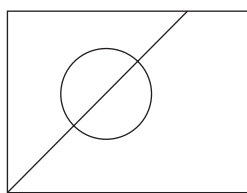

(B)

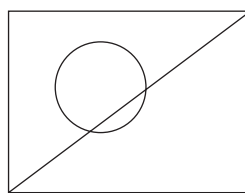

(C)

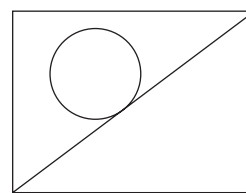

(D)

- 
- 32 Which of the following scales would be the most appropriate to make a scale drawing of a police car on a piece of paper the same size as this page?
- (A) 1 : 25      (B) 1 : 100      (C) 1 : 250      (D) 1 : 1000
-

- 33 The possible three-child families are

*BBB, BBG, BGB, BGG, GBB, GBG, GGB, GGG*

where  $B = \text{boy}$ ,  $G = \text{girl}$ .

What is the probability that in a three-child family there will be AT LEAST ONE girl?

- (A)  $\frac{3}{8}$                       (B)  $\frac{4}{8}$                       (C)  $\frac{6}{8}$                       (D)  $\frac{7}{8}$

- 34 Expand and simplify  $3(t - 1) - t + 1$

- (A)  $2t + 4$                       (B)  $2t - 4$                       (C)  $2t - 2$                       (D)  $2t$

- 35 The diagram shows a cube with two shaded faces. Which of the following nets is NOT the net for this cube?

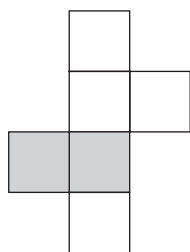
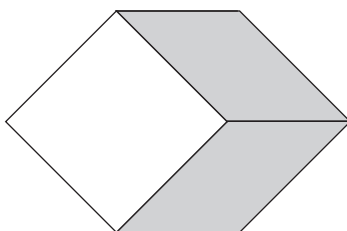

(A)

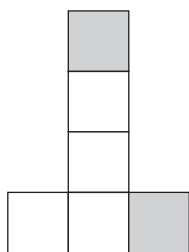

(B)

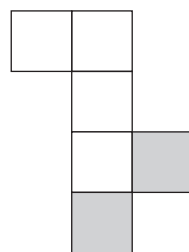

(C)

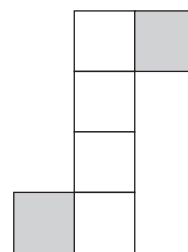

(D)

- 36 Which of the following could represent the probability of an event that is LIKELY to occur?

- (A)  $\frac{1}{9}$                       (B)  $\frac{2}{5}$                       (C)  $\frac{1}{2}$                       (D)  $\frac{4}{5}$

- 37 Peta sells cars. She earns \$270 per week plus 5% commission on her total weekly sales over \$40 000.

What is the value of her sales in a week when she earns \$860?

- (A) \$11 800  
(B) \$17 200  
(C) \$51 800  
(D) \$57 200

- 38 Alice is going to use this pattern to pave her courtyard.

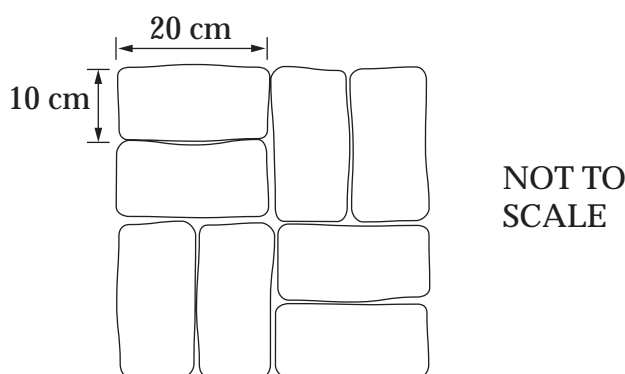

She is going to pave an area of  $12 \text{ m}^2$ . How many  $20 \text{ cm} \times 10 \text{ cm}$  pavers will she need?

- (A) 75                      (B) 150                      (C) 240                      (D) 600
- 39 Darren has  $\$x$  in his bank account and he saves  $\$y$  every week. How much will be in his account after  $n$  weeks?

- (A)  $x + yn$               (B)  $xn + yn$               (C)  $xn + y$               (D)  $x + y + n$

- 40 Helena's home repayments increased from \$962.22 to \$984.24 per fortnight.

How much extra will Helena repay each year?

- (A) \$264.24              (B) \$528.48              (C) \$572.52              (D) \$1145.04

- 41 Using a protractor, find the size of  $x$ .

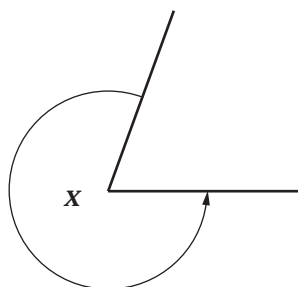

- (A)  $70^\circ$                       (B)  $110^\circ$                       (C)  $250^\circ$                       (D)  $290^\circ$

- 42 Which statement about cylinders  $P$  and  $Q$  is true?

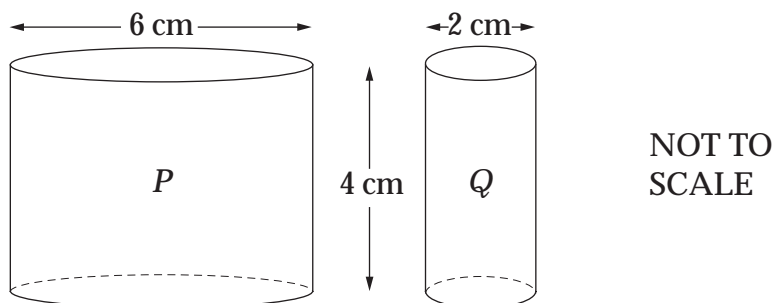

- (A) The volume of  $P$  is  $113.1 \text{ cm}^3$  and it is three times the volume of  $Q$ .  
 (B) The volume of  $P$  is  $113.1 \text{ cm}^3$  and it is nine times the volume of  $Q$ .  
 (C) The volume of  $P$  is  $452.4 \text{ cm}^3$  and it is three times the volume of  $Q$ .  
 (D) The volume of  $P$  is  $452.4 \text{ cm}^3$  and it is nine times the volume of  $Q$ .

- 43 Which of these expressions is equivalent to  $3mn^2$ ?

- (A)  $3 \times m \times n \times n$                       (B)  $3 \times m \times n \times 2$   
 (C)  $3 \times m \times n \times m \times n$                       (D)  $3 \times m \times n \times 3 \times m \times n$

- 44 Gertrude normally works four-hour shifts. She is paid \$8.50 per hour normal time and \$12.50 per hour for any time she works over four hours. She works a shift from 9:15 am to 2:15 pm.

What is her total pay?

- (A) \$42.50                      (B) \$46.50                      (C) \$62.50                      (D) \$71.50

- 45  $EFGH$  is a parallelogram.  $MH$  is perpendicular to  $EF$ .

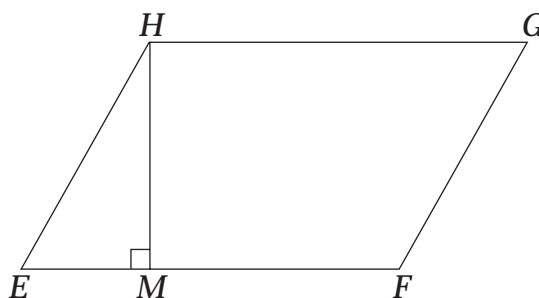

Which of the following are enough to find the area of  $EFGH$ ?

- (A) The lengths of  $HG$  and  $EH$  only  
 (B) The lengths of  $HG$  and  $MH$  only  
 (C) The lengths of the diagonals  $EG$  and  $HF$  only  
 (D) The lengths of  $EH$  and  $MH$  only

- 46 Find the area of the shape.

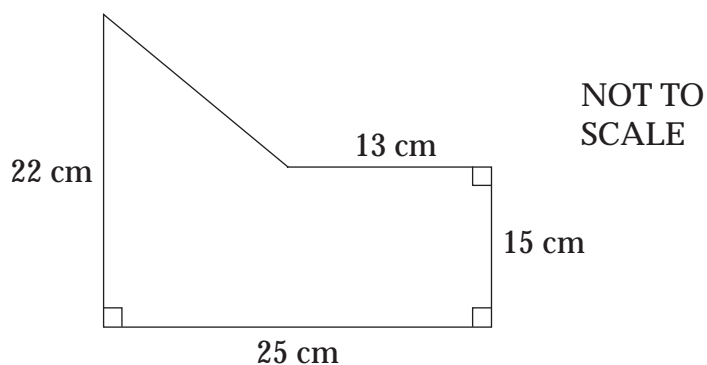

- (A)  $417 \text{ cm}^2$       (B)  $459 \text{ cm}^2$       (C)  $507 \text{ cm}^2$       (D)  $639 \text{ cm}^2$

- 47 What direction is Canberra from Bourke?

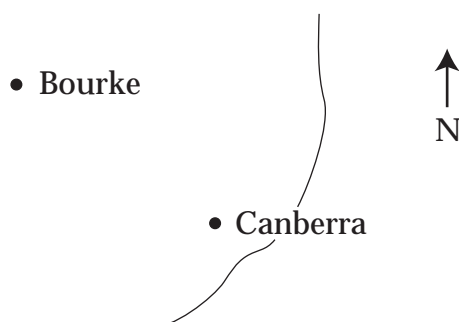

- (A) NW      (B) NE      (C) SW      (D) SE

- 48 Which point is closest to 3.15?

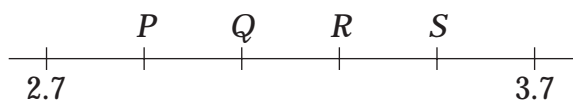

- (A) *P*                      (B) *Q*                      (C) *R*                      (D) *S*
- 
- 49 When he climbed a 60 m tree, Ross climbed 140 rungs on his ladder. He plans to climb a 75 m tree.
- How many rungs will be on the ladder?
- (A) 155                      (B) 175                      (C) 200                      (D) 215
- 
- 50 The diagram is the net of a rectangular prism, drawn to a scale 1 : 2.

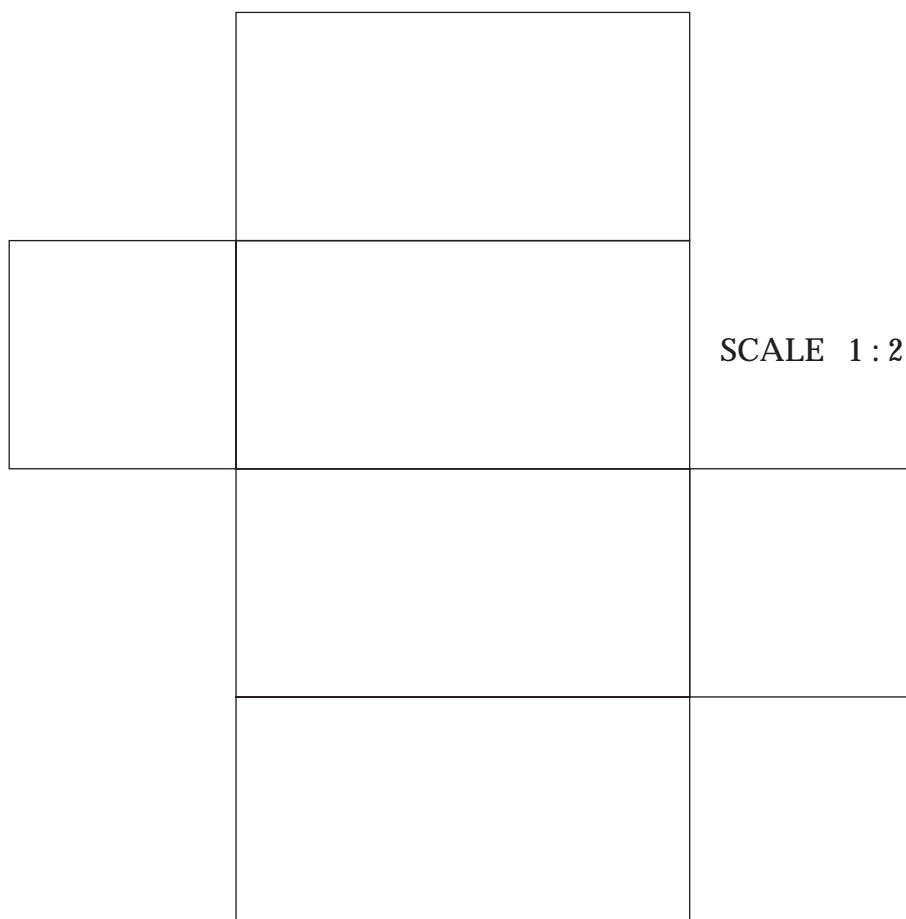

What is the volume of the prism?

- (A)  $27 \text{ cm}^3$                       (B)  $54 \text{ cm}^3$                       (C)  $108 \text{ cm}^3$                       (D)  $432 \text{ cm}^3$

- 51 Barbara wrote each letter of her name on separate cards.



She placed the cards face down on a table. She is going to turn over two cards at the same time.

In how many ways can she turn over two cards that have the same letter on them?

- (A) 3                      (B) 4                      (C) 5                      (D) 10

52

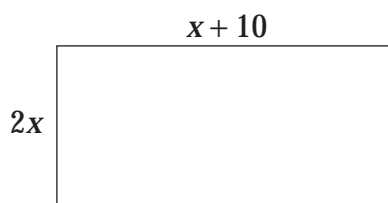

What is the perimeter of this rectangle?

- (A)  $3x + 10$                       (B)  $4x + 20$   
 (C)  $5x + 10$                       (D)  $6x + 20$

- 53 The balances show the relationships between the masses of three objects.

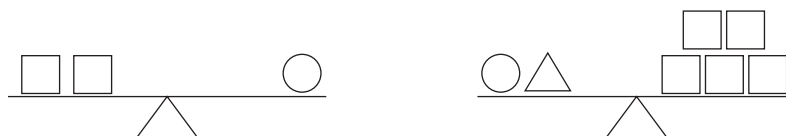

Arrange the three objects from heaviest to lightest.

- (A)  $\triangle, \circ, \square$                       (B)  $\circ, \square, \triangle$   
 (C)  $\square, \triangle, \circ$                       (D)  $\triangle, \square, \circ$

- 54 Which of the following containers could hold  $\frac{1}{2}$  litre of water without overflowing?

(A)

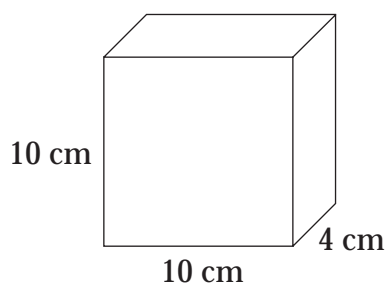

(B)

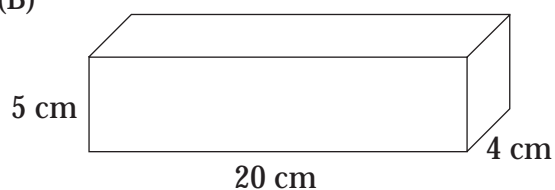

(C)

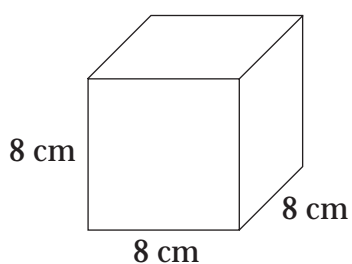

(D)

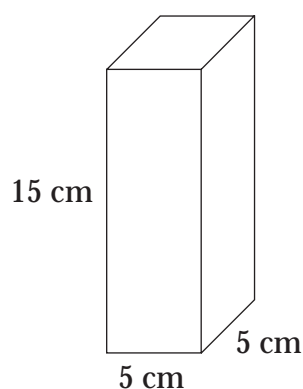

- 55 The graph shows the number of errors made by a class of students in a Year 10 mathematics test.

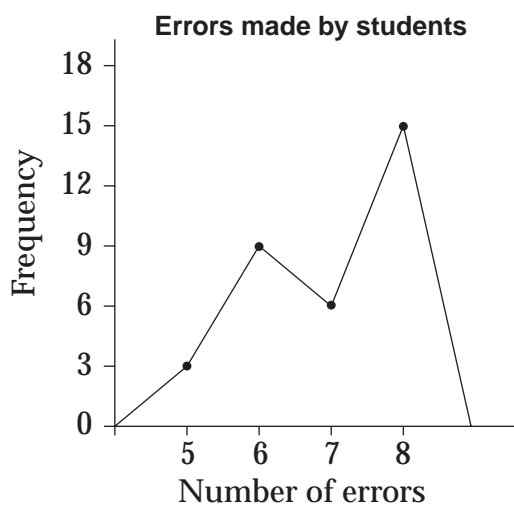

How many students are in the class?

- (A) 4                      (B) 15                      (C) 23                      (D) 33

56

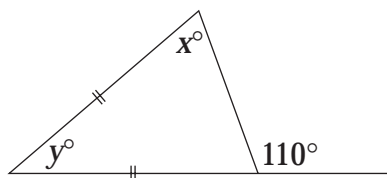

What are the values of  $x$  and  $y$ ?

- (A)  $x = 40, y = 70$                       (B)  $x = 55, y = 55$   
 (C)  $x = 50, y = 60$                       (D)  $x = 70, y = 40$

- 57 A discount voucher offered 25% discount, up to a maximum discount of \$15. Daniel bought goods to the value of \$80 and Naomi bought goods to the value of \$40. They each had a discount voucher.

How much more money did Daniel pay than Naomi?

- (A) \$5                      (B) \$10                      (C) \$30                      (D) \$35

- 58 A supermarket sells soap powder in different sized packages. Which is the best buy?

- (A) 750 g for \$2.49                      (B) 1 kg for \$3.28  
 (C) 1.7 kg for \$5.65                      (D) 2 kg for \$6.75

- 59 In the diagram, lengths  $BC$ ,  $CD$  and  $BD$  are equal and  $\angle BEA$  is a right angle.

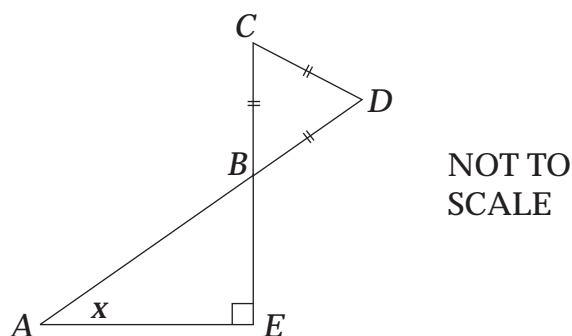

What is the size of  $x$ ?

- (A)  $30^\circ$                       (B)  $35^\circ$                       (C)  $45^\circ$                       (D)  $60^\circ$

- 60 David earns \$7.67 an hour for an 8 hour shift. John earns \$6.97 an hour and receives a \$5.60 meal allowance for an 8 hour shift.

Which of the following statements is correct for an 8 hour shift?

- (A) They receive the same amount.  
 (B) David receives \$5.60 more than John.  
 (C) John receives \$4.90 more than David.  
 (D) John receives \$11.20 more than David.

- 61 Ali wants to inscribe a regular polygon in this circle. He marks 12 equally spaced points on the circumference.

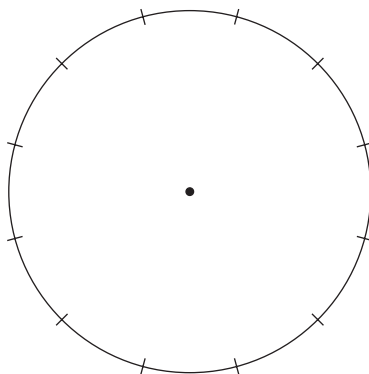

Which regular polygon can he NOT make from this construction?

- (A) Equilateral triangle                      (B) Hexagon  
 (C) Octagon                                      (D) Square

62

Score $x$	Tally	Frequency $f$	$f \times x$
1		10	10
2		6	12
3		2	6
4		1	4
5		3	15

What is the mean of this set of scores?

- (A)  $\frac{22}{5}$                       (B)  $\frac{47}{5}$                       (C)  $\frac{47}{15}$                       (D)  $\frac{47}{22}$

- 63** Michael won \$240. He donated  $\frac{1}{3}$  of his winnings to charity. He divided the remainder between his savings account and his investment account in the ratio 3 : 5.

How much will he deposit in his savings account?

- (A) \$30                      (B) \$60                      (C) \$90                      (D) \$100

- 64** The time in Maitland is  $\frac{1}{2}$  hour ahead of the time in Broken Hill. The time in Albany is  $1\frac{1}{2}$  hours behind the time in Broken Hill.

When the time in Maitland is 13:30, what is the time in Albany?

- (A) 11:30                      (B) 12:30                      (C) 14:30                      (D) 15:30

- 65** The annual membership fee at Jerry's golf club is \$345 and it costs \$15 to play each game. Jerry's golf budget for 2005 is \$900.

How many games of golf will Jerry be able to play at his club in 2005?

- (A) 23                      (B) 37                      (C) 60                      (D) 83

**66**

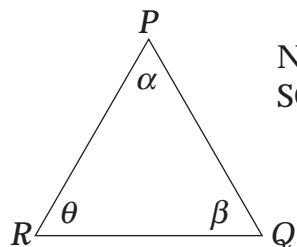

NOT TO  
SCALE

In  $\triangle PQR$ , sides  $PQ$  and  $RQ$  are equal and side  $PR$  is shorter than side  $PQ$ .

Which statement is true?

- (A)  $\alpha = \theta$                       (B)  $\alpha = \beta$   
(C)  $\theta = \beta$                       (D)  $\alpha$ ,  $\beta$  and  $\theta$  are all equal

- 67** A balba tree grows  $2\frac{1}{2}$  cm each year. Approximately how many years old will the tree be when it stands 3 m tall?

- (A) 83                      (B) 120                      (C) 830                      (D) 1200

- 68 Jim and Kevin are playing a game using a spinner. A player wins when the spinner stops on his colour. Jim always chooses green and Kevin always chooses white.

Which spinner should Kevin choose so that he has the greatest chance of beating Jim?

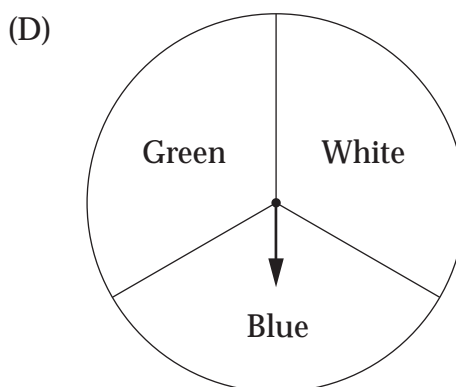
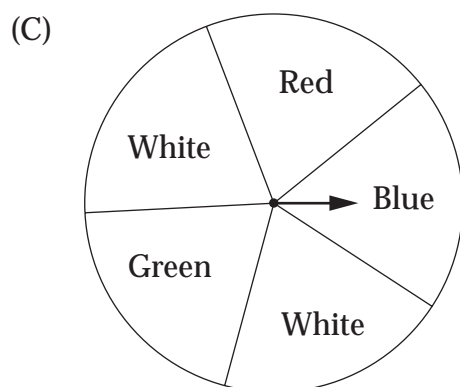
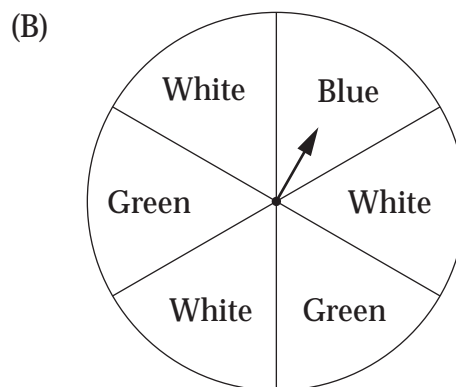
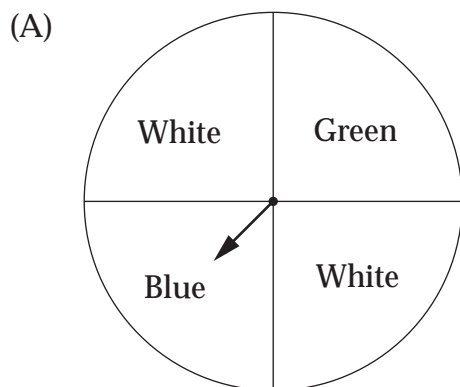

- 69 Madi covered the front page of this examination paper with \$2 coins. She placed as many coins on the page as possible without overlapping.



ACTUAL SIZE

What is the approximate value of the coins?

- (A) \$140–\$218                      (B) \$220–\$276  
 (C) \$278–\$330                      (D) \$332–\$380

- 70 Ervino took his family for dinner. The cost of each meal was: Ervino, \$24; Chris, \$18; Rebecca, \$20; and Ben, \$22. Ervino paid the total bill, using two of these discount vouchers.

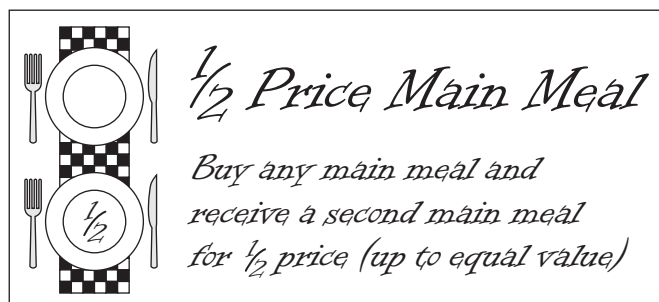

What is the lowest total amount he could be required to pay?

- (A) \$61                      (B) \$62                      (C) \$64                      (D) \$65

- 71 Aisha is looking at a map of caves.

Jimbo cave is 90 m below ground level.  
Lateral cave is 50 m higher than Cathedral cave.  
Jimbo cave is 20 m lower than Lateral cave.

How far below ground level is Cathedral cave?

- (A) 60 m                      (B) 120 m                      (C) 140 m                      (D) 160 m

- 72 What is the area of rectangle  $ABCD$ ?

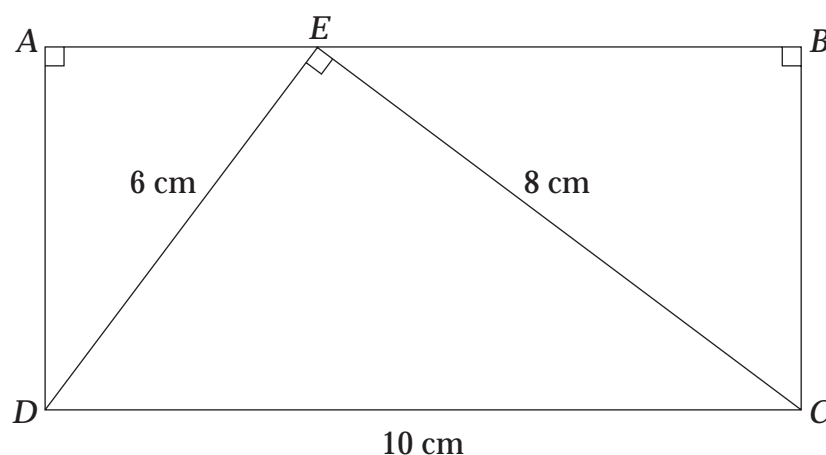

- (A)  $24 \text{ cm}^2$                       (B)  $48 \text{ cm}^2$                       (C)  $50 \text{ cm}^2$                       (D)  $60 \text{ cm}^2$

- 73 In a group of 19 boys, all play either tennis or rugby, and some play both. 14 boys play tennis and 8 play rugby.

One of the boys is selected at random. What is the probability that he plays tennis but not rugby?

- (A)  $\frac{5}{19}$                       (B)  $\frac{6}{19}$                       (C)  $\frac{11}{19}$                       (D)  $\frac{14}{19}$

- 74 The formula for the perimeter of a rectangle is

$$P = 2\ell + 2b.$$

What is the value of  $b$  when  $\ell = 5$  and  $P = 40$ ?

- (A) 15                      (B) 25                      (C) 30                      (D) 35
- 75 Peter built a maze. He threw a ball into the top of the maze.

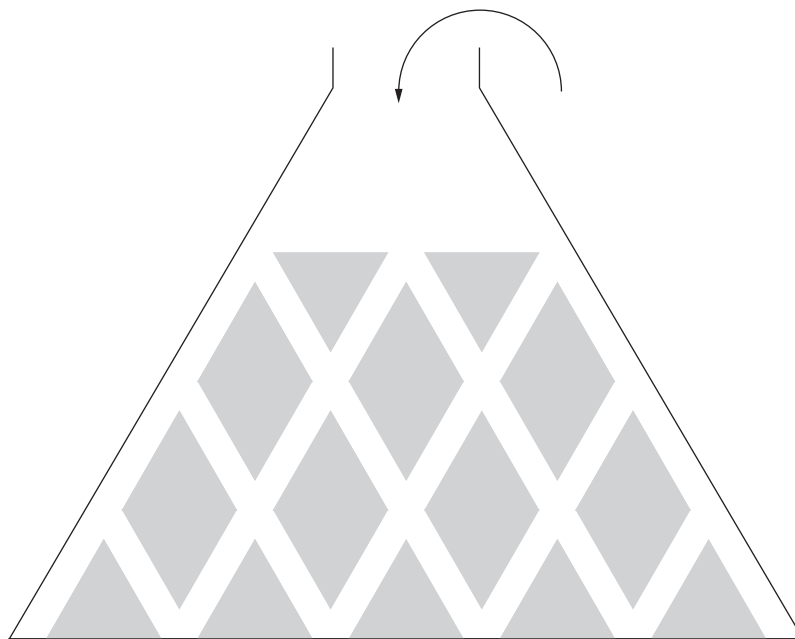

How many different paths can the ball take to fall to the bottom of the maze?

- (A)  $3 \times 2 \times 2$                       (B)  $3 \times 4 \times 5$   
(C)  $6 \times 2 \times 2$                       (D)  $6 \times 8 \times 10$

## Section 2 (continued)

--	--	--	--	--

## PART B

Centre Number

## Instructions for Questions 76–80

--	--	--	--	--	--	--	--	--

Student Number

Questions 76–80 are worth 1 mark each.

For Questions 76–80, fill in the response oval(s) corresponding to the correct answer(s). Each question may have one, two, three or four correct answers.

**Sample:**  $\frac{2}{3} =$  (A)  $\frac{2-1}{3-1}$  (B)  $\frac{2+1}{3+1}$  (C)  $\frac{2 \times 1}{3 \times 1}$  (D)  $\frac{2 \div 1}{3 \div 1}$

A  B  C  D

In the sample question, three ovals have been filled in to show the correct answer(s) to be (B), (C) and (D).

If you think you have made a mistake, put a cross through the incorrect answer. If you change your mind and have crossed out what you consider to be a correct answer, indicate this by writing the word *correct* and drawing an arrow, as shown below.

A  B  C  D

*correct* ↙

This sample indicates that (C) and (D) are the correct answers.

**Question 76**

Which of the three words, in the order given, can be used to complete this sentence to make a statement that is ALWAYS true?

The \_\_\_\_\_ of a \_\_\_\_\_ are \_\_\_\_\_.

- (A) faces, cube, congruent
- (B) sides, rhombus, equal
- (C) diagonals, kite, perpendicular
- (D) angles, parallelogram, equal

(A)                       (B)                       (C)                       (D)

**Question 77**

Fatima is making a pattern with matches.

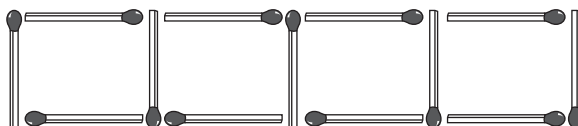

Which of the rules can be used to describe the number of matches she needs?

- (A) Three times the number of squares plus one
- (B) Four more than three times the number of squares
- (C) Four times the number of squares minus one
- (D) Twice the number of squares plus one more than the number of squares

(A)                       (B)                       (C)                       (D)

**Question 78**

The minute hand of a clock is between 3 and 4 and the hour hand is between 7 and 8.

What could the time be on a digital watch?

- (A) 3:39                      (B) 7:18                      (C) 8:17                      (D) 19:16

(A)                       (B)                       (C)                       (D)

**Question 79**

Angles  $x$ ,  $y$  and  $z$  are the three angles that make a revolution.  $x$  is acute and  $y$  is obtuse.

What type of angle could  $z$  be?

(A) Acute

(B) Obtuse

(C) Straight

(D) Reflex

(A)

(B)

(C)

(D)

---

**Question 80**

The perimeter of a rectangle is 24 cm.

What could the area of the rectangle be?

(A)  $11 \text{ cm}^2$

(B)  $27 \text{ cm}^2$

(C)  $35 \text{ cm}^2$

(D)  $40 \text{ cm}^2$

(A)

(B)

(C)

(D)

---

**Please turn over**

**Section 2 – Part B (continued)**

**Questions 81–84**

Answer the questions in the spaces provided.

**Marks**

**Question 81** (5 marks)

Two dice, with faces 0, 1, 2, 3, 4, 5, are thrown.

The possible outcomes are

0, 0	0, 1	0, 2	0, 3	0, 4	0, 5
1, 0	1, 1	1, 2	1, 3	1, 4	1, 5
2, 0	2, 1	2, 2	2, 3	2, 4	2, 5
3, 0	3, 1	3, 2	3, 3	3, 4	3, 5
4, 0	4, 1	4, 2	4, 3	4, 4	4, 5
5, 0	5, 1	5, 2	5, 3	5, 4	5, 5

- (a) Brad adds the two numbers on the dice. Find the probability that he obtains a score greater than 7. **1**

.....  
 .....

- (b) Brad intends to throw the pair of dice 300 times. When he adds the numbers, how many times would he expect to obtain a score of 5? **1**

.....  
 .....

- (c) Sue multiplies the two numbers on the dice. What is her most likely score? **1**

.....

- (d) On the same roll of the dice, Brad’s score is the same as Sue’s score. In how many ways is this possible? **1**

.....  
 .....

- (e) George throws the dice. The numbers have a product greater than 10 and a sum smaller than 9. **1**

Write down a pair of numbers that George could have thrown.

.....  
 .....

**Question 82** (5 marks)

**Marks**

In triangle  $ABC$ , angle  $BAC$  is  $45^\circ$  and  $ED$  is parallel to  $BC$ . Two right angles are shown.

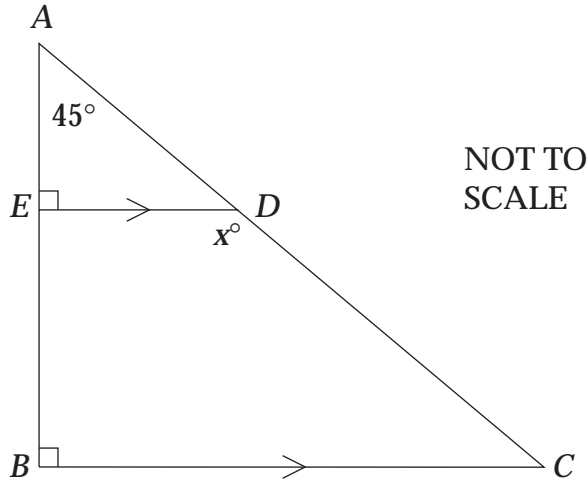

- (a) Calculate the size of  $x^\circ$ . Give a reason for your answer. **2**

.....

.....

.....

.....

- (b) The height of the trapezium  $EDCB$  is three times the height of triangle  $ADE$ . **1**

Complete this statement:

The length of  $BC$  is ..... times the length of  $ED$ .

- (c) The area of triangle  $AED$  is  $50 \text{ cm}^2$ . What is the area of the trapezium  $EDCB$ ? **2**

.....

.....

.....

.....

**Question 83** (5 marks)

**Marks**

The area,  $A$ , of an ellipse is given by  $A = \pi ab$ .

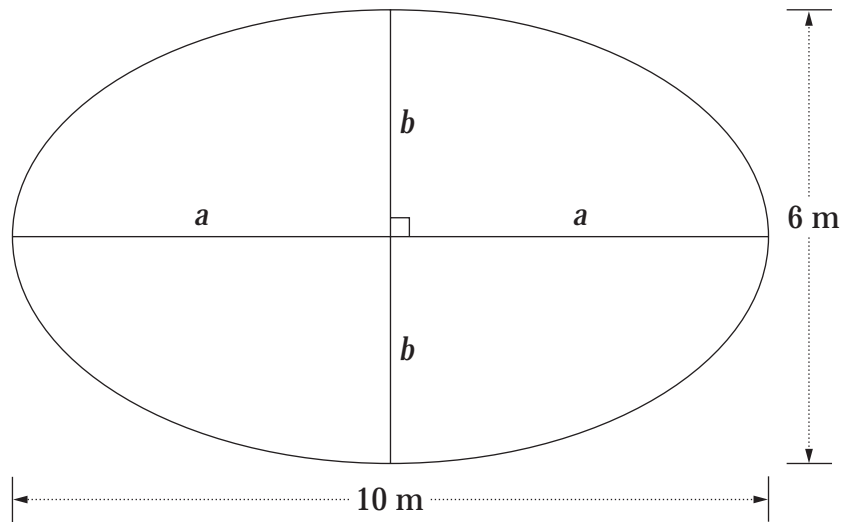

- (a) Show that the area of this ellipse is  $47 \text{ m}^2$ , correct to the nearest square metre. 1

.....  
 .....

- (b) Louise draws a rectangle around the ellipse as shown. 1

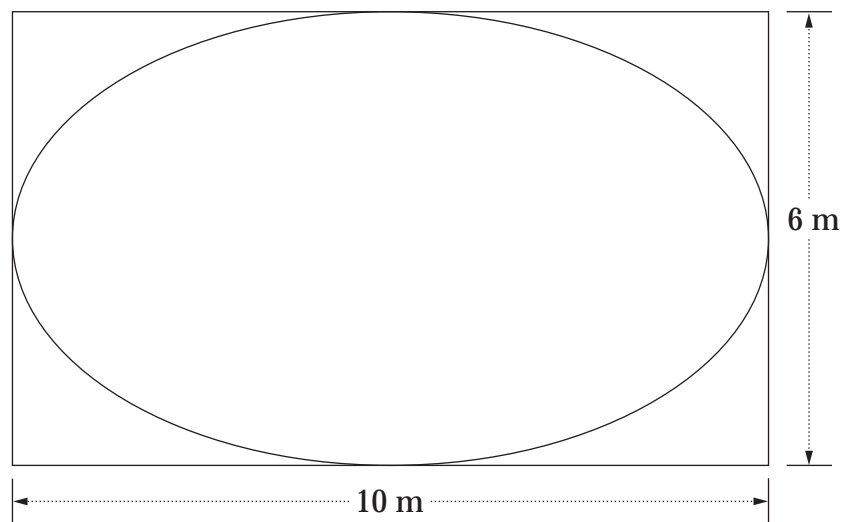

What percentage of the rectangle is covered by the ellipse? (Answer to the nearest whole percent.)

.....  
 .....

Question 83 (continued)

Marks

Louise uses the ellipse and two circles to design a rug. The diagram shows her design, drawn on a number plane.

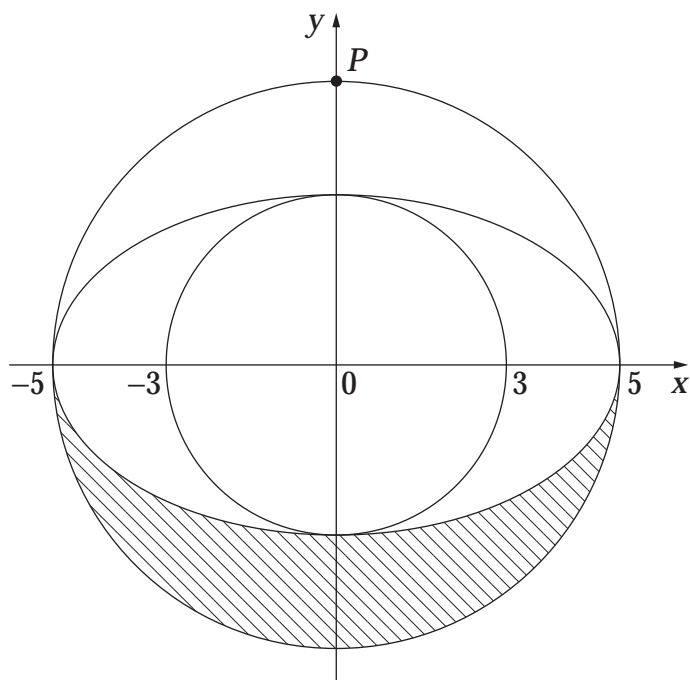

(c) The coordinates of point  $P$  are (....., .....). 1

(d) Calculate the area of the shaded region. 1

.....  
 .....

(e) Louise is binding the circumference of the larger circle with wool. She uses 80 g of wool for every metre. 1

How many grams of wool will she use?

.....  
 .....

**Question 84** (5 marks)

**Marks**

Sharyn is sterilising a bottle to kill bacteria before she puts sauce in it. This table shows the number,  $n$ , of live bacteria in the bottle after  $t$  minutes.

$t$	0	1	2	3	4
$n$	21 870	7 290	2 430	810	

(a) Fill in the missing value in the table, assuming the number pattern continues. 1

(b) How many bacteria were killed in the first two minutes? 1

.....  
 .....

(c) The formula that relates  $t$  to  $n$  is  $n = \square \times \left(\frac{1}{3}\right)^t$ . 1

When  $t = 1$ ,  $n = 7\,290$ . This means:  $7\,290 = \square \times \left(\frac{1}{3}\right)^1$ .

Calculate the value represented by  $\square$ .

.....  
 .....

(d) Circle the graph that best shows the number of live bacteria in the first five minutes. 1

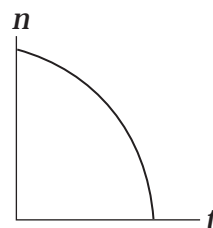
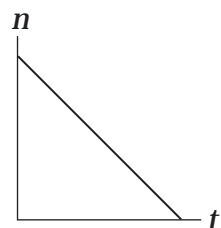
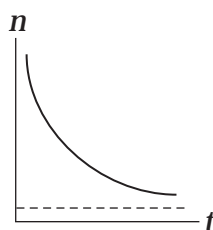
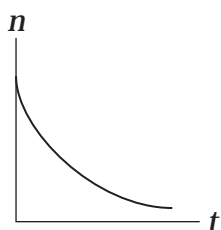

(e) After how many minutes will there first be less than two bacteria alive? 1

.....

**End of test**