

B O A R D O F S T U D I E S
NEW SOUTH WALES

Mathematics General 1

Stage 6

**Draft
Syllabus**

2008

© 2008 Copyright Board of Studies NSW for and on behalf of the Crown in right of the State of New South Wales.

This document contains Material prepared by the Board of Studies NSW for and on behalf of the State of New South Wales. The Material is protected by Crown copyright.

All rights reserved. No part of the Material may be reproduced in Australia or in any other country by any process, electronic or otherwise, in any material form or transmitted to any other person or stored electronically in any form without the prior written permission of the Board of Studies NSW, except as permitted by the *Copyright Act 1968*. School students in NSW and teachers in schools in NSW may copy reasonable portions of the Material for the purposes of bona fide research or study.

When you access the Material you agree:

- to use the Material for information purposes only
- to reproduce a single copy for personal bona fide study use only and not to reproduce any major extract or the entire Material without the prior permission of the Board of Studies NSW
- to acknowledge that the Material is provided by the Board of Studies NSW
- not to make any charge for providing the Material or any part of the Material to another person or in any way make commercial use of the Material without the prior written consent of the Board of Studies NSW and payment of the appropriate copyright fee
- to include this copyright notice in any copy made
- not to modify the Material or any part of the Material without the express prior written permission of the Board of Studies NSW.

The Material may contain third party copyright materials such as photos, diagrams, quotations, cartoons and artworks. These materials are protected by Australian and international copyright laws and may not be reproduced or transmitted in any format without the copyright owner's specific permission. Unauthorised reproduction, transmission or commercial use of such copyright materials may result in prosecution.

The Board of Studies has made all reasonable attempts to locate owners of third party copyright material and invites anyone from whom permission has not been sought to contact the Copyright Officer, ph (02) 9367 8289, fax (02) 9279 1482.

Published by
Board of Studies NSW
GPO Box 5300
Sydney NSW 2001
Australia

Tel: (02) 9367 8111
Fax: (02) 9367 8484
Internet: www.boardofstudies.nsw.edu.au

ISBN 978 174147 8327

2008316

Contents

1	The Higher School Certificate Program of Study.....	5
2	Rationale for Mathematics General 1 and Mathematics General 2 in the Stage 6 Curriculum.....	6
3	Continuum of Learning for Stage 6 Mathematics General 1 Students.....	7
4	Mathematics in Stage 6.....	8
5	Aim.....	11
6	Objectives.....	11
7	Course Structure.....	12
8	Objectives and Outcomes.....	13
	8.1 Table of Objectives and Outcomes.....	13
	8.2 Key Competencies.....	16
9	Preliminary Mathematics General Course Content.....	20

Note: For pages 21-71, refer to the accompanying document *Preliminary Mathematics General Stage 6 Course Content 2008*.

10	HSC Mathematics General 1 Course Content.....	73
	Area of Study 1: Financial Mathematics.....	74
	Area of Study 2: Data Analysis.....	78
	Area of Study 3: Measurement.....	86
	Area of Study 4: Probability.....	92
	Area of Study 5: Algebra and Modelling.....	96
	Focus Study 3: Mathematics and Design.....	102
	Focus Study 4: Mathematics and Household Finance.....	110
	Focus Study 5: Mathematics and the Human Body.....	116
	Focus Study 6: Mathematics and Personal Resource Usage.....	124
11	Course Requirements.....	132
12	Post-school Opportunities.....	133

Continued overleaf

Contents (continued)

13	Assessment and Reporting	134
13.1	Requirements and Advice	134
13.2	Internal Assessment.....	135
13.3	External Examination	135
13.4	Board Requirements for the Internal Assessment Mark in Board Developed Courses	136
13.5	Assessment Components, Weightings and Tasks	137
13.6	HSC External Examination Specifications.....	139
13.7	Summary of Internal and External Assessment	140
13.8	Reporting Student Performance Against Standards.....	140

1 The Higher School Certificate Program of Study

The purpose of the Higher School Certificate program of study is to:

- provide a curriculum structure which encourages students to complete secondary education
- foster the intellectual, social and moral development of students, in particular developing their:
 - knowledge, skills, understanding and attitudes in the fields of study they choose
 - capacity to manage their own learning
 - desire to continue learning in formal or informal settings after school
 - capacity to work together with others
 - respect for the cultural diversity of Australian society
- provide a flexible structure within which students can prepare for:
 - further education and training
 - employment
 - full and active participation as citizens
- provide formal assessment and certification of students' achievements
- provide a context within which schools also have the opportunity to foster students' physical and spiritual development.

2 Rationale for Mathematics General 1 and Mathematics General 2 in the Stage 6 Curriculum

Mathematics is deeply embedded in modern society. From the numeracy skills required to manage personal finances, to making sense of data in various forms, to leading-edge technologies in the Sciences and Engineering, Mathematics provides the framework for interpreting, analysing and predicting, and the tools for effective participation in an increasingly complex society.

The need to interpret the large volumes of data made available through technology draws on skills in logical thought and the ability to check claims and assumptions in a systematic way. Mathematics is the appropriate training ground for the development of these skills and abilities. The thinking required to enhance further the power and usefulness of technology in real-world applications requires advanced mathematical training. The rapid advances in technology experienced in recent years have driven, and been driven by, advances in the discipline of Mathematics.

The development of Mathematics throughout history has been catalysed by its utility in explaining real-world phenomena and its inherent beauty. In this way, the discipline has continued to evolve through a process of observation, conjecture, proof and application.

Effective participation in a changing society is enhanced by the development of mathematical competence in contextualised problem-solving. Experience in such problem-solving is gained by students gathering, analysing and interpreting mathematical information, and applying Mathematics to model situations.

The opportunities for creative thinking, communication and contextualised problem-solving provided by the Mathematics General 1 and Mathematics General 2 courses, assist students to find solutions for the broad range of problems encountered in life beyond secondary schooling.

The purpose of the courses is to provide an appropriate mathematical background for students who wish to enter occupations that require the use of a variety of mathematical and statistical techniques. The direction taken by the courses, in focusing on mathematical skills and techniques that have direct application to everyday activity, contrasts with the more abstract approach taken by the Mathematics Stage 6 calculus-based courses.

The study of the courses provides students with valuable support in a range of concurrent Stage 6 subjects and in fostering development of mathematical skills and techniques that assist students who undertake associated research and projects.

The courses provide a strong foundation for vocational pathways, either in the workforce or in further training. In the case of the higher course, Mathematics General 2, this includes a strong foundation for university courses in the humanities, nursing and paramedical sciences.

3 Continuum of Learning for Stage 6 Mathematics General 1 Students

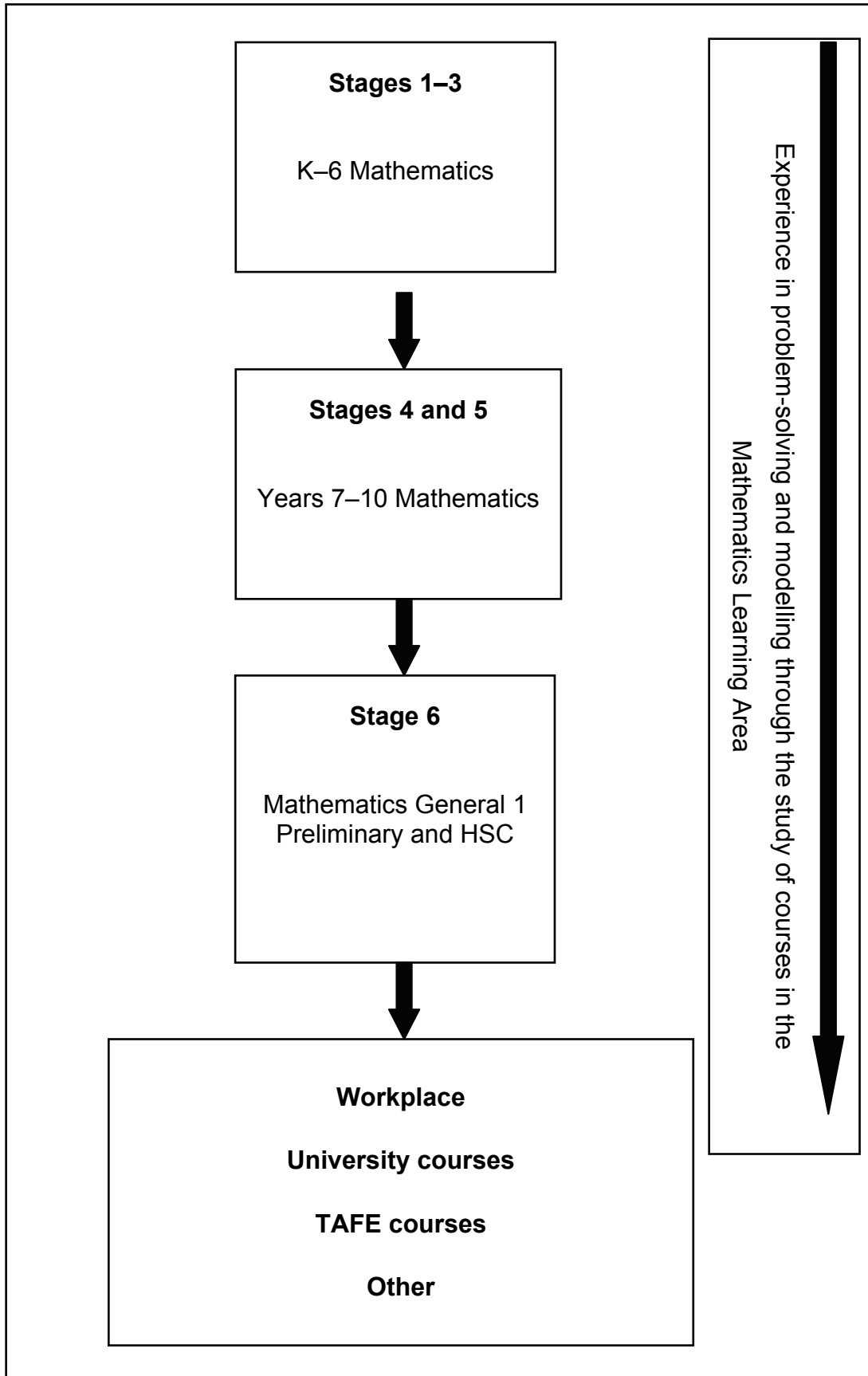

4 Mathematics in Stage 6

There are five Board-developed Mathematics courses of study for the Higher School Certificate: (in increasing order of difficulty) Mathematics General 1, Mathematics General 2, Mathematics Advanced, Mathematics Extension 1, and Mathematics Extension 2.

Students of the Mathematics General 1 and Mathematics General 2 courses study a common Preliminary course, Preliminary Mathematics General, leading to the HSC Mathematics General 1 and HSC Mathematics General 2 courses.

Mathematics Advanced consists of the courses Preliminary Mathematics Advanced and HSC Mathematics Advanced. Students studying one or both Extension courses study Preliminary Mathematics Extension course before undertaking the study of HSC Mathematics Extension 1, or HSC Mathematics Extension 1 and HSC Mathematics Extension 2.

The following assumptions and recommendations regarding learning from Stage 5 Mathematics, typically undertaken by students in Years 9 and 10, are provided in relation to the study of the suite of Stage 6 courses. It is assumed that students who intend to study the Stage 6 Mathematics General 1 course have experienced all of the Stage 5.1 content. For students who intend to study the Stage 6 Mathematics General 2 course, it is recommended that they experience at least some of the Stage 5.2 content, particularly the *Patterns and Algebra* topics and *Trigonometry*, if not all of the content. For students who intend to study the Stage 6 Mathematics Advanced course, it is recommended that they experience the topics *Real Numbers*, *Algebraic Techniques* and *Coordinate Geometry* as well as at least some of *Trigonometry* and *Deductive Geometry* from 5.3 (identified by §), if not all of the content. For students who intend to study the Stage 6 Mathematics Extension 1 course, it is recommended that they experience the optional topics (identified by #) *Curve Sketching and Polynomials*, *Functions and Logarithms*, and *Circle Geometry*.

The Preliminary and HSC course components undertaken by students who study Mathematics General 1, Mathematics General 2, or Mathematics Advanced, and by students who study Stage 6 Mathematics to Mathematics Extension 1 or Mathematics Extension 2 level, are illustrated on the following pages.

Mathematics General 1 – Preliminary and HSC course components

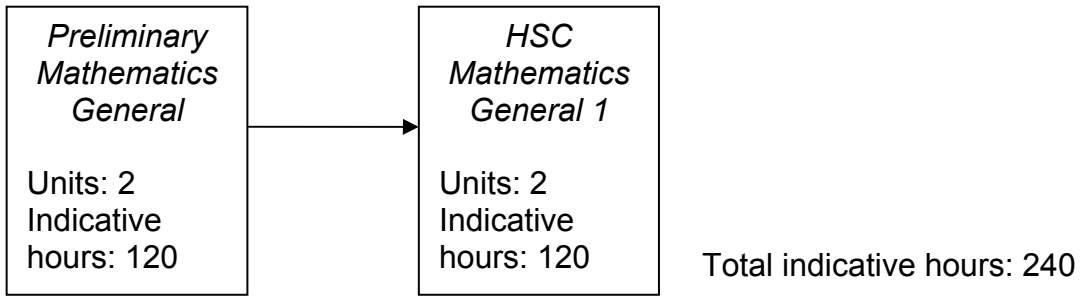

Mathematics General 2 – Preliminary and HSC course components

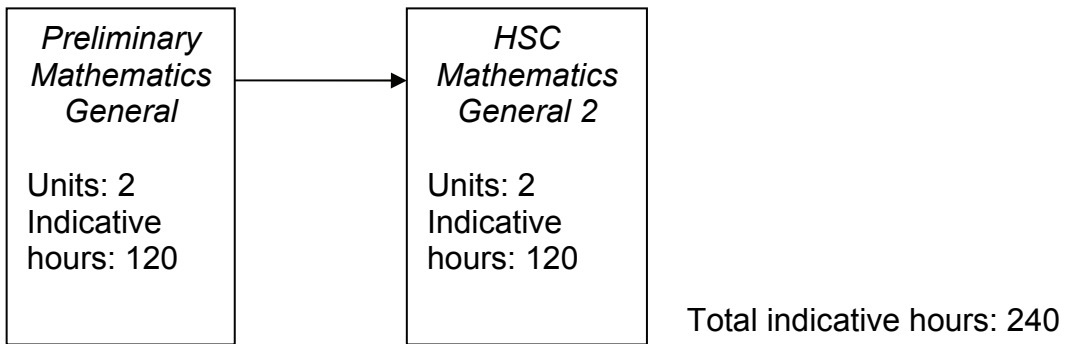

Mathematics Advanced – Preliminary and HSC course components

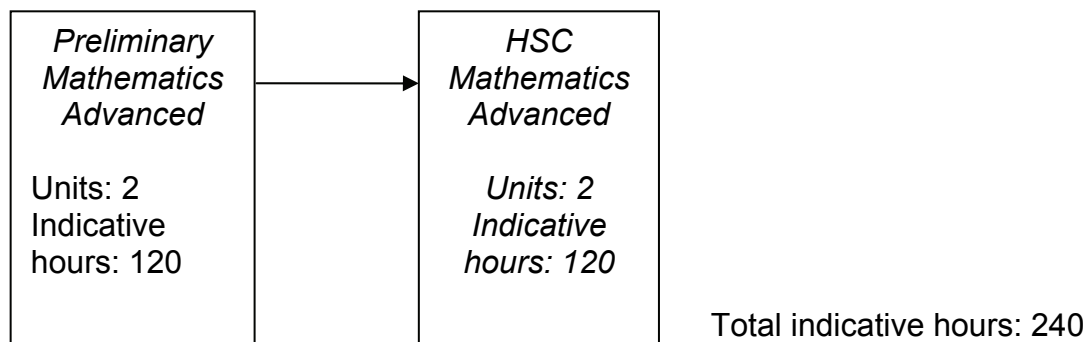

Preliminary and HSC course components undertaken by students studying Stage 6 Mathematics to Mathematics Extension 1 level

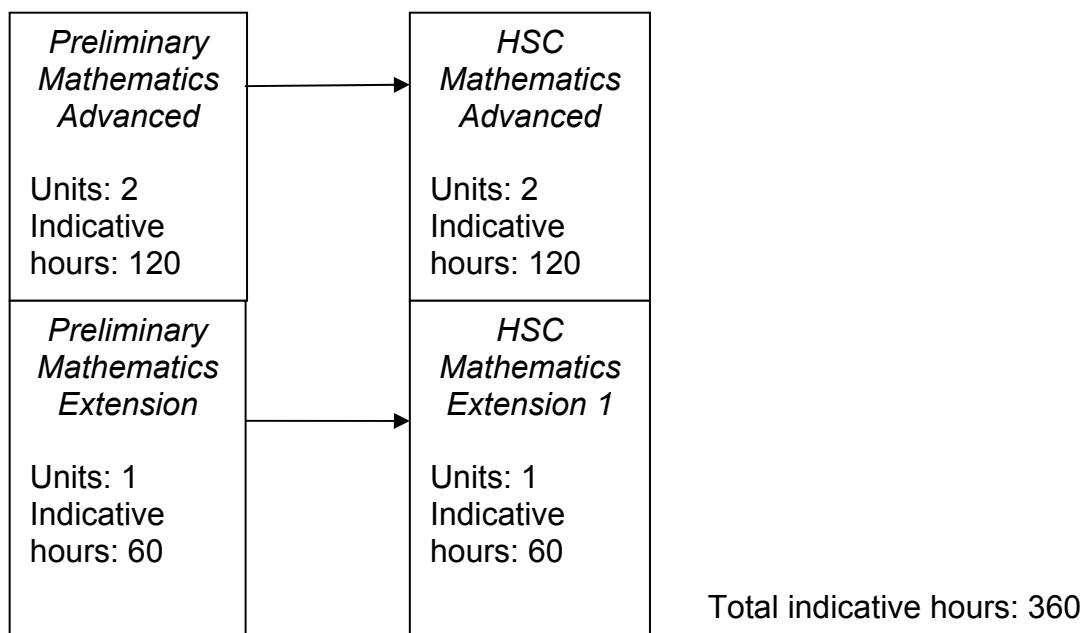

Preliminary and HSC course components undertaken by students studying Stage 6 Mathematics to Mathematics Extension 2 level

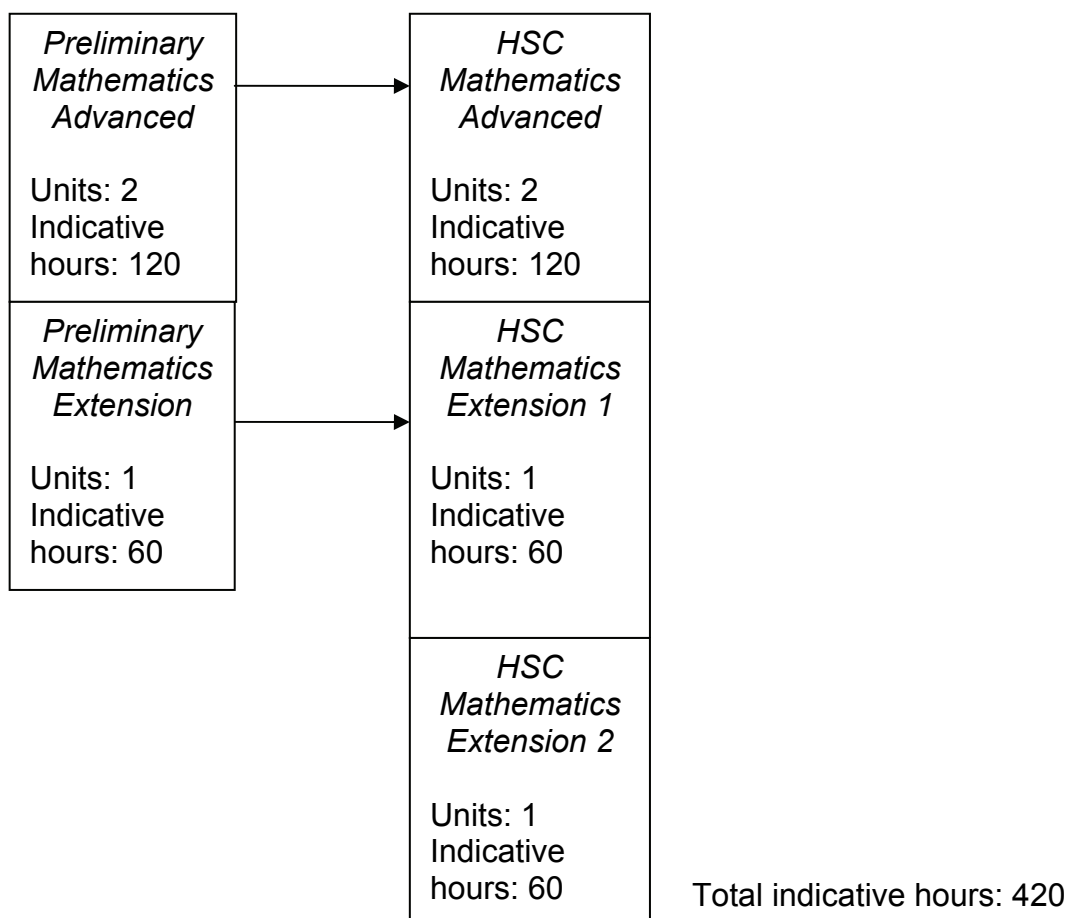

5 Aim (Mathematics General 1, Mathematics General 2 courses)

The Mathematics General 1 and Mathematics General 2 courses are designed to promote the development of knowledge, skills and understanding in areas of Mathematics that have direct application to the broad range of human activity.

Students will learn to use a range of techniques and tools, including relevant technologies, in order to develop solutions to a wide variety of problems relating to their present and future needs and aspirations.

6 Objectives (Mathematics General 1, Mathematics General 2 courses)

Knowledge, skills and understanding

Students will develop:

- the ability to apply reasoning, and the use of appropriate language, in the evaluation and construction of arguments and models based on mathematical and statistical concepts
- the ability to use concepts and apply techniques to the solution of problems in algebra and modelling, measurement, financial mathematics, data analysis, and probability
- the ability to use mathematical skills and techniques, aided by appropriate technology, to organise information and interpret practical situations
- the ability to interpret and communicate Mathematics in a variety of written and verbal forms, including diagrams and statistical graphs.

Values and attitudes

Students will develop:

- appreciation of the relevance of Mathematics.

7 Course Structure

The following schematic view illustrates the structure of the Mathematics General 1 course, through its Preliminary and HSC course components.

Preliminary Course	HSC Course
<p>Financial Mathematics PMG1 Earning money PMG2 Investing money PMG3 Taxation</p> <p>Data Analysis PMG4 Statistics and society, data collection and sampling PMG5 Displaying single data sets PMG6 Summary statistics</p> <p>Measurement PMG7 Units of measurement and applications PMG8 Applications of area and volume PMG9 Similarity of two-dimensional figures, right-angled triangles</p> <p>Probability PMG10 The language of chance PMG11 Relative frequency and probability</p> <p>Algebra and Modelling PMG12 Basic algebraic skills PMG13 Modelling linear relationships</p> <p>Focus Studies 1. Mathematics and Communication 2. Mathematics and Driving</p>	<p>Financial Mathematics MG1.1 Credit cards</p> <p>Data Analysis MG1.2 Interpreting sets of data MG1.3 Distributions MG1.4 Working with statistics</p> <p>Measurement MG1.5 Right-angled triangles (Review) MG1.6 Further applications of area and volume</p> <p>Probability MG1.7 Multi-stage events and applications of probability</p> <p>Algebra and Modelling MG1.8 Further algebraic skills MG1.9 Modelling with functions</p> <p>Focus Studies 3. Mathematics and Design 4. Mathematics and Household Finance 5. Mathematics and the Human Body 6. Mathematics and Personal Resource Usage</p>

8 Objectives and Outcomes

8.1 Table of Objectives and Outcomes

Objectives	Preliminary Outcomes	HSC Outcomes Mathematics General 1	HSC Outcomes Mathematics General 2
Students will develop the ability to:	A student:	A student:	A student:
apply reasoning, and the use of appropriate language, in the evaluation and construction of arguments based on mathematical and statistical concepts	PG1 uses Mathematics and statistics to compare alternative solutions to contextual problems PG2 represents information in symbolic, graphical and tabular forms	HG1.1 uses Mathematics and statistics to evaluate and construct arguments in a range of familiar contexts HG1.2 analyses representations of data in order to make predictions	HG2.1 uses Mathematics and Statistics to evaluate and construct arguments in a range of familiar and unfamiliar contexts HG2.2 analyses representations of data in order to make inferences, predictions and conclusions
use concepts and apply techniques to the solution of problems in algebra and modelling, measurement, financial mathematics, data analysis, and probability (Note: further outcomes related to this objective on page 14)	PG3 represents the relationships between changing quantities in algebraic and graphical form PG4 performs calculations in relation to two-dimensional and three-dimensional figures	HG1.3 makes predictions about everyday situations based on simple mathematical models HG1.4 analyses two-dimensional and three-dimensional models to solve practical problems	HG2.3 makes predictions about situations based on mathematical models HG2.4 analyses two-dimensional and three-dimensional models to solve practical problems, including those involving spheres and non-right-angled triangles

Objectives	Preliminary Outcomes	HSC Outcomes Mathematics General 1	HSC Outcomes Mathematics General 2
<p>Students will develop the ability to: use concepts and apply techniques to the solution of problems in algebra and modelling, measurement, financial mathematics, data analysis, and probability</p> <p>(Note: further outcomes related to this objective on page 13)</p>	<p>A student:</p> <p>PG5 demonstrates awareness of issues in practical measurement, including accuracy, and the choice of relevant units</p> <p>PG6 models financial situations relevant to the student's current life using appropriate tools</p> <p>PG7 determines an appropriate form of organisation and representation of collected data</p> <p>PG8 performs simple calculations in relation to the likelihood of familiar events</p>	<p>A student:</p> <p>HG1.5 interprets the results of measurements and calculations and makes judgements about reasonableness, including conversion to appropriate units</p> <p>HG1.6 makes informed decisions about financial situations they are likely to encounter post-school</p> <p>HG1.7 develops and carries out statistical processes to answer questions which she/he and others have posed</p> <p>HG1.8 solves problems involving uncertainty using basic counting techniques</p>	<p>A student:</p> <p>HG2.5 interprets the results of measurements and calculations and makes judgements about reasonableness, including the degree of accuracy of measurements and calculations and conversion to appropriate units</p> <p>HG2.6 makes informed decisions about financial situations including annuities and loan repayments</p> <p>HG2.7 answers questions requiring statistical processes and knowledge, including the use of the normal distribution, and the correlation of bivariate data</p> <p>HG2.8 solves problems requiring knowledge of counting techniques, multi-stage probability and financial expectation</p>

Objectives	Preliminary Outcomes	HSC Outcomes Mathematics General 1	HSC Outcomes Mathematics General 2
Students will develop the ability to:	A student:	A student:	A student:
use mathematical skills and techniques, aided by appropriate technology, to organise information and interpret practical situations	PG9 uses appropriate technology to organise information from a limited range of practical and everyday contexts	HG1.9 chooses and uses appropriate technology to organise information from a range of practical and everyday contexts	HG2.9 chooses and uses appropriate technology to locate and organise information from a range of contexts
interpret and communicate Mathematics in a variety of written and verbal forms, including diagrams and statistical graphs	PG10 justifies his/her response to a given problem using appropriate mathematical terminology	HG1.10 uses mathematical argument and reasoning to evaluate conclusions drawn from other sources, communicating a position clearly to others	HG2.10 uses mathematical argument and reasoning to evaluate conclusions drawn from other sources, communicating a position clearly to others, and justifies a response
Values and attitudes			
Students will develop:	A student	A student	A student
appreciation of the relevance of Mathematics	PG/VA develops a positive attitude to Mathematics and appreciates its capacity to provide enjoyment and recreation	HG1/VA appreciates the importance of Mathematics in her/his own life and its usefulness in contributing to society	HG2/VA appreciates the importance of Mathematics in her/his own life and its usefulness in contributing to society

8.2 Key Competencies

Mathematics General 1 provides a context within which to develop general competencies considered essential for the acquisition of effective, higher-order thinking skills necessary for further education, work and everyday life.

Key competencies are embedded in the *Mathematics General 1 Stage 6 Syllabus* to enhance student learning. The key competencies are developed through the methodologies of the syllabus and through classroom pedagogy. The key competencies of collecting, analysing and organising information and communicating ideas and information, reflect core processes of mathematical inquiry undertaken by students as they engage with the various syllabus topics. Students work as individuals and as members of groups to engage with applications and modelling tasks. Through this, the key competencies of planning and organising activities and working with others and in teams are developed. At all levels of the course, students are developing the key competency of using mathematical ideas and techniques. Through the advice provided on the selection and use of appropriate technology, students can develop the key competency of using technology. Finally, students' continual involvement with seeking solutions to problems, both large and small, contributes towards their development of the key competency of solving problems.

Presentation of Content

The course content for the Mathematics General 1 course (and for the Mathematics General 2 course) is organised into *Areas of Study* and *Focus Studies*, with each of the Areas of Study, Financial Mathematics, Data Analysis, Measurement, Probability, and Algebra and Modelling divided into *topics* that lead into the Focus Studies.

The Focus Studies are designed to be programmed over a continuous time period as they provide students with the opportunity to apply and develop further the knowledge, skills and understanding initially developed in the Areas of Study, as well as introducing some new mathematical content. It is intended that students develop, through the Focus Studies, the capacity to integrate their knowledge, skills and understanding across the Areas of Study.

Students of the Mathematics General 1 and Mathematics General 2 courses study a common Preliminary course, Preliminary Mathematics General, which includes the Focus Studies: Mathematics and Communication, and Mathematics and Driving.

There are four Focus Studies in the HSC course for Mathematics General 1: Mathematics and Design, Mathematics and Household Finance, Mathematics in the Human Body, and Mathematics and Personal Resource Usage. (There are two Focus Studies in the HSC course for Mathematics General 2: Mathematics and Health, and Mathematics and Resources.)

The course content for the Mathematics General 1 course (and for the Mathematics General 2 course) is presented in the following format:

1. Initial facing pages for Area of Study or Focus Study

Name of an Area of Study or Name of Focus Study

A brief summary of the content/purpose of the Area of Study, or the content/purpose of the Focus Study.

Assumed Stage 5.1 outcomes [This section only appears for topics from an Area of Study in the Preliminary course.]

Outcomes from Stage 5.1 of *Mathematics Years 7–10 Syllabus*, that students should have achieved to engage successfully with the Area of Study or Focus Study.

Prerequisite topics [This section only appears for a Focus Study.]

Topics that students should have studied to engage successfully with the Focus Study.

Outcomes addressed

A list of the course outcomes addressed in the study of the topics from an Area of Study, or addressed in the study of a Focus Study.

Content summary

A list of the topics studied within an Area of Study, or a list of the topics studied within a Focus Study.

Terminology

A list of key words and/or phrases met in an Area of Study or Focus Study, some of which may be new to students.

Use of technology

Advice about the nature and use of technology that is appropriate to the topic(s) from an Area of Study, or to a Focus Study.

Area of Study (or Focus Study) notes

Notes relevant to teaching particular aspects of the topics from an Area of Study, or Focus Study.

2. Subsequent facing pages for Area of Study of Focus Study

Name of topic

A brief summary of the content/purpose of the topic.

Outcomes addressed

A list of the course outcomes addressed in the study of the topic.

Students develop the following knowledge, skills and understanding

The mathematical content to be addressed in the topic.

Applications and considerations

The provision of examples indicating the range and style of applications used to introduce and illustrate the mathematical content of the topic, as well as important considerations for learning and teaching the topic.

Use of technology

(a) in learning and teaching, and school-based assessment

The appropriateness, viability and level of use of different types of technology in the learning and teaching of courses within the Mathematics Key Learning Area are decisions for students, teachers and schools. However, the use of technology is encouraged in the learning and teaching, and school-based assessment, where appropriate, of courses within the learning area. In accordance with the Broad Directions from the first phase of the development of the revised Stage 6 Mathematics courses, the use of technology with capabilities beyond the level of scientific calculators is encouraged in the learning and teaching, and school-based assessment, of the courses, ie Mathematics General 1, Mathematics General 2, Mathematics Advanced, Mathematics Extension 1 and Mathematics Extension 2.

Each of the five Stage 6 syllabuses contain advice and suggestions in relation to the use of a range of technology in the 'Use of technology' and 'Applications and considerations' sections within the course content. The *Mathematics General 1 Syllabus* provides a range of opportunities for the use of calculators and computer software packages in learning and teaching. This includes opportunities to utilise the graphing functions and financial and statistical capabilities of calculators, spreadsheets, and dynamic geometry and statistics software packages.

(b) in the HSC examinations

In the HSC examinations for the revised Stage 6 Board-developed Mathematics courses, candidates will be permitted to use only calculators manufactured to meet a clear set of Board-prescribed calculator functions and capabilities. These functions and capabilities will be consistent with and support the knowledge and skills that students should be able to demonstrate after completing a course, or courses. The list of functions and capabilities are being determined in parallel with the development of the content for the courses and will be completed in conjunction with the finalisation of the courses following consultation on the draft syllabuses.

9 Preliminary Mathematics General Course Content

Note: For pages 21-71, refer to the accompanying document *Preliminary Mathematics General Stage 6 Course Content 2008*.

Hours shown are indicative only.

Areas of Study 80 hours

Financial Mathematics

- PMG1 Earning money
- PMG2 Investing money
- PMG3 Taxation

Data Analysis

- PMG4 Statistics and society, data collection and sampling
- PMG5 Displaying single data sets
- PMG6 Summary statistics

Measurement

- PMG7 Units of measurement and applications
- PMG8 Applications of area and volume
- PMG9 Similarity of two-dimensional figures, right-angled triangles

Probability

- PMG10 The language of chance
- PMG11 Relative frequency and probability

Algebra and Modelling

- PMG12 Basic algebraic skills
- PMG13 Modelling linear relationships

Focus Studies 40 hours

- 1. Mathematics and Communication (20 hours)
- 2. Mathematics and Driving (20 hours)

Total indicative hours 120 hours

[The next page is 73]

10 HSC Mathematics General 1 Course Content

Hours shown are indicative only.

Areas of Study **40 hours**

Financial Mathematics

MG1.1 Credit cards

Data Analysis

MG1.2 Interpreting sets of data

MG1.3 Distributions

MG1.4 Working with statistics

Measurement

MG1.5 Right-angled triangles (Review)

MG1.6 Further applications of area and volume

Probability

MG1.7 Multi-stage events and applications of probability

Algebra and Modelling

MG1.8 Further algebraic skills

MG1.9 Modelling with functions

Focus Studies **80 hours**

3. **Mathematics and Design** **(20 hours)**

4. **Mathematics and Household Finance** **(20 hours)**

5. **Mathematics and the Human Body** **(20 hours)**

6. **Mathematics and Personal Resource Usage** **(20 hours)**

Total indicative hours **120 hours**

Area of Study 1: Financial Mathematics

In this Area of Study, students read and interpret credit card statements, and perform financial calculations.

Outcomes addressed

A student:

- HG1.1 uses Mathematics and statistics to evaluate and construct arguments in a range of familiar contexts
- HG1.2 analyses representations of data in order to make predictions
- HG1.6 makes informed decisions about financial situations they are likely to encounter post-school
- HG1.9 chooses and uses appropriate technology to organise information from a range of practical and everyday contexts
- HG1.10 uses mathematical argument and reasoning to evaluate conclusions drawn from other sources, communicating a position clearly to others

Content summary

- MG1.1 Credit cards

Terminology

annual fee	credit rating
annual interest rate	debit
billing cycle	debit card
credit	interest-free period
credit card	

Use of technology

Students will be required to create a spreadsheet to simulate a credit card statement, including the calculation of the interest and minimum balance payable.

Area of Study notes

Students should have access to actual financial information and products, eg some actual credit card statements should be used in learning and assessment.

Students will study additional content related to Financial Mathematics in the *Mathematics and Household Finance* Focus Study.

MG1.1: Credit cards

This topic focuses on the Mathematics of using credit cards as a method of payment for goods and services. Students learn to read and interpret credit card statements, and to calculate the interest payable, the account balance, and the fees payable.

Outcomes addressed

HG1.1, HG1.2, HG1.6, HG1.9, HG1.10

Students develop the following knowledge, skills and understanding

- reading and interpreting credit card statements
- identification of the various fees associated with credit card usage, including interest charges, annual card fees, late payment fees, etc, and how they are calculated
- calculation of credit-card payments, including fees, charges, rates, and interest-free periods
- expressing a percentage annual interest rate as a daily rate both in percentage and decimal form
- application of the simple-interest formula $I = Prn$, where r is the interest rate expressed as a decimal, to calculate interest for one billing cycle
- comparison of the difference between credit cards and debit cards.

Applications and considerations

- Students should have access to actual credit card statements issued by major Australian financial institutions. Details that could identify an individual need to be changed sufficiently, or deleted, to protect privacy. These details include, but are not limited to, names, account numbers, and addresses.
- For interest calculations, assume that interest is calculated on the daily outstanding account balance and is applied at the end of the statement period. The daily interest rate is used for this calculation. Note that the daily interest rate is the Annual Percentage Rate divided by 365. Use the simple interest formula $I = Prn$ where r is the interest rate expressed as a decimal, eg an annual rate of 16.5% becomes a daily rate of 0.000 452 (to 3 significant figures).
- Students calculate missing values on a credit card statement, given the following information: annual interest rate, opening balance, at least three purchase transactions (item, date, amount) and two cash advances (date and amount), at least two repayments to card (date and amount). Students should write down the working for the calculation of the interest charge, final balance, and minimum payment due. Refer to support material for examples.
- Students create a credit card statement using an electronic spreadsheet.
- Students complete a partially completed credit card statement.
- Students compare, by making calculations, the costs of credit cards from different lenders. This should include consideration of the interest rates offered and other charges.
- Students access suitable websites that provide information on credit cards and calculations.

Area of Study 2: Data Analysis

In this Area of Study, students use various data displays, and apply measures of location and measures of spread. They also investigate common statistical distributions and their associated properties, and misconceptions in statistical reasoning.

Outcomes addressed

A student:

- HG1.1 uses Mathematics and statistics to evaluate and construct arguments in a range of familiar contexts
- HG1.2 analyses representations of data in order to make predictions
- HG1.3 makes predictions about everyday situations based on simple mathematical models
- HG1.7 develops and carries out statistical processes to answer questions which she/he and others have posed
- HG1.9 chooses and uses appropriate technology to organise information from a range of practical and everyday contexts
- HG1.10 uses mathematical argument and reasoning to evaluate conclusions drawn from other sources, communicating a position clearly to others.

Content summary

- MG1.2 Interpreting sets of data
- MG1.3 Distributions
- MG1.4 Working with statistics

Terminology

area chart	skewed distribution
bi-modal distributions	skewness
correlation	standardised score
correlation coefficient	symmetric distribution
line of best fit	trend
normal distribution	uniform distribution
outlier	z -score

Use of technology

Students should use appropriate technology to construct frequency tables, measures of location, and measures of spread.

Students should use appropriate technology to generate box-and-whisker plots, radar charts, area charts, and scatterplots.

Students should use appropriate technology to determine a line of fit and correlation coefficients.

Area of Study notes

Real data should be used in the teaching of this Area of Study. Online data sources include the Australian Bureau of Statistics (ABS) website.

In the Focus Study Mathematics and the Human Body, students further investigate normal distributions, and correlation, in practical contexts.

MG1.2: Interpreting sets of data

The principal focus of this topic is the use of data displays, measures of location, and measures of spread, to summarise and interpret one or more sets of data.

Outcomes addressed

HG1.1, HG1.2, HG1.7, HG1.9, HG1.10

Students develop the following knowledge, skills and understanding

- identifying measures of location: mean and median
- identifying measures of spread: range, interquartile range, and standard deviation
- investigating outliers in small data sets and their effects on the mean, median and mode
- describing the general shape of a graph or display that represents a given data set, eg in terms of smoothness, symmetry, number of modes
- making judgements about data, based on observed features of a display, such as shape and skewness
- displaying data in double (back-to-back) stem-and-leaf plots
- displaying data in two box-and-whisker plots drawn on the same scale
- displaying two sets of data on a radar chart
- preparing an area chart to illustrate and compare different sets of data over time (see example at end of topic)
- using multiple displays to describe and interpret the relationships between data sets
- interpreting data presented in two-way table form, eg male/female versus exercise/no exercise
- comparing the summary statistics for two sets of data.

Applications and considerations

- Prepare a stem-and-leaf plot from collected data. Use it to decide whether clustering is present, whether the shape of the display indicates any skewness of scores, or if there is any other tendency in the data.
- Investigate population pyramid histograms.
- Students could use summary statistics and statistical displays to compare related pairs of data sets to decide, informally, whether they could have been drawn from the same population, or whether they appear to be from different populations. The following (indicative) pairs of data sets could be considered:
 - home scores versus away scores in national sporting competitions
 - ages of Oscar-winning male actors versus ages of Oscar-winning female actors
 - blood pressure of males versus that of females
 - height of male students versus height of female students (restricted age range)
 - customer waiting times on two different days of the week at a fast-food outlet
 - monthly rainfall in mm for different cities or regions, eg on average does it rain more in Melbourne than in Sydney? Is it a significant difference? Students could discuss what is meant by ‘significant’ in this context.
 - population by age bands for different countries or regions.
- Given data on a particular population in a table, such as the one shown below, answer questions like ‘What percentage of the women in this survey are smokers?’ ‘What percentage of smokers in this survey are women?’ Discuss the difference between these questions. Under what circumstances would the percentages be the same?

	men	women	TOTALS
smokers	4027	4426	8453
non-smokers	8321	7462	15 783
TOTALS	12 348	11 888	24 236

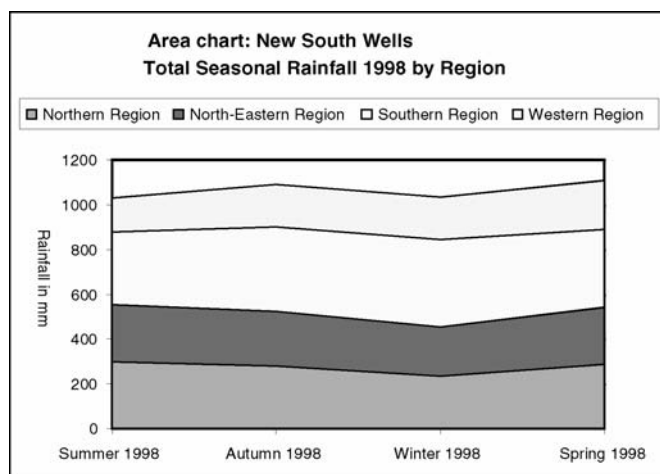

MG1.3: Distributions

In this topic, students learn to recognise and interpret properties of common statistical distributions.

Outcomes addressed

HG1.1, HG1.2, HG1.3, HG1.7, HG1.9, HG1.10

Students develop the following knowledge, skills and understanding

- recognising and describing in general terms different distributions of data, including normal, skewed, uniform, symmetric, and bi-modal distributions
- giving examples of data sets that are normal, skewed, uniform, symmetric, or bi-modal
- for a given histogram, describing the shape of its distribution and how the shape relates to the associated population or sample
- identifying the properties of data that are normally distributed, ie
 - the mean, median and mode are equal
 - if represented by a histogram, the resulting frequency graph is 'bell shaped'
- describing the use of standard deviation as a measure of spread
- solving problems involving interpretation of the standard deviation, where the value of the standard deviation is given.

Applications and considerations

- Students should look at actual data displaying each distribution type, eg average income per day for the world population is a bi-modal distribution.
- An example of a uniform distribution would be the frequency of each number occurring when rolling a die 5000 times. A probability simulation program could be used to generate the data.
- Construction of a graph of the height of each member in a basketball team could be used to illustrate skewness.
- When constructing a graph of the weight of a team of rowers what does the inclusion of the cox do to the weight of a team of rowers.

MG1.4: Working with statistics

In this topic, students learn to recognise and interpret common misconceptions in statistical reasoning.

Outcomes addressed

HG1.1, HG1.2, HG1.3, HG1.7, HG1.9, HG1.10

Students develop the following knowledge, skills and understanding

- describing common misconceptions in statistical reasoning including:
 - misconceptions involving averages
 - interpreting percentage change when the size of the population is small compared to a larger population
 - misconceptions about sample size
 - ‘the gambler’s fallacy’, eg after a run of heads when tossing a fair coin, a tail is more likely to occur on the next toss
- estimating the likelihood of events using a sample, based on how closely the sample matches the parent population
- understanding that a high degree of correlation does not imply causality.

Applications and considerations

- Examples relating to ‘interpreting percentage change when the size of the population is small compared to a larger population’, include

In January 2007 there was a 400% decrease in road deaths in the Northern Territory compared to January 2006, whereas in NSW there was only a 39% decrease when comparing the same periods. In fact there were five road deaths in the Northern Territory in January 2006 compared to one road death in January 2007. This example shows that care needs to be taken when making comparisons between States/Territories as the base populations are very different.

Source of data: *Australian Transport Safety Bureau*

- In relation to misconceptions about sample size, students need to be aware that a well-chosen sample can effectively represent a population even if the ratio of sample size to population size is small.
- A number of different situations relating to ‘the gambler’s fallacy’ could be investigated, eg when tossing coins, it is common for people to believe that the sequence HTHHTTH is a more likely outcome than HHHHHTT.
- There are online calculators which will randomly simulate trials to investigate the likelihood of two people in the class sharing the same birthday. The investigation should begin with students collecting data for the class and then extend it to other classes before using the simulation. This simulation could be repeated numerous time for large samples illustrate proportional reasoning. Further extension would involve having student write their own simulation program which randomly generates the dates and records the number of matches using a spreadsheet.
- ‘Fair games’ could be designed by students and played to investigate the outcome.
- Give explanations for the following research findings:
 - children with bigger feet spell better
 - nations that add fluoride to water have higher incidences of cancer
 - there are more motor vehicle accidents at moderate speed than at high speed.

Area of Study 3: Measurement

In this Area of Study, students extend and apply their knowledge and skills in relation to area, perimeter, and surface area, to more complex figures. They also solve a range of practical problems involving right-angled triangles.

Outcomes addressed

A student:

- HG1.3 makes predictions about everyday situations based on simple mathematical models
- HG1.4 analyses two-dimensional and three-dimensional models to solve practical problems
- HG1.5 interprets the result of measurements and calculations and makes judgements about reasonableness, including conversions to appropriate units
- HG1.9 chooses and uses appropriate technology to organise information from a range of practical and everyday contexts
- HG1.10 uses mathematical argument and reasoning to evaluate conclusions drawn from other sources, communicating a position clearly to others.

Content summary

- MG1.5 Right-angled triangles (Review)
- MG1.6 Further applications of area and volume

Terminology

adjacent	Pythagorean triad
angle of depression	quadrant
angle of elevation	sector
annulus	Simpson's rule
cosine	sine
hypotenuse	tangent
opposite	trigonometry

Use of technology

Teachers and students can use the internet to obtain suitable maps and plans. Google Maps is a useful resource from which to obtain maps and scaled aerial photographs, and for calculating distances on land.

Area of Study notes

Students should be encouraged to 'estimate and check' to determine if results are reasonable. This is a skill that should be reinforced throughout this Area of Study.

Learning should be supported through access to industry-standard house plans and maps.

MG1.5: Right-angled triangles (Review)

The principal focus of this topic is the solution of practical problems involving right-angled triangles, using Pythagoras' theorem and trigonometry.

Outcomes addressed

HG1.4, HG1.5, HG1.9, HG1.10

Students develop the following knowledge, skills and understanding

- using Pythagoras' theorem to:
 - determine whether or not a triangle is right-angled
 - solve problems based on single right-angled triangles
 - calculate perimeters of irregularly-shaped blocks of land
- using Pythagorean triads
 - recognising whether three integers form a Pythagorean triad
 - determining whether a triangle is right-angled through consideration of Pythagorean triads
 - finding the unknown side in a right-angled triangle using Pythagorean triads
- using right-angled trigonometry to solve practical problems
- determining the reasonableness of an answer by drawing a diagram that is roughly to scale.

Applications and considerations

- Pythagorean triads used in problems should include, but not be limited to, the following: 3, 4, 5; 6, 8, 10; 5, 12, 13; 7, 24, 25; and 9, 40, 41.
- Sample problems involving Pythagorean triads include:
 - By considering Pythagorean triads, find the value of C .

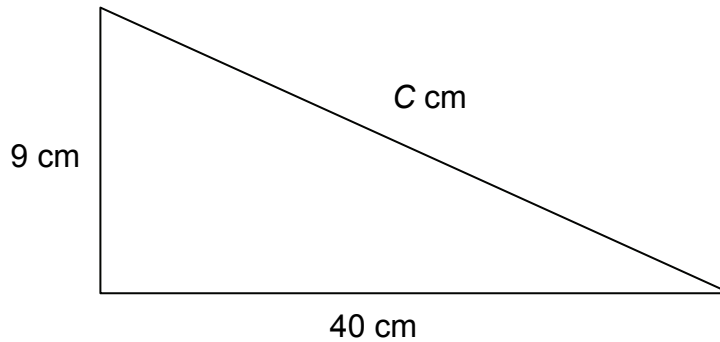

- Determine whether the following integers form a Pythagorean triad: 11, 60, 61.
- Students could research information and write a brief report on Pythagorean triads.
- As a modelling task, students investigate whether a multiple of a Pythagorean triad forms a new Pythagorean triad.
- Students can use or draw diagrams drawn roughly to scale in determining the reasonableness of an answer, eg students could use the diagram below to check the reasonableness of an answer of 45° .

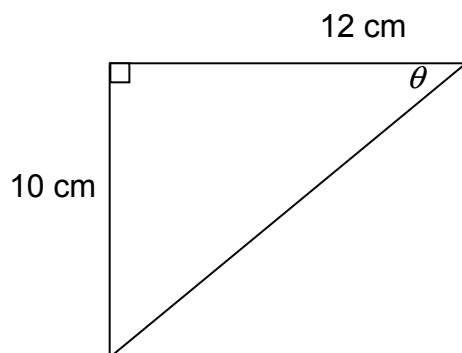

MG1.6: Further applications of area and volume

The principal focus of this topic is to extend the work commenced in PMG8 Applications of area and volume to include surface area of complex figures, and the use of approximations in calculating area and volume of irregular figures.

Outcomes addressed

HG1.3, HG1.4, HG1.5, HG1.9, HG1.10

Students develop the following knowledge, skills and understanding

- calculation of the areas of circles, annuluses, and parts of a circle (quadrant, sector), using appropriate formulae
- calculation of the areas of composite figures which are constructed from squares, rectangles, triangles, and circles
- application of Simpson's rule over three equally-spaced points, ie one application (problems involving five points should be treated using two applications)
- calculation of the external surface area of a sphere, cube, rectangular prism, and closed cylinder
- calculation of the volume of right prisms with an irregular base, where the area of the base is known
- calculation of the volume of an annular cylinder, ie a tube or ring, given the area of the annular base
- estimating and checking to determine if results are reasonable.

Applications and considerations

- Design the shape and dimensions of a container that would have a given capacity, given the purpose and use of the container.
- Design cost-effective packaging, eg groups of students are given four table-tennis balls and need to design a box to package them that minimises the use of material.
- As designers, students are told that they have been given a square piece of metal of side length 2 metres from which to design an open rectangular water tank. The volume of water that the tank will hold depends on the size of squares cut from each of the four corners of the square piece of metal. Students choose a scale and make models of tanks and find the volume of water that they can hold. They could graph results and determine when the volume is the greatest. What happens if the side of the original square is doubled?
- Students calculate the cross-sectional area of a river, and hence calculate the flow-rate of the river.
- Students calculate the surface area and volume of sphere-shaped sweets or marshmallows (cylinder-shaped). Class results could be combined to form a data set for statistical analysis.

Discussion would include

- what assumptions are being made about the shape of the sweet?
- how to get a reasonably accurate measure for the radius?
- how accurate the results would be
- are the results normally distributed?
- what claims could the manufacturer make about the volume and surface area of that particular product?

Area of Study 4: Probability

In this Area of Study, students calculate the expected outcomes for simple experiments and compare them with experimental results, and establish the probabilities of outcomes.

Outcomes addressed

A student:

- HG1.1 uses Mathematics and statistics to evaluate and construct arguments in a range of familiar contexts
- HG1.2 analyses representations of data in order to make predictions
- HG1.3 makes predictions about everyday situations based on simple mathematical models
- HG1.10 uses mathematical argument and reasoning to evaluate conclusions drawn from other sources, communicating a position clearly to others

Content summary

- MG1.7 Multi-stage events and applications of probability

Terminology

expected outcome	probability tree diagram
experimental	simulation
financial expectation	tree diagram
financial gain	trials
financial loss	two-stage event
outcome	

Use of technology

Students design and use a spreadsheet to simulate large numbers of trials. The graphing facilities of a spreadsheet could be used to investigate the results of a simulation.

Online probability simulations could be used for the investigation of large numbers of trials.

Area of Study notes

Formulae using factorial notation are not required in this Area of Study. Probability tree diagrams can be developed as a short hand for tree diagrams in which every branch represents an equally-likely event. Using the fundamental counting principle and a tree diagram in which every branch represents an equally-likely event establishes the conceptual background for multiplying along branches of a probability tree. Simulations should be used to establish theoretical probabilities and make comparisons with large number of experimental trials.

MG1.7: Multi-stage events and applications of probability

The focus of this topic is on counting the number of outcomes for an experiment, or the number of ways in which an event can occur, and the calculation of expected outcomes from simple experiments and comparing them with experimental results. The probability of particular outcomes can then be established. Formulae using factorial notation are not required.

Outcomes addressed

HG1.1, HG1.2, HG1.3, HG1.10

Students develop the following knowledge, skills and understanding

- construction and use of a tree diagram to establish the sample space for a simple multi-stage event
 - multiplication of the number of choices at each stage to determine the number of outcomes for a multi-stage event
 - establishing that the number of ways in which n different items can be arranged is $n(n-1)(n-2)\dots \times 1$, eg the number of arrangements of four different items is $4 \times 3 \times 2 \times 1 = 24$; the number of arrangements of three different items is $3 \times 2 \times 1 = 6$
 - checking that the above results are true by listing arrangements for small numbers of items
 - use of the formula for the probability of an event to calculate the probability that a particular selection will occur
 - use of probability tree diagrams to solve problems involving two-stage events
 - calculation of the expected number of times a particular outcome would arise, given the number of trials of a simple experiment, by establishing the theoretical probability and multiplying by the number of trials
 - comparison of the above result with an experimental result
 - calculation of the financial expectation, by multiplying each financial outcome by its probability and adding the results together
- Note: A financial loss is regarded as negative.
- carrying out simulations to model events, eg tossing a coin to represent the sex of children born, with a head indicating a boy and a tail indicating a girl.

Applications and considerations

- Determine the total number of choices in a game in which six different numbers are chosen from 30.
- Selecting cards from a pack of cards, with and without replacement, could be used to investigate two-stage experiments.
- How many different ways are there of answering a four-question True/False test? Check by listing the possible responses.
- In how many ways can the names of three candidates be listed on a ballot paper? What is the possibility that a particular candidate's name will be at the top of the paper? Check by listing.
- Determine whether it is better to buy ten tickets in one lottery, or one ticket in each of ten lotteries.
- Investigate different strategies for playing party games such as 'Greedy Pig'.
- Paul plays a game involving the tossing of two coins. He gains \$5 if both coins show heads and \$1 for a head and a tail, but loses \$6 if they both show tails. What is his financial expectation for this game?

Area of Study 5: Algebra and Modelling

In this Area of Study, students develop and apply algebraic skills and techniques to construct and evaluate linear and non-linear mathematical models in a range of vocational and other practical contexts.

Outcomes addressed

A student:

- HG1.3 makes predictions about everyday situations based on simple mathematical models
- HG1.9 chooses and uses appropriate technology to organise information from a range of practical and everyday contexts
- HG1.10 uses mathematical argument and reasoning to evaluate conclusions drawn from other sources, communicating a position clearly to others

Content summary

- MG1.8 Further algebraic skills
- MG1.9 Modelling with functions

Terminology

breakeven
exponential
extrapolate
hyperbolic
interpolate

parabola
quadratic
index
inequality
cubic

Use of technology

Students will require access to appropriate technology in order to create graphs of functions, including linear, quadratic, cubic, hyperbolic, and exponential functions. The 'zoom' feature could be used to explore graphs and to find the points of intersection of graphs, for example, in break-even analysis.

Area of Study notes

Algebraic skills should be developed through vocational and other practical contexts.

MG1.8: Further algebraic skills

In this topic, students develop algebraic skills and techniques used in work-related and everyday contexts. This includes the development of competency in evaluating algebraic formulae.

Outcomes addressed

HG1.3, HG1.9, HG1.10

Students develop the following knowledge, skills and understanding

- evaluating the subject of a formula through substitution of numerical values
- establishment and application of index laws in algebraic form

$$a^m \times a^n = a^{m+n}, a^m \div a^n = a^{m-n}, (a^m)^n = a^{mn}$$

- application of index laws to simplify expressions

$$\text{eg } (2x^3)^4, 4b^4 \times \frac{1}{4}b^3, \frac{3x^4y}{6x^2y^3}, 2m^3(m^2 + 3)$$

- solving equations including the removal of brackets and an unknown in the denominator

$$\text{eg } 3(a + 7) = 28, \tan 30 = \frac{45}{h}, \frac{t}{15} - 50 = 175$$

- solving for a linear term in an equation, following substitution

$$\text{eg find } a \text{ given that } v = 10, u = 5, s = 8 \text{ and } v^2 = u^2 + 2as$$

- solving simple inequalities, eg $6a \leq 18, \frac{t}{5} \geq 4$

- representing the solutions to simple inequalities on the number line

- solving inequalities of up to three steps

$$\text{eg } 3x - 1 < 9, 2(a + 4) \geq 24, \frac{t + 4}{5} > 3$$

Note: There is no requirement to sketch the solutions.

- write appropriate inequalities for practical problems and explain the significance of the results.

Applications and considerations

- Teachers may find it necessary to revise skills from PMG12, including
 - identification and generalisation of simple linear number patterns
 - adding and subtracting like terms
 - expansion and simplification of algebraic expressions
 - factorisation of algebraic expressions
 - multiplication of algebraic terms.
- Substitution into formulae should include a variety of vocational and other practical formulae, including formulae involving variables in words

eg

$$v = u + at, C = \frac{5}{9}(F - 32), S = \frac{D}{T}, A = P(1 + r)^n, B = \frac{m}{h^2}, D = \frac{yA}{(y+12)}, D = \frac{kA}{70},$$

$$V = \frac{4}{3}\pi r^3,$$

$$BSA(m^2) = \sqrt{\frac{\text{Height (cm)} \times \text{Weight (kg)}}{3600}},$$

$$\text{Estimated Vital Lung Capacity}_{\text{females}} = BSA \times 2000,$$

$$\text{Vital Lung Capacity} = 0.041 \times \text{Height (cm)} - 0.018 \times \text{age} - 2.69,$$

$$D = \frac{mA}{150}, \text{Fried} = \frac{\text{age (in months)} \times \text{adult dosage}}{150},$$

$$\text{MHR (males)} = (220 - \text{age}) \times \text{Maximum rate (\%)}.$$

MG1.9: Modelling with functions

This topic focuses on modelling, using linear, quadratic, cubic, or exponential functions. Students learn to apply and graph these functions in vocational and other practical contexts.

Outcomes addressed

HG1.3, HG1.9, HG1.10

Students develop the following knowledge, skills and understanding

- generating tables of values and graphing linear and quadratic functions with pencil and paper
- interpretation of the point of intersection of the graphs of two linear functions drawn from practical contexts, eg 'breakeven' points
- use of graphing software to generate graphs of linear and quadratic functions
- generating tables of values and graphing quadratic functions of the form $y = ax^2 + bx + c, x \geq 0$ with pencil and paper
- from a prepared graph based on a practical context, identification of the maximum and minimum values of a quadratic function
- by completing tables of values, recognise and graph
 - $y = ax^3, x > 0$
 - $y = a^x, a > 1$
- using graphing software to generate graphs of cubic and exponential functions
- solution of problems involving cubic and exponential functions
- recognition of the limitations of models when interpolating and/or extrapolating
- using algebraic functions to model physical phenomena.

Applications and considerations

- In the teaching of break-even analysis students should learn that $\text{profit} = \text{income function} - \text{cost function}$.

The income function is a simple linear function of the form $I = mx$, where x is the number of units sold and m is the selling price per unit sold. The cost function is of the form $C = mx + b$, where x is the number of units sold, m is the cost price per unit manufactured, and b is the fixed costs of production. The point of intersection of I and C is the break-even point, eg Martha sells muffins for \$2.50 each. It costs \$1.20 to make each muffin and \$300 for the equipment needed to make the muffins. In this example the income function is $I = 2.5x$ and the cost function is $C = 1.2x + 300$. The break-even point is the solution of the equation $I = C$, which can be solved graphically or algebraically. The profit or loss can be calculated using $\text{Profit (Loss)} = \text{Income} - \text{Costs}$.

- Students construct graphs of simultaneous linear equations (eg graphs of costs and income) to solve problems involving the identification of 'break-even' points, eg finding the time when a newly-installed appliance starts to save money for a household.
- Examples for this topic:
 - Washing removes 20% of a deep stain at each wash. Show that three washes remove about half of the stain. How many washes are needed to reduce a stain to 5% of its original amount?
 - My photocopier enlarges by 150%. Can I produce a picture about twice the size of an original? Explain how this could be done.
 - The distance that an object falls (d metres) in a certain time (t seconds) is approximated by the equation $d = 5t^2$. Construct a table of values for this function by hand, and compare the results with those obtained through the use of a spreadsheet. How long does it take for an object to fall 300 metres?
- Students could draw and interpret a variety of distance/time graphs.
- Is the approximation method 'Double and add 30° for converting from Celsius to Fahrenheit always close? The formula for converting degrees Celsius to degrees Fahrenheit could be graphed, along with the formula arising from the 'rule of thumb'. This could also be investigated with a spreadsheet and/or a graphing calculator.
- On the Earth, the formula $d = 5t^2$ can be used to express the distance (d metres) that an object falls in t seconds, if air resistance can be ignored. Investigate equivalent expressions for other bodies, eg on the moon, the equation is $d = 0.8t^2$.
- Students could investigate the compound interest earned on an amount of money invested for various time periods.

Focus Study 3: Mathematics and Design

In this Focus Study, students apply, and develop further, knowledge and skills in Measurement, and Algebra and Modelling, to practical design contexts.

Prerequisite topics

MG1.5, MG1.6

Outcomes addressed

A student:

- HG1.1 uses Mathematics and statistics to evaluate and construct arguments in a range of familiar contexts
- HG1.3 makes predictions about everyday situations based on simple mathematical models
- HG1.4 analyses two-dimensional and three-dimensional models to solve practical problems
- HG1.5 interprets the results of measurements and calculations and makes judgements about reasonableness, including conversion to appropriate units
- HG1.9 chooses and uses appropriate technology to organise information from a range of practical and everyday contexts
- HG1.10 uses mathematical argument and reasoning to evaluate conclusions drawn from other sources, communicating a position clearly to others.

Content summary

- FS3.1 Geometrical skills
- FS3.2 Scale drawings and house plans
- FS3.3 Design

Terminology

end elevation	plane
focal point	projection lines
golden ratio	radial symmetry/rotational symmetry
line symmetry	ray
optical illusion	tessellation
perspective	two-dimensional (2D)
plan view	three-dimensional (3D)

Use of technology

Students should use geometric software tools (eg WinGeom) to construct two-dimensional and three-dimensional drawings and designs. Teachers should use these tools to demonstrate the geometric properties of polygons.

Focus Study notes

Students require access to geometric instruments, including a pair of compasses, protractor, and ruler. Access to house plans and other scale drawings is required in-class.

FS3.1: Geometrical skills

The principal focus of this topic is the naming, identification and sketching of two-dimensional shapes and three-dimensional objects, and the recognition of planes and particular types of lines.

Students develop the following knowledge, skills and understanding

- construction of basic geometrical shapes and identification of their properties
- sketching two-dimensional shapes and three-dimensional objects, including plan and elevation views of three-dimensional objects
- naming and identifying polygons with 3 to 12 sides
- defining and recognising planes in three-dimensional space
- recognition of parallel, perpendicular, intersecting, and skew lines, in two-dimensional shapes and three-dimensional objects, where applicable.

Applications and considerations

- Review of Stage 5 knowledge and skills should include:
 - classification and construction of triangles and quadrilaterals
 - sketching common three-dimensional objects, including rectangular and triangular prisms, cylinders, pyramids, and cones
 - recognition of common three-dimensional objects in real-life objects, eg buildings, structures, the natural world, artistic works
 - sketching plan views and elevation views of three-dimensional objects
 - use of geometrical instruments to construct parallel and perpendicular lines, bisect a line segment, construct the perpendicular bisector of a line segment, bisect an angle
 - use of geometrical instruments to construct triangles and quadrilaterals, eg construct a scalene triangle with sides of 3 cm, 5 cm, and 6 cm, or construct a kite with two internal angles of 105° .
- Students should construct the incentre and circumcentre of a triangle. The incentre is the point of intersection of the three angle bisectors of the triangle. The circumcentre is the point of intersection of the three perpendicular bisectors of the sides of the triangle. Students should verify the circumcentre by constructing the circle that touches each vertex of the triangle.
- Construction of a regular nonagon: divide 360° by 9 to obtain the angle size of 40° , with a protractor measure this angle and mark on the circumference, use a pair of compasses to mark off equal points along the circumference. Join these points.

FS3.2: Scale drawings and house plans

In this topic, students interpret and use house plans, designs and maps in the calculation of a range of measurements and the solution of related problems.

Students develop the following knowledge, skills and understanding

- using the scale on a plan, design or map, to calculate actual dimensions, and vice versa
- interpretation of common symbols and abbreviations on house plans
- interpretation of plan and elevation views to obtain internal dimensions of rooms
- interpretation of house plans and calculation of measurements from the plans
- calculation of area and volume based on information on a plan
- application of right-angled triangle trigonometry and Pythagoras' theorem to solve problems based on plans, including finding the pitch of a roof.

Applications and considerations

- Interpretation of a house plan and making calculations using information on the plan needs to include the calculation of internal dimensions of rooms. Other calculations need to include, for example, the length and cost of wood required to make a truss, and finding the length of down-pipe required for a house.
- Calculation of area and volume based on information on a plan needs to include, for example:
 - finding the area of a house to be carpeted and the cost of purchasing the carpet
 - calculate the area and cost of painting a room in a house
 - calculate the volume of the rooms in a house and then use a table to determine the correct sized air-conditioner for the house.

FS3.3: Design

In this topic, students perform a range of constructions, identify line and radial symmetry, and apply similarity in the calculation of lengths and areas. In producing particular constructions and designs, students use geometrical instruments as well as computer software.

Students develop the following knowledge, skills and understanding

- using geometrical instruments to construct regular polygons in a circle
- calculation of the internal angle of a regular polygon using $\theta = 180\left(1 - \frac{2}{n}\right)$
- construction of the incentre and circumcentre of a triangle
- enlarging and reducing plane shapes by a specified scale factor, using a ruler and a pair of compasses
- recognising and applying similarity to calculate lengths and areas of regular and irregular plane shapes
- constructing a rotation of a simple shape to a specified angle
- identification of line and radial symmetry (rotational symmetry) in common mathematical shapes, designs, art works, and architecture
- creating, with the aid of a ruler, examples of simple perspective drawings
- recognising the application of perspective in works of art, eg art from the renaissance period
- calculating the golden ratio and identifying examples of its use in art and design
- recognising and constructing simple tessellations of three kinds: regular, semi-regular, and non-regular tessellations
- constructing a simple design by hand and with technology, using common geometrical shapes.

Applications and considerations

- When constructing regular polygons, students apply the formula $\theta = 180\left(1 - \frac{2}{n}\right)$ to calculate the size of the internal angle. Alternatively, students could construct a regular polygon in a circle, using a protractor and a pair of compasses.
- Students should identify examples of architecture that are mathematically influenced, with a brief explanation of the geometrical features evident in the design.
- Students should identify examples of the golden ratio in art, nature, and architecture.
- Students can find examples of geometrical shapes and patterns in interior design.
- Students should use geometrical instruments and geometrical software tools (as described earlier to create geometrical designs, eg:

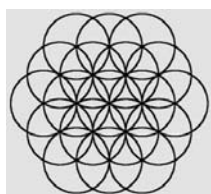

Design A



Design B

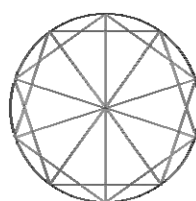

Design C

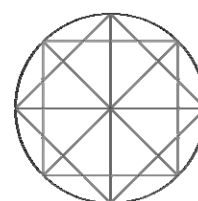

Design D

- Students need to calculate angles in designs based on circles and polygons, eg calculate the angles at each vertex in designs B, C and D above.
- Students should recognise that there are exactly three regular tessellations of the two-dimensional plane. There are only three because the size of the interior angles of the polygon must be a factor of 360° , so that the polygons can line up at the points, leaving no gaps. The three regular tessellations of the two-dimensional plane are the tessellations of the equilateral triangle, the square, and the regular hexagon.
- Non-regular tessellations may be constructed by adding and subtracting sections from the edges of a regular tessellation, eg

Construction of a non-regular tessellation

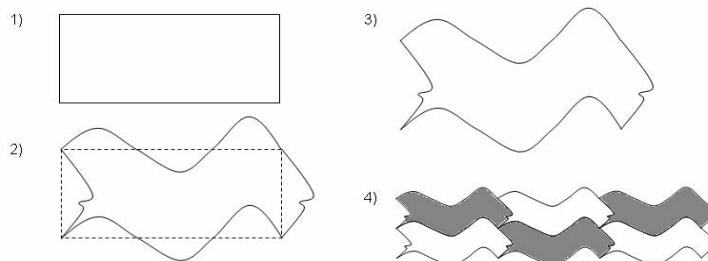

- Students verify the relationship in a tessellation that $(a - 2)(b - 2) = 4$, where a is the number of sides of a polygon and b is the number of sides of the polygon meeting at a vertex, eg for a tessellation of equilateral triangles, $a = 3$ and $b = 6$.

Focus Study 4: Mathematics and Household Finance

In this Focus Study, students apply, and develop further, knowledge and skills in Financial Mathematics, Measurement, and Algebra and Modelling, to contexts related to household finance.

Prerequisite topics

MG1.2, MG1.6

Outcomes addressed

A student:

- HG1.1 uses Mathematics and statistics to evaluate and construct arguments in a range of familiar contexts
- HG1.2 analyses representations of data in order to make predictions
- HG1.3 makes predictions about everyday situations based on simple mathematical models
- HG1.4 analyses two-dimensional and three-dimensional models to solve practical problems
- HG1.5 interprets the results of measurements and calculations and makes judgements about reasonableness, including conversion to appropriate units
- HG1.6 makes informed decisions about financial situations they are likely to encounter post-school
- HG1.9 chooses and uses appropriate technology to organise information from a range of practical and everyday contexts
- HG1.10 uses mathematical argument and reasoning to evaluate conclusions drawn from other sources, communicating a position clearly to others.

Content summary

- FS4.1 Accommodation costs: buying and renting
- FS4.2 Costs of running a household, maintenance, and repairs

Terminology

budget	public liability
building levy	reducing balance loan
consumption	renovation
conveyancing	repayment
energy rating	stamp duty
insurance	strata levy
maintenance	utilities
mortgage	

Use of technology

A spreadsheet can be used to create budgets, model home loans, and produce relevant graphical representations.

Students use online resources to compare mortgage application fees and interest rates, and to make calculations regarding repayments.

Online resources can be used to investigate energy-efficient appliances (eg shower heads and light globes) and to create visual representations of the savings.

Online calculators can be used to investigate energy efficiency and the use of heating and cooling appliances.

Students can use drawing tools to create two-dimensional and three-dimensional drawings.

Focus Study notes

Learning and assessment should draw upon and integrate the Mathematics in Areas of Study within the course, eg Data Analysis, Measurement, Probability, and Algebra and Modelling.

Teaching, learning and assessment materials should use current information from a range of sources, including, but not limited to, newspapers, journals, magazines, real bills and receipts, and the internet.

Access to examples of utility bills need to be available to students.

The decoration concepts presented in this Focus Study provides a creative application of Mathematics for those students who may enjoy design and/or construction. Some teachers may wish to combine aspects of this Focus Study with some of the knowledge and skills developed in the Mathematics and Design Focus Study.

FS4.1: Accommodation costs: buying and renting

In this topic, students calculate costs involved in purchasing and renting houses and units, and use tables and graphs that they have constructed in relation to home loans. Students also investigate changes in housing and renting costs over time and the effect of changes in interest rates.

Students develop the following knowledge, skills and understanding

- calculation of the costs involved in purchasing a house or unit, including stamp duty, mortgage application fees, and conveyancing
- calculation of the costs involved in renting a house or unit, including the cost of a rental bond
- using published tables from financial institutions to determine monthly repayments on a reducing balance home loan
- using monthly repayment tables for a home loan to calculate the total amount to be repaid and the total interest to be paid
- constructing a graph of changes in interest rates over a given period of time
- investigating the effect of changes in interest rates on the monthly repayment of a loan, using an online calculator. Results could be presented in a table or graph.
- investigating changes in the cost of housing and the cost of renting over time. Graphs of changes in interest rates over time can be constructed using line graphs or radar charts
- calculation of the depreciated value of household assets.

Applications and considerations

- Use a spreadsheet to prepare a budget for different scenarios, eg a budget for an apprentice tradesperson who is renting a city apartment, or for a young couple who have purchased their first home
- Use an online home-loan calculator to calculate repayments and total interest paid.
- Compare different home loans, including variables such as the interest rate, loan establishment costs, and early exit fees.
- Use a prepared graph of 'amount outstanding' versus 'repayment periods' to determine when a particular loan will be half-paid.
- Students should construct a graph of changes in interest rates over a given period of time and examine the results for any mathematical patterns.

FS4.2: Costs of running a household, maintenance, and repairs

The principal focus of this topic is the calculation and comparison of household running, maintenance and repair costs. Students also investigate ways to reduce household expenditure and minimise wastage.

Students develop the following knowledge, skills and understanding

- comparing the costs of various insurances, including public liability, building, contents, income protection, and personal insurance
- calculation of annual fees and levies, eg body-corporate and strata fees
- reading and interpreting common household bills, including bills for electricity, gas, telephone, council rates, land tax, and water rates
- performing calculations based on information contained in common household bills
- investigation of ways in which household expenditure can be reduced eg, efficient shower heads, more efficient light globes and appliances
- investigation of the costs of common repairs carried out by tradespeople
- performing calculations for home additions, renovations, repairs and maintenance
- constructing a scale diagram of a living area to be redecorated, eg repainting a room and replacing the floor covering, or landscaping an outdoor area
- calculation of the cost of redecorating a living area
- describing the difference between lineal metres and square metres
- calculation of the amount of material required in order to minimize wastage, eg in which direction should carpet be laid to minimise wastage and the number of joins.

Applications and considerations

- Published charts or online calculators should be used to make accurate calculations of quantities of materials required for decoration or renovation.
- Students could write a proposal to redecorate a living area, including calculations, sample colours or swatches of materials, pictures of soft furnishings and ornaments, and the total cost.
- Students can use drawing tools to construct two-dimensional and three-dimensional drawings.
- Expenses for building additions are normally quoted per square metre. Students should be aware of other costs involved in building additions, eg engineer's fees, architect's fees, council fees.
- Students could plan and cost a decoration or renovation project, including calculations for the amount and cost of materials required, eg the amount and costs of materials involved in making a mosaic pot, patchwork quilt, or a metal sculpture.

Focus Study 5: Mathematics and the Human Body

In this Focus Study, students apply, and develop further, knowledge and skills in Data Analysis, Measurement, Probability, and Algebra and Modelling, to contexts related to the human body.

Prerequisite topics

MG1.2, MG1.3, MG1.6

Outcomes addressed

A student:

- HG1.1 uses Mathematics and statistics to evaluate and construct arguments in a range of familiar contexts
- HG1.2 analyses representations of data in order to make predictions
- HG1.3 makes predictions about everyday situations based on simple mathematical models
- HG1.4 analyses two-dimensional and three-dimensional models to solve practical problems
- HG1.5 interprets the results of measurements and calculations and makes judgements about reasonableness, including conversion to appropriate units
- HG1.9 chooses and uses appropriate technology to organise information from a range of practical and everyday contexts
- HG1.10 uses mathematical argument and reasoning to evaluate conclusions drawn from other sources, communicating a position clearly to others.

Content summary

- FS5.1 Blood
- FS5.2 Body measurements
- FS5.3 Lung capacity

Terminology

biometric	line of fit
blood type	lung capacity
compatibility	normal distribution
correlation coefficient	systolic
diastolic	Theoretical Vital Lung Capacity
Estimated Vital Lung Capacity	

Use of technology

Use of appropriate technology to construct and determine the equation of a line of fit.

Use of appropriate technology to calculate the correlation coefficient.

Create a spreadsheet to calculate measures of Estimated Vital Lung Capacity.

There are many online resources for collecting statistical information for various sports.

Teachers should demonstrate the 'trendline' function on a spreadsheet and then allow students to explore the function with their own sets of data.

Focus Study notes

Learning and assessment should draw upon and integrate the Mathematics in Areas of Study within the course, eg Data Analysis, Measurement, Probability, and Algebra and Modelling.

Teaching, learning and assessment materials should use current information from a range of sources, including, but not limited to, newspapers, journals, magazines, real bills and receipts, and the internet.

There are many opportunities for the application of algebraic skills in this Focus Study. A range of formulae, other than those listed in the content, could be used, eg formulae for Body Surface Area, Targeted Heart Rate.

This Focus Study provides students with special interest in the Health Sciences, PDHPE, or Visual Arts, the opportunity to explore the Mathematics involved in those areas.

FS5.1: Blood

In this topic, students interpret charts, construct graphs and perform a range of calculations in relation to blood and heart rate. They identify trends and make predictions based on their calculations.

Students develop the following knowledge, skills and understanding

- describing heart rate as a rate expressed in beats per minute
- measuring and graphing a person's heart rate over time under different conditions, eg at rest, during exercise, and after exercise
- identifying mathematical trends in heart rate over time under different conditions
- calculating the total number of heart beats over a given time under different conditions
- calculating Targeted Heart Rate Ranges during training
- expressing blood pressure using the two measures, systolic and diastolic
- measuring blood pressure over time and under different conditions
- reading a blood pressure chart and interpreting the 'healthiness' of the measure
- interpreting data in a blood compatibility chart as an alternate presentation of data in a two-way table
- predicting, by calculation, the number of people of each blood type in a population given the percentage breakdowns. See support material.
- predicting, by calculation, the expected number of people of a particular blood type in a population.

Applications and considerations

- Students should measure and record heart rate under different conditions, eg heart rate during different exercises (could include both aerobic and non-aerobic activities), recovery rate after exercise, relationship between a person's resting heart rate and heart rate after exercise or recovery time after exercise.

Discussion should include

- are the relationships linear or non-linear?
 - expected differences between resting heart rate in non-stressful conditions versus stressful conditions
 - other measures (factors) of health that may affect heart rate.
- Calculation of ranges of Maximum Heart Rates. (See support material.)
 - Students could investigate the amount of blood pumped by the heart over time, given different exercise conditions.
 - Blood pressure graphed over time introduces the involvement of three variables. Prepared graphs could be used if measuring equipment is unavailable. (The PDHPE faculty would be a good source of assistance.) The appropriateness of different types of graphs to display this information should be discussed.
 - Graphs of heart rate and temperature over time (as used in hospitals) could be investigated if additional examples of graphs involving three variables are required.
 - Students could investigate
 - blood donation rates in different populations
 - trends in donation rates and usage at different times of the year.
 - Students should be given the opportunity to investigate non-numerical two-way tables, eg blood compatibility charts. (See support material.)
 - Students could investigate the percentages of different blood types in a range of different countries.
 - Students could make predictions about the use of blood collected, given usage statistics. They could also perform calculations in relation to the need for ongoing blood donation, given the shelf life of blood products. (See support material.)

FS5.2: Body measurements

In this topic, students construct scatterplots and lines of fit and use them to explore relationships and make predictions about body measurements. They use technology to calculate correlation coefficients and interpret the strength of association of variables.

Students develop the following knowledge, skills and understanding

Correlation

- obtaining biometric data by measuring the body and by accessing published data
- plotting body measurement data onto a scatterplot
- recognising patterns from a scatterplot of body measurements
 - whether the points appear to form a mathematical pattern
 - whether the pattern appears to be linear
- construction of a line of fit and determining the equation, by hand and by using appropriate technology
- using the equation of a line of fit to make predictions about body measurements
- recognising the practical limitations of the equation of a line of fit
- calculation of the correlation coefficient using appropriate technology (students are not required to calculate correlation coefficients by hand)
- interpreting the strength of association using a given correlation coefficient
- interpreting the sign of a given correlation coefficient
- recognising that a high degree of correlation does not necessarily imply causality.

Applications and considerations

- Students could take measurements such as arm span, height, hip height, and length of stride. It is recommended that students have access to published biometric data to provide suitable and realistic learning contexts. Comparisons could be made using parameters such as age and gender.
- The biometric data should be used to construct lines of fit and determine their equations, and determine correlation coefficients (using a spreadsheet or other appropriate technology). For example, a scatterplot of height versus arm span, height versus weight, hip height versus stride length, hand span versus height, foot length versus height, or hand span versus foot length. Gender could be added, where appropriate, as an additional variable. For example, male and female data for arm span versus height could appear on the same scatterplot but have different lines of fit.
- Predictions could be made using the line of fit, for example predicting a person's height based on their arm span or arm length. Students should assess the accuracy of the predictions by taking measurements of an individual not in the original data set and by the value of the correlation coefficient.
- Forensic science formulae for the prediction of human height based on the length of the radius bone could be investigated and a comparison made between the students' actual measurements and the value calculated from the formulae below.

$$Height_{male} = 80.405 + 3.650r$$

$$Height_{female} = 73.502 + 3.876r$$

where *Height* is in centimetres and the length of the radius bone (*r*) is in centimetres.

Various other formulae can be used to estimate height. (See support material.)

- Leonardo Da Vinci's Vitruvian theory could be investigated. (See support material.)
- Students could model the following: 'After the age of 30, the height of a person begins to decrease at the rate of approximately 0.06 cm per year.' Representations in graphical and/or equation form can then be used to make predictions about a person's height at a given age.

Other body measurements could be taken and used to investigate the Golden Ratio phi and the Fibonacci series, eg the ratio of the length of the upper arm to the length of the hand, or the measurement from navel to toe compared to the measurement from head to toe. The Golden Ratio could be introduced or further explored in the Mathematics General 1 HSC course Focus Study *Mathematics and Design*.

FS5.3: Lung capacity

In this topic, students recognise lung capacity as a volume and perform a range of related calculations. They compare estimated and theoretical values where relevant.

Students develop the following knowledge, skills and understanding

- recognising lung capacity as a volume
- calculation of a measure of Estimated Vital Lung Capacity by practical means
- converting lung capacity from cubic centimetres to litres
 $1 \text{ cm}^3 = 1 \text{ mL}$, ($= 0.001 \text{ L}$), $1000 \text{ cm}^3 = 1 \text{ L}$
- calculation of a person's Theoretical Vital Lung Capacity (in litres) using
$$\textit{Theoretical Vital Lung Capacity} = 0.041 \times \textit{Height}(\textit{cm}) - 0.018 \times \textit{age} - 2.69$$
where *Height* is measured in centimetres and *age* is measured in years
- comparing calculated values of Estimated Vital Lung Capacity with the theoretical values.

Applications and considerations

- Students should calculate practical measures of lung capacity, using a balloon.

This will require the assumption that the balloon is a sphere and the use of

the volume of a sphere formula $V = \frac{4}{3}\pi r^3$.

The limitations of this method of estimation should be explored, eg

- how can an accurate measure of the diameter of the balloon be obtained?
- is this method of estimation likely to overestimate or underestimate the vital lung capacity?
- what issues are likely to arise if the experiment is repeated with the same balloon or a balloon of a different colour?

Alternative methods could be explored, eg graphical methods for the calculation of the volume of a balloon. (See support material.)

- Explain why the variables height and age might be important factors in Theoretical Vital Lung Capacity.
- It should be noted that the Theoretical Vital Lung Capacity is expressed in litres, while the Estimated Vital Lung Capacity is calculated in cubic centimetres.
- Explain the difference between Estimated Vital Lung Capacity and Theoretical Vital Lung Capacity, as well as any limitations.
- Compare calculated values obtained using both the Estimated Vital Lung Capacity and the Theoretical Vital Lung Capacity.
- Students could identify and investigate factors affecting lung capacity, including age, gender, medical conditions such as asthma, smoking, and level of fitness. Investigations could include the collection, recording and interpretation of data to support a hypothesis.
- Students could investigate the lung capacity of elite athletes in various sports.

Focus Study 6: Mathematics and Personal Resource Usage

In this Focus Study, students apply, and develop further, knowledge and skills in Financial Mathematics, Data Analysis, Measurement, and Algebra and Modelling, to contexts involving personal resource usage.

Prerequisite topics

MG1.2, MG1.6, MG1.7

Outcomes addressed

A student:

- HG1.1 uses Mathematics and statistics to evaluate and construct arguments in a range of familiar contexts
- HG1.2 analyses representations of data in order to make predictions
- HG1.3 makes predictions about situations based on mathematical models
- HG1.4 analyses two-dimensional and three-dimensional models to solve practical problems
- HG1.5 interprets the results of measurements and calculations and makes judgements about reasonableness, including conversion to appropriate units
- HG1.7 develops and carries out statistical processes to answer questions which she/he and others have posed
- HG1.8 solves problems involving uncertainty using basic counting techniques
- HG1.9 chooses and uses appropriate technology to organise information from a range of everyday contexts
- HG1.10 uses mathematical argument and reasoning to evaluate conclusions drawn from other sources, communicating a position clearly to others

Content summary

- FS6.1 Water usage and collection
- FS6.2 Electricity
- FS6.3 Energy efficient housing

Terminology

aerial	interpretation
appliances	joule
availability	Kilolitre
BASIX	Kilowatt
catchment	Local
consumption	meteorology
conversions	orientation
efficient	resource
energy rating	stormwater
grey water	tabulate

Use of technology

Students use spreadsheets to create graphs to display two or more sets of data, eg the rainfall in Cape York compared to the rainfall in Broken Hill.

Students use spreadsheets or other appropriate software to calculate summary statistics.

Teachers and students can use the internet to obtain suitable data.

Focus Study notes

Water is an essential resource for life. In this Focus Study, students study aspects of water as a resource, including rainfall, personal water usage, and local, State and national water usage, and compare rainfall and water usage in a range of countries.

Electricity is a fundamental resource in modern life. In this Focus Study, students solve problems based on the consumption of household electricity.

FS6.1: Water usage and collection

In this topic, students interpret, make comparisons, and perform a range of calculations in relation to personal water usage.

Students develop the following knowledge, skills and understanding

- reading and interpreting a water bill
- collection, interpretation and calculation of statistics on household and personal water usage
- collection, interpretation and calculation of statistics on local rainfall
- construction and interpretation of rainfall graphs
- calculation of the volume of water collected, based on the catchment area of a roof
- calculation of a roof's catchment area that can be diverted to an installed tank or stormwater collection point
- calculation of the total volume of water held by tanks of various shapes and sizes
- comparison of the amount of water used for a household and the amount of rainfall that could be collected over a given period
- calculation of the amount of water that could be saved by initiating changes to household water use including changing fittings, recycling grey water, collecting and recycling stormwater
- investigation of grey water and its possible recycling uses
- calculation of changes to the amount of stormwater that could be collected by varying the size of a gutter.

Applications and considerations

- Determine the amount and cost of water used by various household activities, including showering and bathing, washing clothes, watering the garden, washing a car, and using a toilet.
- Students could log their water use over a one-week period and use this to estimate personal water usage and costs for longer time periods.
- Rainfall data is widely available on the internet. Useful information and data can be found at the Australian Bureau of Meteorology and Sydney Water websites.
- Students should be aware that the millimetre is the standard unit of length on building plans.
- The catchment area of a roof is the 'plan view area' of the roof and not the actual area of the roofing material. It should be noted that the roof catchment area for single storey houses is usually greater than the floor area of the building if the house has eaves.
- Students could use the following rule-of-thumb approach to estimating the collection capacity of a roof:
Every 1 mm of rain = 1 litre (L) of water per square metre (m²) of roof area and then allow for a 15% wastage factor.
- From a plan of a house students determine and justify the best possible location for a rainwater tank, taking into account the collection area of different sections of the roof, and where the recycled water is to be used.
- There are some restrictions to the collection and the uses of grey water. Students should be aware of safe grey water recycling practices. For example, grey water should not be used to water edible garden plants and it should not be stored for longer than 24 hours.
- Students investigate the possible uses of collected stormwater within the household.
- Students could create area charts of the amount of stormwater collected versus the amount of water used by the household for watering, flushing toilets, and in washing machines.
- Calculate the amount of water used by products with various ratings.

FS6.2: Electricity

The principal focus of this topic is the calculation and comparison of household electricity consumption and costs, and the calculation and interpretation of related statistics.

Students develop the following knowledge, skills and understanding

- reading and interpreting an electricity bill
- describing the watt as an SI unit of power
- calculation of costs of running different household appliances for various time periods given the power rating, usage time, and cost of power
- interpreting the energy rating of appliances and comparing running costs of different models of the same type of appliance
- calculation of the amount of electricity that could be saved by adopting energy efficient devices and strategies.

Applications and considerations

- The watt is the SI derived unit of power, equal to one joule per second. By definition power is a rate. The symbol for the watt is W.

- Examples of calculations for running costs of appliances include

1. Calculate the cost of running a 200-watt TV set for 6 hours if the average peak rate for domestic electricity is \$0.15/kWh.

Solution:

Total electricity used = $200 \times 6 = 1200$ watt-hours or 1.2 kWh.

Cost of electricity used is $1.2 \text{ kWh} \times \$0.15/\text{kWh} = \0.18 .

2. Calculate the cost of running a 2400-watt (2.4 kW) fan heater for 8 hours per day for 30 days. Assume electricity is charged at \$0.18/kWh.

Solution:

Total electricity used = $2.4 \times 8 \times 30 = 576$ kWh.

Cost is $576 \text{ kWh} \times \$0.18/\text{kWh} = \103.68 .

FS6.3: Energy efficient housing

In this topic, students interpret, make comparisons, and perform a range of calculations in relation to requirements and data relevant to energy efficient housing.

Students develop the following knowledge, skills and understanding

- investigation of Building Sustainability Index (BASIX) Certificate requirements
- identification of the issues addressed in the BASIX, eg area of site, water, thermal comfort, and energy
- calculation of the site area of a proposed development given a site plan
- calculation of the roof area from a plan
- calculation of floor area for airconditioning purposes
- calculation of garden area and lawn area, including low and high water-use areas
- calculation of the volume of a tank, swimming pool or spa
- calculation of the area of a window or glazed door from a plan
- calculation of the floor area from a plan
- measurement of wall thicknesses and heights from a plan
- measurement of the size of eaves from a plan
- calculations of the amount of roof insulation required from a plan
- determination of the orientation of windows and skylights
- determination of breeze path from a plan
- identification of types of cooling systems, eg ceiling fans, 1-phase airconditioning, 3-phase airconditioning, ducted airconditioning.

Applications and considerations

- All building plan dimensions are in millimetres.
- Teachers may wish to restrict the complexity of design of swimming pools and spas for ease of calculation, or discuss and investigate the implications of irregular-shaped pools and varying depths.
- Local information should be discussed wherever possible, eg local climate and rainfall, and types of native vegetation.
- Make calculations for a BASIX checklist including all area and volume calculations.
- Determine the orientation of the dwelling and of windows, doors and skylights, from a site plan of a proposed dwelling.
- Students use a compass to assist in determining the orientation of a dwelling or of the windows, doors and skylights. For example, the BASIX checklist provides the following.

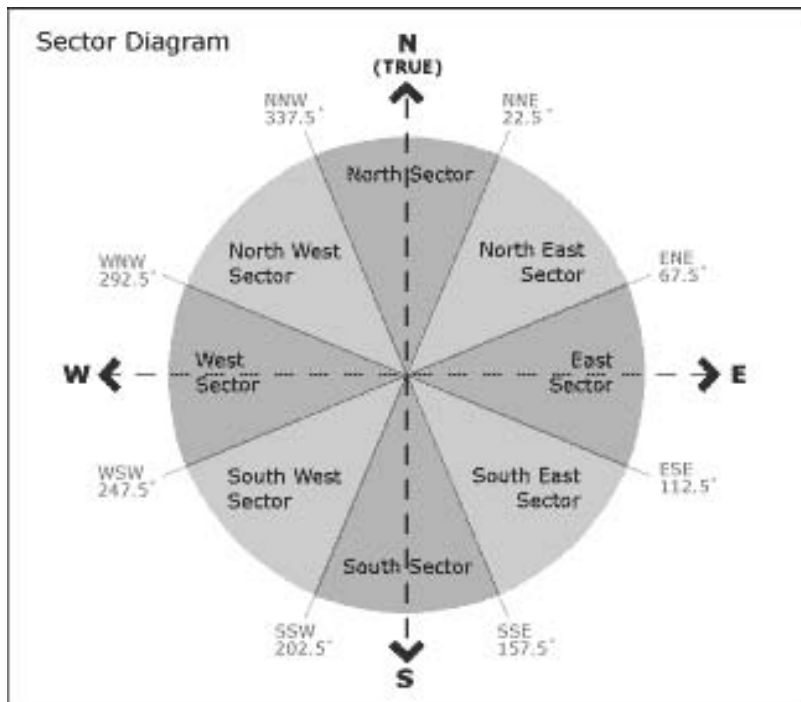

- Calculations of guttering requirements should include the lengths of downpipes.
- Design an energy efficient house for a particular building site. The plan should consider as many of the aspects of energy efficiency as possible, for example which direction the house should face to minimise cooling and heating costs, the inclusion of solar power, ceiling fans, insulation methods, rainwater collection, etc.

11 Course Requirements

Mathematics General 1 Stage 6 Syllabus includes a Preliminary course of 120 indicative hours and an HSC course of 120 indicative hours.

The Preliminary Mathematics General course (common course leading to the HSC Mathematics General 1 and HSC Mathematics General 2 courses) is constructed on the assumption that students have experienced all of the Stage 5.1 content of the *Mathematics Years 7–10 Syllabus*. Completion of the Preliminary Mathematics General course is a prerequisite for the study of the HSC Mathematics General 1 course.

Students may not study Preliminary Mathematics General or HSC Mathematics General 1 in conjunction with any other Mathematics course in Stage 6.

12 Post-school Opportunities

The study of Mathematics General 1 provides students with knowledge, skills and understanding that form a valuable foundation for a range of courses at university and other tertiary institutions.

In addition, the study of Mathematics General 1 assists students to prepare for employment and full and active participation as citizens. In particular, there are opportunities for students to gain recognition in vocational education and training. Teachers and students should be aware of these opportunities.

Recognition of Student Achievement in Vocational Education and Training (VET)

Wherever appropriate, the skills and knowledge acquired by students in their study of HSC courses should be recognised by industry and training organisations. Recognition of student achievement means that students who have satisfactorily completed HSC courses will not be required to repeat their learning in courses in TAFE NSW or other Registered Training Organisations (RTOs).

Registered Training Organisations, such as TAFE NSW, provide industry training and issue qualifications within the Australian Qualifications Framework (AQF).

The degree of recognition available to students in each subject is based on the similarity of outcomes between HSC courses and industry training packages endorsed within the AQF. Training packages are documents that link an industry's competency standards to AQF qualifications. More information about industry training packages can be found on the National Training Information Service (NTIS) website (www.ntis.gov.au).

Recognition by TAFE NSW

TAFE NSW conducts courses in a wide range of industry areas, as outlined each year in the TAFE NSW Handbook. Under current arrangements, the recognition available to students of Mathematics in relevant courses conducted by TAFE is described in the HSC/TAFE Credit Transfer Guide. This guide is produced by the Board of Studies and TAFE NSW and is distributed annually to all schools and colleges. Teachers should refer to this guide and be aware of the recognition that may be available to their students through the study of Mathematics General 1. This information can be found on the TAFE NSW website (www.tafensw.edu.au/mchoice).

Recognition by other Registered Training Organisations

Students may also negotiate recognition into a training package qualification with another Registered Training Organisation. Each student will need to provide the RTO with evidence of satisfactory achievement in Mathematics General 1 so that the degree of recognition available can be determined.

13 Assessment and Reporting

13.1 Requirements and Advice

The information in this section of the syllabus relates to the Board of Studies' requirements for assessing and reporting achievement in the Preliminary and HSC courses for the Higher School Certificate.

Assessment is the process of gathering information and making judgements about student achievement for a variety of purposes.

In the Preliminary and HSC courses those purposes include:

- assisting student learning
- evaluating and improving teaching and learning programs
- providing evidence of satisfactory achievement and completion in the Preliminary course
- providing the Higher School Certificate results.

Reporting refers to the Higher School Certificate documents that are used by the Board to report to students both the internal and external measures of achievement.

Higher School Certificate results comprise:

- an assessment mark derived from the mark submitted by the school and produced in accordance with the Board's requirements for the internal assessment program
- an examination mark derived from the HSC external examinations
- an HSC mark, which is the average of the assessment mark and the examination mark
- a performance band, determined by the HSC mark.

Results will be reported using a course report containing a performance scale with bands describing standards of achievement in the course.

The use of both internal assessment and external examination of student achievement allows measurements and observations to be made at several points and in different ways throughout the HSC Mathematics General 1 course. Taken together, the external examination and internal assessment marks provide a valid and reliable assessment of the achievement of the knowledge, understanding and skills described for each course.

The Board of Studies uses a standards-referenced approach to assessing and reporting student achievement in the Higher School Certificate.

The standards in the HSC are:

- the knowledge, skills and understanding expected to be learnt by students – the *syllabus standards*
- the levels of achievement of the knowledge, skills and understanding – the *performance standards*.

Both *syllabus standards* and *performance standards* are based on the aims, objectives, outcomes and content of a course. Together they specify what is to be learnt and how well it is to be achieved.

Teacher understanding of standards comes from the set of aims, objectives, outcomes and content in each syllabus together with:

- the performance descriptions that summarise the different levels of performance of the course outcomes
- HSC examination papers and marking guidelines
- samples of students' achievement, collected in the Standards Packages.

13.2 Internal Assessment

The internal assessment mark submitted by the school will provide a summation of each student's achievements measured at points throughout the course. The marks for each course group at a school should reflect the rank order of students and relative differences between students' achievements.

Internal assessment provides a measure of a student's achievement based on a wider range of syllabus content and outcomes than may be covered by the external examination alone. The assessment components and weightings to be applied to internal assessment are identified on pages 137 – 138. They ensure a common focus for internal assessment in the course across schools, while allowing for flexibility in the design of tasks. A variety of tasks should be used to give students the opportunity to demonstrate outcomes in different ways and to improve the validity and reliability of the assessment.

13.3 External Examination

In Mathematics General 1, the external examination consists of a written examination. The specifications for the HSC examination in Mathematics General 1 are on page 139.

The external examination provides a measure of student achievement in a range of syllabus outcomes that can be reliably measured in an examination setting.

The external examination and its marking and reporting will relate to syllabus standards by:

- providing clear links to syllabus outcomes
- enabling students to demonstrate the levels of achievement outlined in the course performance scales
- applying marking guidelines based on established criteria.

13.4 Board Requirements for the Internal Assessment Mark in Board Developed Courses

The Board requires schools to submit an assessment mark for each candidate in the Mathematics General 1 HSC course. The Board requires that the assessment tasks used to determine the internal assessment mark must comply with the components and weightings specified in the table on page 138.

The collection of information for the HSC internal assessment mark must not begin prior to the completion of the Preliminary course.

Schools are required to develop an internal assessment program that:

- specifies the various assessment tasks and the weightings allocated to each task
- provides a schedule of the tasks designed for the whole course.

The standards-referenced approach to assessment for the HSC involves schools ensuring that in the design and marking of tasks:

- assessment tasks are designed to focus on outcomes
- the types of assessment tasks are appropriate for the outcomes being assessed
- students are given the opportunity to demonstrate their level of achievement of the outcomes in a range of different task types
- tasks reflect the weightings and components specified in the relevant syllabus
- students know the assessment criteria before they begin a task
- marking guidelines for each task are linked to the standards by including the wording of syllabus outcomes and relevant performance descriptions
- marks earned on individual tasks are expressed on a scale sufficiently wide to reflect adequately the relative differences in student performances.

In feedback and reporting:

- students receive meaningful feedback about what they are able to do and what they need to do in order to improve their level of performance
- the ranking and relative differences between students result from different levels of achievement of the specified standards
- marks submitted to the Board for each course are on a scale sufficiently wide to reflect adequately the relative differences in student performances.

Note that:

- measures of objectives and outcomes that address values and attitudes should not be included in school-based assessments of students' achievements. As these objectives are important elements of any course, schools may decide to report on them separately to students and parents, perhaps using some form of descriptive statements
- measures that reflect student conduct should not be included.

13.5 Assessment Components, Weightings and Tasks

Preliminary Course

The suggested components and weightings for the Preliminary course are set out below.

Preliminary Course

Component	Description	Weighting	Suggested tasks
Concepts and techniques	Use of concepts and techniques in the solution and interpretation of mathematical problems	50%	<ul style="list-style-type: none"> • assignments • examination-style questions • multimedia-based tasks • open-book tasks
Reasoning and communication	Application of reasoning and communication in appropriate forms in the construction of mathematical arguments and the interpretation and use of mathematical models	50%	<ul style="list-style-type: none"> • oral or written reports • practical investigations or projects • practical tasks such as measurement activities • student's written explanation of problem solutions
Total:		100	

HSC Course

The mandatory components and weightings for the HSC course are set out below. The internal HSC assessment mark is to be based mainly on the Mathematics General 1 HSC course, and assessment tasks will focus on the course objectives and HSC outcomes. The Preliminary Mathematics General course will be assumed knowledge. Assessment tasks, while focusing on the Mathematics General 1 HSC outcomes, may relate to knowledge, skills and understanding from the Preliminary Mathematics General course.

Teachers can use their discretion in determining the manner in which they allocate tasks within course content. While the allocation of weightings to the various tasks set for the HSC course is left to individual schools, the percentages allocated to each syllabus component must be maintained.

It is suggested that three or four tasks are sufficient to assess the Mathematics General 1 HSC course. The range of tasks comprising the school-based assessment schedule should be varied and address the range of outcomes. One task may be used to assess several components.

HSC Course

Component	Description	Weighting	Suggested tasks
Concepts and techniques	Use of concepts and techniques in the solution and interpretation of mathematical problems	50%	<ul style="list-style-type: none"> • assignments • examination-style questions • multimedia-based tasks • open-book tasks
Reasoning and communication	Application of reasoning and communication in appropriate forms in the construction of mathematical arguments and the interpretation and use of mathematical models	50%	<ul style="list-style-type: none"> • practical investigations or projects • practical tasks such as measurement activities • student's written explanation of problem solutions
Total:		100	

13.6 HSC External Examination Specifications

The Mathematics General 1 HSC examination will consist of a written examination paper of 2½ hours duration (plus 5 minutes reading time) containing two sections with a total mark value of 100 marks. All questions in the examination are compulsory.

The examination will be based mainly on the Mathematics General 1 HSC course and will focus on the course objectives and HSC outcomes. The Preliminary Mathematics General course will be assumed knowledge for this examination. Questions focusing on Mathematics General 1 HSC outcomes may relate to knowledge, skills and understanding from the Preliminary Mathematics General course.

A formula sheet will be provided with the examination paper.

In addition to basic examination equipment, a pair of compasses, set squares, a protractor and a mathematical curve-drawing template* may be used.

Calculators that are Board-approved for the Mathematics General 1 and 2 HSC examinations may be used.

Section I (25 marks)

- Questions in this section will be in objective-response format, such as multiple-choice, multiple correct/incorrect, or other constrained response questions.
- The mark value of these questions will be one or more marks, depending on the length and demands of the question.

Section II (75 marks)

- There will be FIVE questions.
- All questions will be worth 15 marks.
- Each question will consist of a number of parts requiring free-response answers. These parts may be stand-alone questions, or may consist of several related sub-parts.

Note: Sample questions for this examination may be accessed on the Board's website (www.boardofstudies.nsw.edu.au).

* Students may take into any Mathematics examination a curve-drawing template, provided the template contains no printed formulae other than equations of simple curves (such as $y = x^2$) that may be drawn using the template.

13.7 Summary of Internal and External Assessment

Internal Assessment	Weighting	External Assessment	Weighting
Concepts and techniques	50	A written examination consisting of a range of item types.	100
Reasoning and communication	50		
	100		

13.8 Reporting Student Performance Against Standards

Student performance in an HSC course will be reported against standards on a course report. The course report includes a performance scale for the course describing levels (bands) of achievement, an HSC mark located on the performance scale, an internal assessment mark and an examination mark. It will also show, graphically, the statewide distribution of examination marks of all students in the course.

Each band on the performance scale (except for Band 1) includes descriptors that summarise the attainments typically demonstrated in that band.

The distribution of marks will be determined by students' performance against the standards and not scaled to a predetermined pattern of marks.