

B O A R D O F S T U D I E S
NEW SOUTH WALES

2008

**HIGHER SCHOOL CERTIFICATE
EXAMINATION**

Information Processes and Technology

General Instructions

- Reading time – 5 minutes
- Working time – 3 hours
- Write using black or blue pen
- Draw diagrams using pencil

Total marks – 100

Section I Pages 2–11

20 marks

- Attempt Questions 1–20
- Allow about 40 minutes for this section

Section II Pages 13–17

40 marks

- Attempt Questions 21–24
- Allow about 1 hour and 10 minutes for this section

Section III Pages 18–25

40 marks

- Attempt TWO questions from Questions 25–28
- Allow about 1 hour and 10 minutes for this section

Section I

20 marks

Attempt Questions 1–20

Allow about 40 minutes for this section

Use the multiple-choice answer sheet for Questions 1–20.

- 1 Sam is using a webcam to communicate with his friend Lee. Lee has decided to post Sam's video on a social networking site.

What should Lee do before posting the video?

- (A) Ask Sam for permission
 - (B) Edit Sam's video file
 - (C) Save a backup onto his computer
 - (D) Place a copyright symbol on the video
- 2 Which of the following contains only relational operators?
- (A) And, Or, Not
 - (B) Equals, And, Not equals
 - (C) Contains, Or, Does not contain
 - (D) Equals, Not equals, Greater than
- 3 To renew a newspaper subscription, a customer is required to visit the newspaper website, complete and submit a form.

Which information process is involved?

- (A) Collecting
- (B) Organising
- (C) Analysing
- (D) Displaying

- 4 Which tool best allows for same-time, different-place meetings?
- (A) Email
 - (B) Voicemail
 - (C) Text messaging
 - (D) Teleconferencing
- 5 Morgan sends a video file to a web-based video hosting site.
- What best describes Morgan's action?
- (A) Uploading
 - (B) Handshaking
 - (C) Downloading
 - (D) Videoconferencing
- 6 In which stage of system development would you undertake a feasibility study?
- (A) Implementing
 - (B) Making decisions
 - (C) Designing solutions
 - (D) Testing, evaluating and maintaining
- 7 When is it most appropriate to use prototyping?
- (A) When testing the final system
 - (B) When refining system requirements
 - (C) When system feasibility is being determined
 - (D) When team members disagree on what to build

8 The following diagram represents a health department's Wide Area Network (WAN).

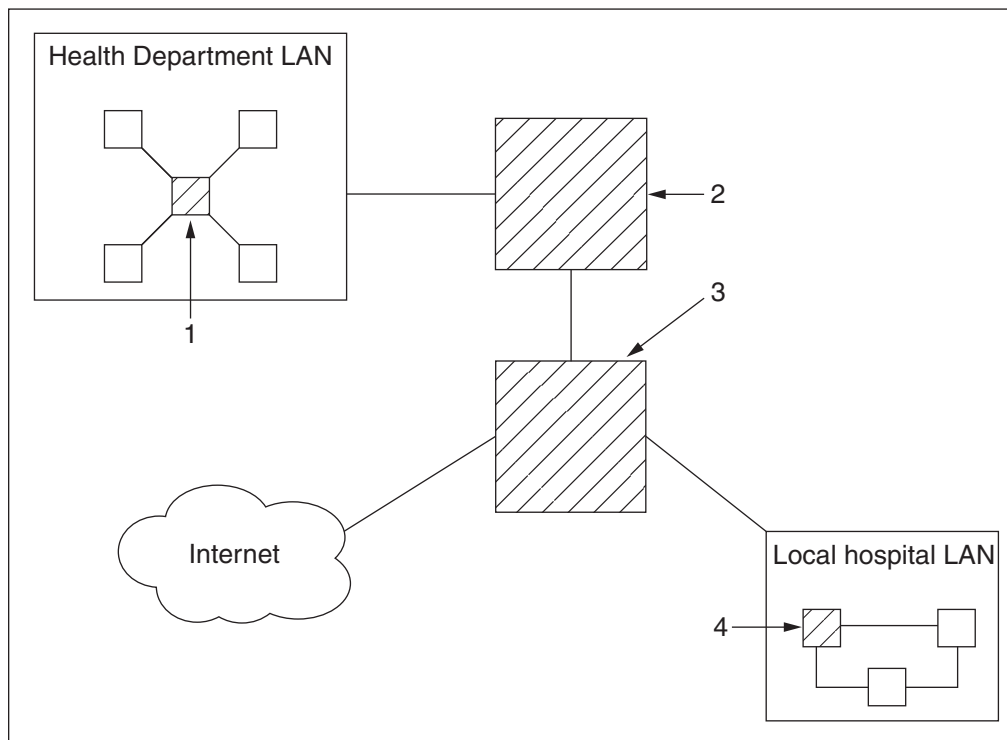

In this diagram, which device must be a router?

- (A) 1
- (B) 2
- (C) 3
- (D) 4

9 The following email message has been created:

To:	indra@gmail.com
cc:	kim@jilltech.com.au
bcc:	jordan@hotmail.com, kerry@frogpond.com
Subject:	Here is the file you requested
Attachments:	100_0949.JPG (1.45 MB)

Dear Indra,
Please find attached the file you requested.
Kind Regards
Chris

Which of the following statements is correct?

- (A) The attachment will not be received by Jordan and Kerry.
- (B) All recipients will be aware that the others have received the email and attachment.
- (C) Kerry will be aware that Jordan and Kim have also received the email and attachment.
- (D) Indra and Kim will not know that Kerry and Jordan have also received the email and attachment.

10 A database stores data about players in an Under 8 basketball team. The field for a player's date of birth only accepts dates in the form DD/MM/YYYY and does not accept dates earlier than 01/01/2000.

What are two issues addressed here?

- (A) Data integrity and the Y2K bug
- (B) Data validation and data integrity
- (C) Data redundancy and the Y2K bug
- (D) Data redundancy and data validation

- 11** A Gantt chart for an upgrade of a library network indicates that:
- Design documentation will take one week, followed by research and development which will take three weeks.
 - Designing the solution can then begin and will take two weeks.
 - Installation of cables will start immediately after this and last for one week.
 - Installation of software and hardware will last for one week and will start when research and development has concluded.
 - On completion of all of the installations, the network upgrade will undergo an evaluation for a two week period.

What is the minimum number of weeks required for the network upgrade?

- (A) 7
 - (B) 8
 - (C) 9
 - (D) 10
- 12** Which task performed by systems developers is most likely to ensure that participants accept a new system?
- (A) Interviewing the users and participants of a system to identify system requirements
 - (B) Carrying out a feasibility study looking specifically at the cost of introducing the new system
 - (C) Using a prototype to get feedback from participants before defining the system requirements
 - (D) Meeting with participants at several stages during the project to discuss training and how the systems will be implemented

- 13** A section of html code appears below:

```
<a href="kangaroos.html"> </a>
```

What does this html code allow the user to do?

- (A) Click on an icon to run a video about kangaroos
- (B) Click on a reference page and then insert an image of a kangaroo
- (C) Click on an image of a kangaroo to go to another website about kangaroos
- (D) Click on an image of a kangaroo to go to another web page about kangaroos

- 14 The following screenshot shows an advanced search using a search engine on the web.

Advanced Search

Find results with **all** of the words

with the **exact phrase**

with **at least one** of the words

without the words

Language Return pages written in

Region Search pages located in:

File Format return results of the file format

- Which of the following search expressions would match the advanced search shown?
- (A) rta licence application form pdf
 - (B) “rta form” “licence application” filetype: pdf
 - (C) rta OR form “licence application” filetype: pdf
 - (D) “licence application” AND rta form OR filetype: pdf
- 15 In October 2006, the rock band Wolfmother streamed the first live show to mobile phones. The show was encoded and compressed, then uploaded to a web server. A journalist reported that during fast sections of the guitar, the audio was distorted and broken.
- What would most likely have caused this distortion?
- (A) The speed of the server
 - (B) Electromagnetic interference
 - (C) Limitations of mobile bandwidth
 - (D) Limitations of the speakers in mobile phones

Use the table below to answer Questions 16–17.

The table shows some of the physical differences between acids, including the melting point (*MP*) and boiling point (*BP*).

Acidtbl

<i>Acid</i>	<i>State</i>	<i>Colour</i>	<i>MP</i>	<i>BP</i>	<i>Odour</i>
Oxalic	Solid	White	101	Sublimes 150	None
Citric	Solid	White	70	Decomposes	None
Acetic	Solid/liquid	Glassy	16.6	118.2	Vinegary
Butyric	Liquid	Colourless	-5.5	164.1	Rancid butter
Sulphuric	Liquid	Colourless	10.5	320	None
Nitric	Liquid	Colourless	-4.1	86	Strong
Hydrogen chloride	Gas	Colourless	-111	-84	Strong

© Science Foundation for Physics, The University of Sydney

16 Which portion of the decision tree below most clearly selects Oxalic and Citric acids?

- (A) *Colour* *Odour* *State* *MP* *Acid*
white ——— none ——— solid $\left\{ \begin{array}{l} < 100 \text{ ——— Citric} \\ > 100 \text{ ——— Oxalic} \end{array} \right.$
- (B) *Colour* *Odour* *State* *MP* *Acid*
white ——— none ——— solid $\left\{ \begin{array}{l} > 100 \text{ ——— Citric} \\ < 100 \text{ ——— Oxalic} \end{array} \right.$
- (C) *BP* *Odour* *State* *Colour* *Acid*
sublimes ———
decomposes ——— none ——— solid ——— white $\left\{ \begin{array}{l} \text{Citric} \\ \text{Oxalic} \end{array} \right.$
- (D) *BP* *Odour* *State* *Colour* *Acid*
sublimes ——— none ——— solid ——— white ——— Citric
decomposes ——— none ——— solid ——— white ——— Oxalic

17 Which SQL statement would output the following pieces of information?

Nitric, Liquid, Colourless

Hydrogen chloride, Gas, Colourless

- (A)

```
SELECT  Acid, State, Colour, Odour, MP
FROM    Acidtbl
WHERE   Odour = "Strong" AND MP > 0;
```
- (B)

```
SELECT  Acid, State, Colour, Odour, MP
FROM    Acidtbl
WHERE   Odour = "Strong" AND MP < 0;
```
- (C)

```
SELECT  Acid, State, Colour
FROM    Acidtbl
WHERE   Odour = "Strong" AND MP < 0;
```
- (D)

```
SELECT  Acid, State, Colour
FROM    Acidtbl
WHERE   Odour = "Strong" AND MP > 0;
```

Use the diagram below to answer Questions 18–19.

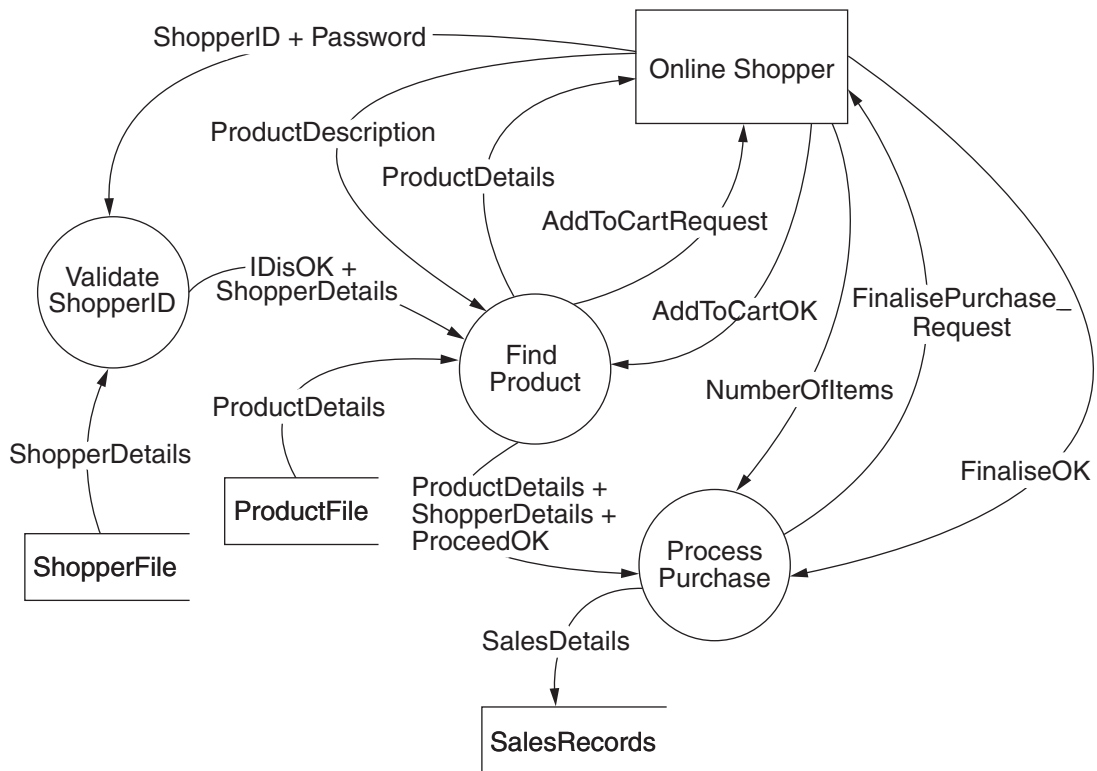

The diagram shows the dataflows involved when a shopper purchases a product online.

- 18** Which is the most likely order in which data elements are passed to the Find Product procedure?
- ProductDescription, ProductDetails, AddToCartRequest, AddToCartOK
 - AddToCartRequest, ProductDetails, ProductDescription, ShopperDetails
 - IDisOK + ShopperDetails, ProductDescription, ProductDetails, AddToCartOK
 - ShopperID + Password, IDisOK + ShopperDetails, ProductDetails, ProductDescription, AddToCartOK
- 19** Which of the following statements is FALSE?
- The Validate ShopperID procedure requires shopper details.
 - The Find Product procedure carries out analysing and collecting only.
 - The Online Shopper is the only participant represented in the diagram.
 - The Process Purchase procedure includes the information processes of storing and displaying.

- 20 A student has set up a local area network at home comprising three computers, and has connected them to the internet via a modem.

The screenshot segments represent some of the settings used in setting up one of the computers.

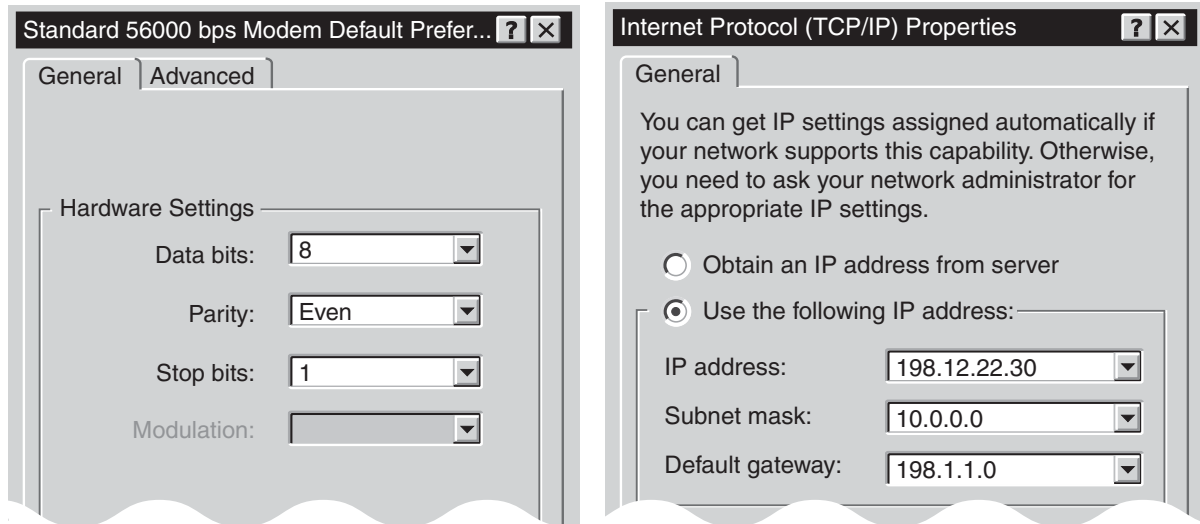

Which description best applies to this set-up and connection to the internet?

- (A) Asynchronous, error detection will NOT detect if a '1' bit has been changed to a '0' bit in the same byte, IP address is assigned manually.
- (B) Asynchronous, error detection will detect if a '1' bit has been changed to a '0' bit in the same byte, IP address is assigned manually.
- (C) Asynchronous, error detection will detect if a '1' bit has been changed to a '0' bit in the same byte, IP address is assigned automatically.
- (D) Synchronous, error detection will NOT detect if a '1' bit has been changed to a '0' bit in the same byte, IP address is assigned automatically.

BLANK PAGE

Section II

40 marks

Attempt Questions 21–24

Allow about 1 hour and 10 minutes for this section

Answer each question in the appropriate writing booklet. Extra writing booklets are available.

If you include diagrams in your answer, ensure that they are clearly labelled.

Marks

Question 21 (10 marks) Use the Question 21 Writing Booklet.

The Pet Electronic Tracking System (PETS) contains a database used to identify stray pets. Dog and cat owners can have a microchip implanted in their pets. The microchip has a unique identification number and is inserted by a vet. The vet then records the identification number, name of the pet, owner's details and whether or not a fee for this service has been paid. The vet then emails this information to PETS. An email confirmation is sent back to the vet.

(a) Draw a context diagram representing the information system for this scenario. **3**

(b) Study the following data dictionary for the PETS database. **3**

Field Name	Data Type	Data Size
ID_Number	Number	6
Pet_Name	Text	15
Owner_Last_Name	Text	15
Owner_First_Name	Text	15
Owner_Address	Text	50
Owner_Telephone_Number	Text	10
Paid	Boolean	1

Justify the choice of the **Data Type** for each of the Owner_Telephone_Number and Paid fields.

(c) The database administrator wishes to modify the database structure to include the name, address and telephone number of the vet who implants the microchip in each pet. **4**

Explain the most appropriate way to modify the database structure to include the new information. You may use a diagram to support your answer.

Question 22 (10 marks) Use the Question 22 Writing Booklet.

Winter High School is considering the implementation of the NoTruancy system, a new web-based system for monitoring student attendance. The objective of the system is to reduce problems associated with students not attending school or coming late to school. The system components are outlined below.

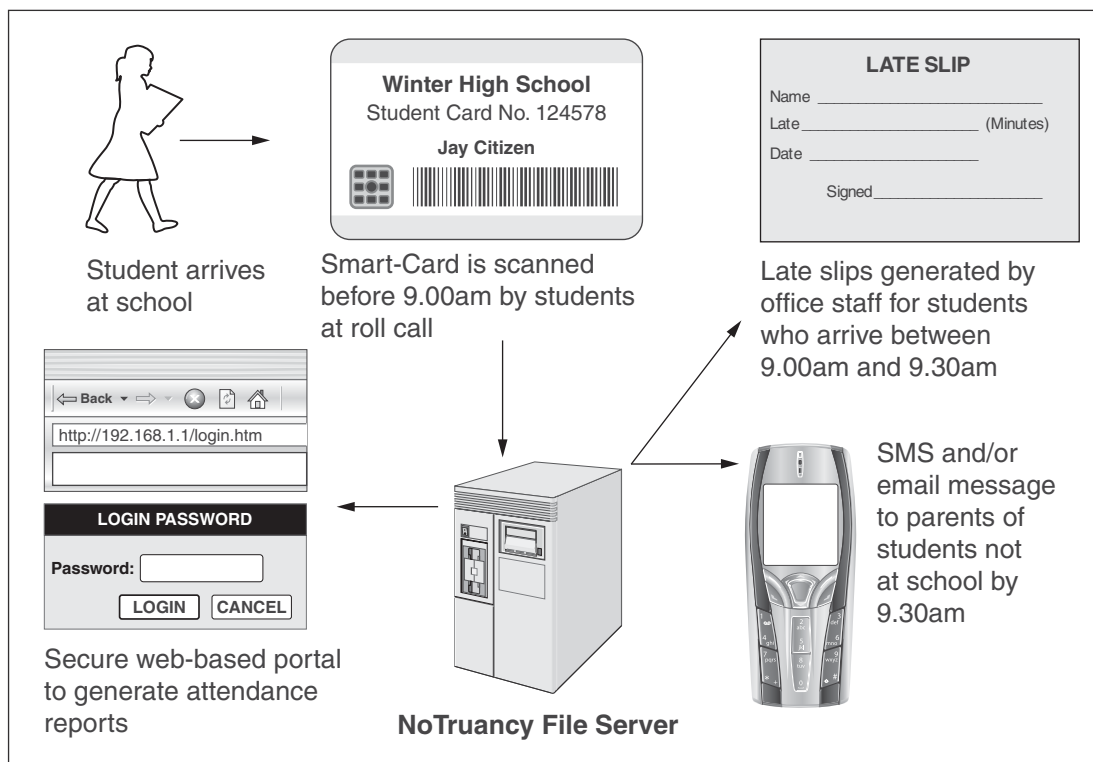

- (a) Outline a plan for training staff in the use of the system, considering: 3
- what information staff need to know
 - how training will take place
 - at what stage in the project training will take place.
- (b) Describe the tasks that will be performed by the network administrator in the operation of this system. 3
- (c) For the proposed NoTruancy System, describe an issue related to each of the following: 4
- data integrity
 - the use of the messaging system.

Question 23 (11 marks) Use the Question 23 Writing Booklet.

A group of Year 12 students wants to develop a secure social networking site that enables them to communicate once they have finished school. The site should allow students to communicate with ease, through the sharing of photos, videos and messages.

- (a) Describe TWO techniques that the website designers could use to seek ideas from the group regarding the design aspects of the site. **3**

The designers have produced the following prototype before putting the website online.

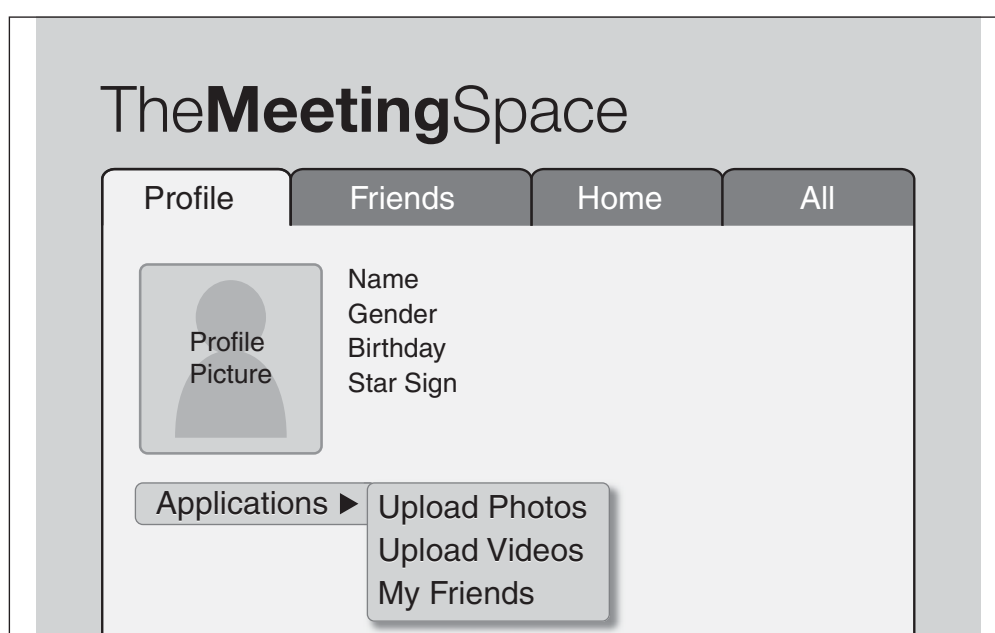

- (b) Explain whether the objectives for this website project are met by this screen design. **3**
- (c) Discuss the following issues in relation to the use of this and other social networking websites: **5**
- access
 - ownership and control of data
 - privacy principles.

Question 24 (9 marks) Use the Question 24 Writing Booklet.

Scientists have set up the Centre for Embedded Networked Systems (CENS) to collect ecological data from remote regions. Nesting boxes for birds, possums and other wildlife have been placed in trees. Each hour, sensors inside the boxes collect data and send it to a base station which is up to one kilometre away. The data collected from inside the boxes includes temperature, humidity and a still image of the occupants.

Once each day the stored data are transmitted via satellite from the base station to a national database, and then made available on a website.

Prior to the implementation of this system, park rangers manually measured the temperature and humidity in each of the regions once a day.

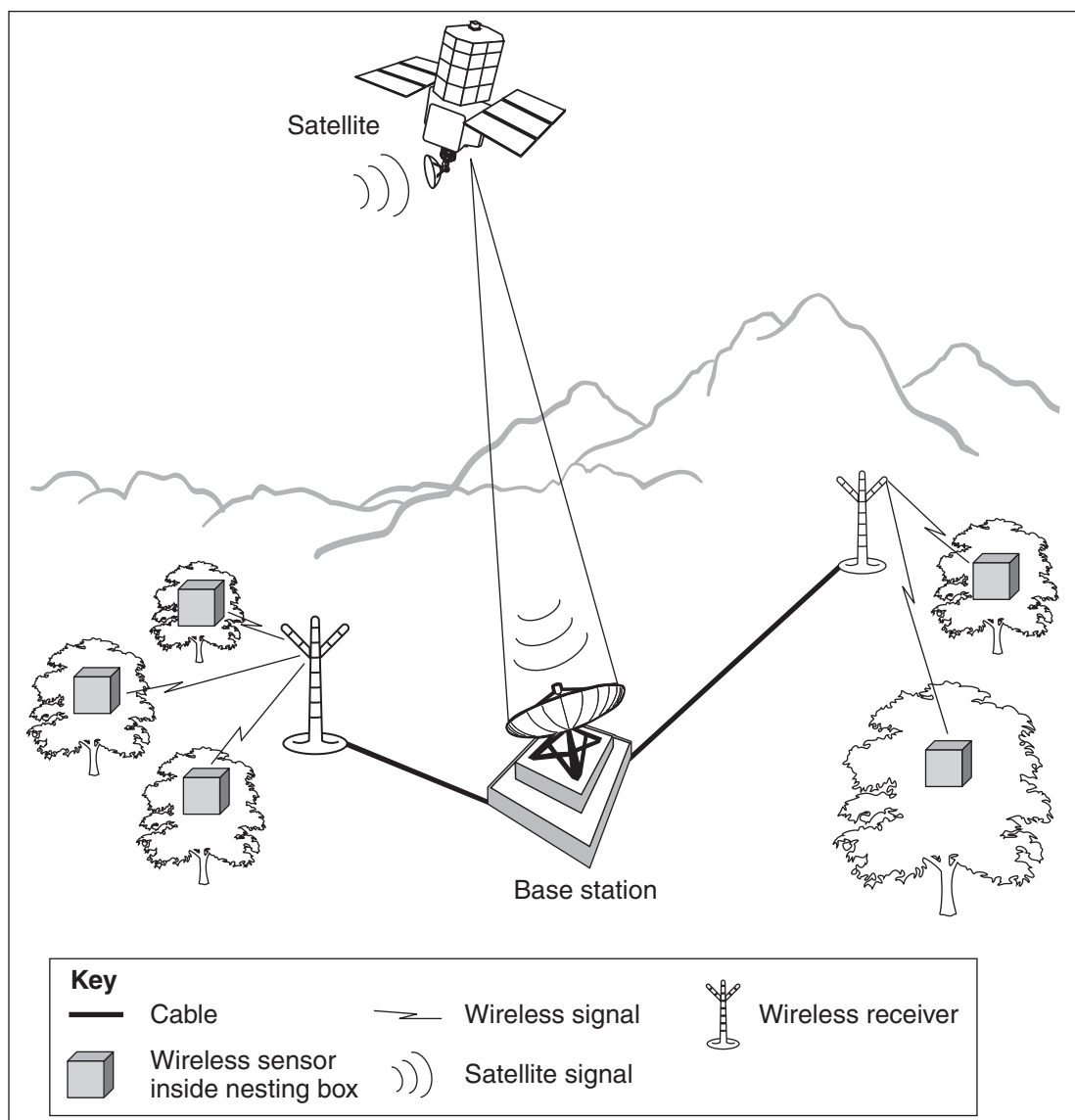

Question 24 continues on page 17

Marks

Question 24 (continued)

- (a) Evaluate the suitability of satellite and wireless technology for this system. In your answer, make reference to how these communication media work in comparison to cable media. **4**
- (b) Analyse the following issues relating to this communication system: **5**
- the change in the nature of work for the rangers
 - accessibility of data to the general public
 - the change in the nature of work for the scientists using the information.

End of Question 24

Section III

40 marks

Attempt TWO questions from Questions 25–28

Allow about 1 hour and 10 minutes for this section

Answer each question in a SEPARATE writing booklet. Extra writing booklets are available.

If you include diagrams in your answer, ensure that they are clearly labelled.

		Marks
Question 25 — Transaction Processing Systems (20 marks)		
Use a SEPARATE Writing Booklet.		
(a)	(i) Using an example, explain why transaction processing systems are easily computerised.	3
	(ii) What data/information could be recorded by a transaction processing system used to reserve concert tickets?	3

Question 25 continues on page 19

Question 25 (continued)

Use the following information to answer parts (b) and (c).

A self-checkout system has been designed for large retail stores. It allows customers to purchase and pay for goods without using a checkout operator. Transactions are completed using EFTPOS via debit or credit card. After payment, the stock database is updated for each item purchased. The features of the system are described below.

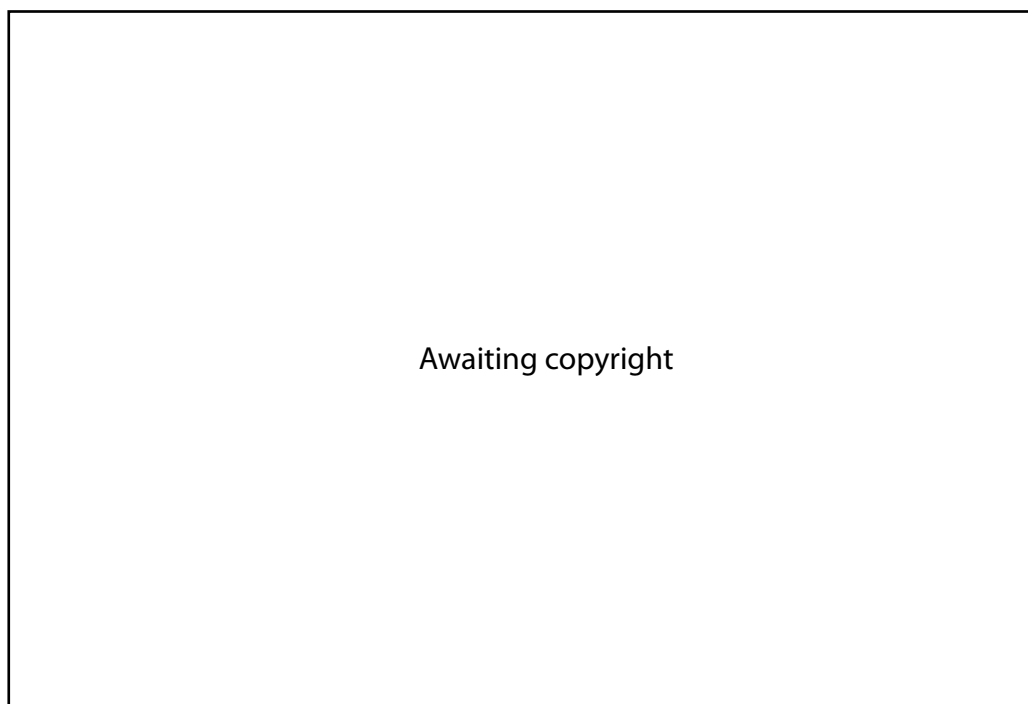

- (b) (i) Distinguish between the use of real-time processing and batch processing using an example of each within the self-checkout system. **4**
- (ii) Discuss the impact that the self-checkout system may have on customers, with reference to the following: **4**
- data accuracy
 - system failure
 - equity of access.
- (c) Analyse the data/information requirements for the self-checkout system with reference to the tasks involved in each of the following information processes: **6**
- collecting
 - analysing
 - storing and retrieving.

End of Question 25

Question 26 — Decision Support Systems (20 marks)

Use a SEPARATE Writing Booklet.

- (a) (i) Define the term *data mining* and give an example of how data mining is used to support decision making. **3**
- (ii) Describe the roles of the *knowledge engineer* in the creation of an expert system. **3**

Use the following information to answer parts (b) and (c).

Australian scientists have created an information system to assess whether or not a face is beautiful. Scientists asked 50 volunteers to rank 200 faces on a scale of 1 to 10. Based on the results, the scientists identified 14 different facial measurements that could be used to develop rules for the system. The rules were based upon ratios of these measurements. For example, they found that for a beautiful face the ratio of the length of the face to the distance from the chin to the eyes is 1.618.



Question 26 continues on page 21

Question 26 (continued)

The spreadsheet below represents a small part of the system. It shows three of the facial measurements used to calculate ratio values that are used to develop two of the rules to generate scores for each face.

	A	B	C	D	E	F	G	H	I
1		Raw Measurements			Ratios		Scores		
2	Image ID	Face Length	Chin to eyes	Eyes to top of face	RULE 1	RULE 2	Rule 1	Rule 2	Total Score
3		X	Y	Z	X:Y	Y:Z			
4	Face01	22.5	14.8	8.4	1.52	1.76	3	1	4
5	Face02	22.6	13.6	8.2	1.66	1.66	5	5	10
6	Face03	23.4	16.1	9.6	1.45	1.68	1	3	4

Shown below is another portion of the spreadsheet. It shows the upper and lower limits required to generate a score for Rule 1 and Rule 2.

	K	L	M	N
1		Lower Limit	Upper Limit	Score
2	Range 1	1.57	1.67	5
3	Range 2	1.52	1.72	3
4	Outside Range			1

- (b) (i) Generating a score for Rule 1 requires a two-step process involving formulae in cells E4 and G4. These formulae are then filled down to achieve other formulae in the spreadsheet. 4

Design formulae for E4 and G4.

- (ii) Discuss the impact this system may have on individuals assessed by the system. 4

- (c) Analyse the data/information requirements for this system with reference to the tasks involved in each of the following information processes: 6

- collecting
- organising
- analysing.

End of Question 26

Question 27 — Automated Manufacturing Systems (20 marks)

Use a SEPARATE Writing Booklet.

- (a) (i) Using an example, describe ONE reason for automation within a manufacturing system. 3
- (ii) Identify a type of sensor and describe a manufacturing situation in which it could be used. 3

Use the following information to answer parts (b) and (c).

Storage of products in warehouse

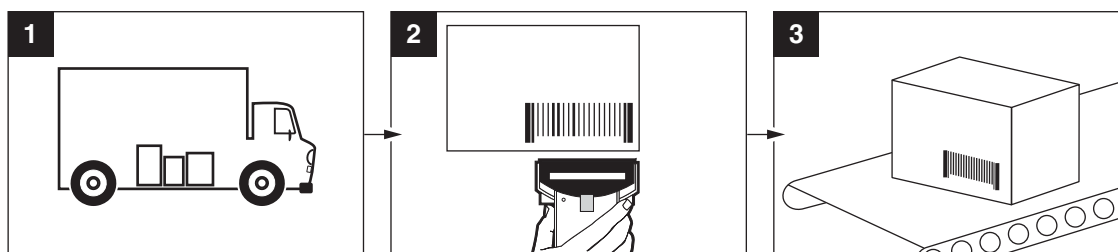

1 Products are delivered to the warehouse.

2 Products are unloaded and scanned by hand-held scanner allowing the products to be identified and tracked in the warehouse.

3 Products are placed onto conveyor belts for transport to an indexed location in the warehouse. The conveyor belts are critically damped.

Distribution of products to local shops

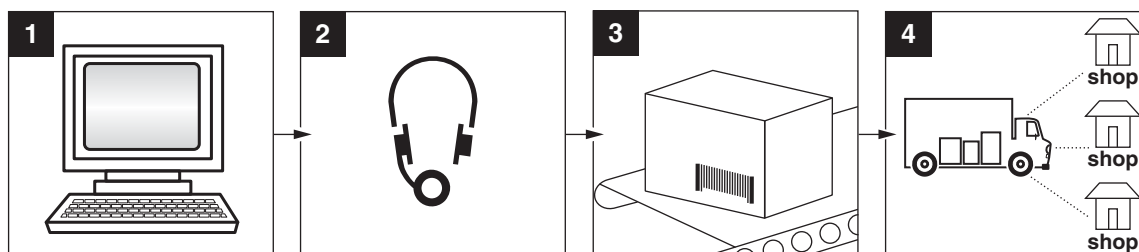

1 Shops place orders for products. These orders are received as text streams and recorded in the warehouse database.

2 The text streams are converted to digital voice streams and sent to a storeperson's headset. The voice stream includes the product code and its warehouse location.

3 The storeperson retrieves the product and places it on a conveyor belt. Voice commands are received from the storeperson confirming the process via voice recognition software.

4 Products are transported to the shops.

Question 27 continues on page 23

Question 27 (continued)

- (b) (i) After products are scanned they are placed onto conveyor belts. **4**

Justify the use of *critical damping* for the conveyor belts, with reference to *over damping* and *under damping*.

- (ii) Semi-automation has changed the nature of work. **4**

Discuss the use of semi-automation in the warehouse with reference to:

- flexibility
- common sense
- ingenuity.

- (c) Analyse the data/information requirements for this system with reference to the tasks involved in each of the following information processes: **6**

- collecting
- processing
- displaying.

End of Question 27

Question 28 — Multimedia Systems (20 marks)

Use a SEPARATE Writing Booklet.

- (a) (i) Using an example, describe ONE difference between a printed version and a multimedia version of the same information. 3

- (ii) Identify and describe TWO processing features of video production software. 3

The Video Space website allows for the hosting of videos and animations. Anyone may view the videos and animations. To share, submit and post a comment, a user must log in.

Use the screenshot shown of the Video Space homepage to answer parts (b) and (c).

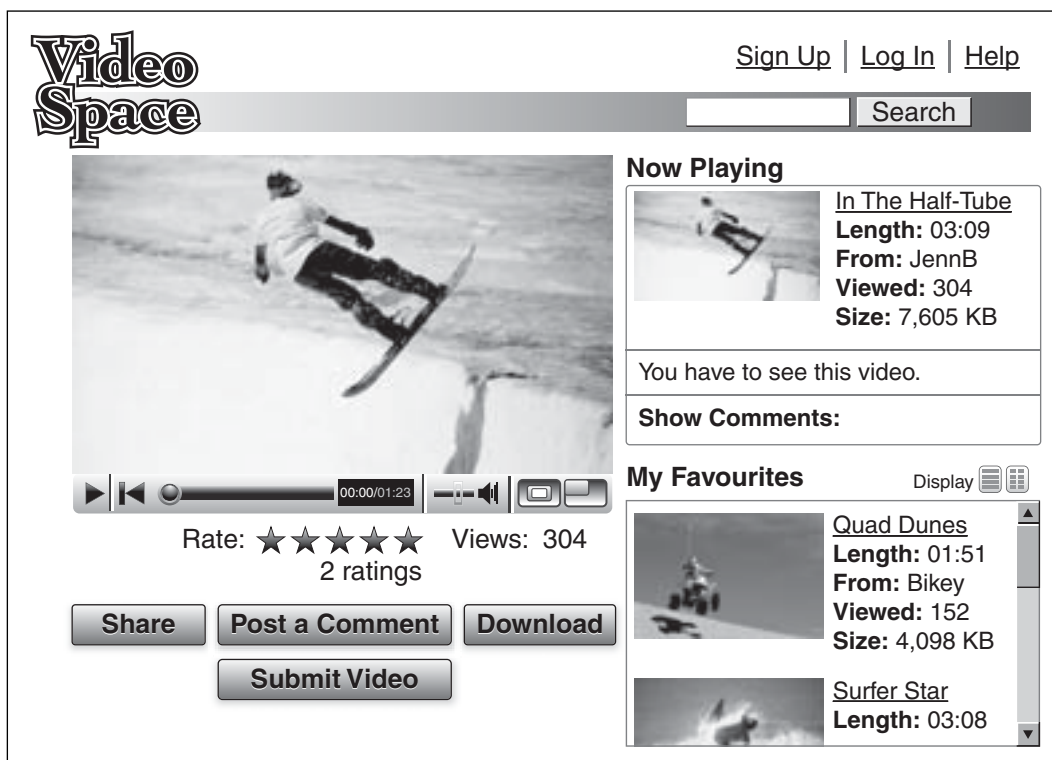

Question 28 continues on page 25

Question 28 (continued)

- (b) (i) The structure of a website can be represented as a site map, with labelled boxes representing pages connected by lines representing links. **4**

Draw a site map to represent the structure of the Video Space website.

- (ii) Discuss the use of the Video Space website, with reference to: **4**

- ease with which data can be modified
- integrity of the original source data
- the use of the internet to present information in a responsible way.

- (c) Analyse the data/information requirements for this system with reference to the tasks involved in each of the following information processes: **6**

- storing and retrieving
- processing
- displaying.

End of paper

BLANK PAGE

BLANK PAGE

BLANK PAGE