

Questions 11–16 refer to the diagram of an entertainment unit below. The unit is to be manufactured as a 'flat pack'.



Question 11 (1 mark)

Sketch a knockdown fitting that could be used.

1

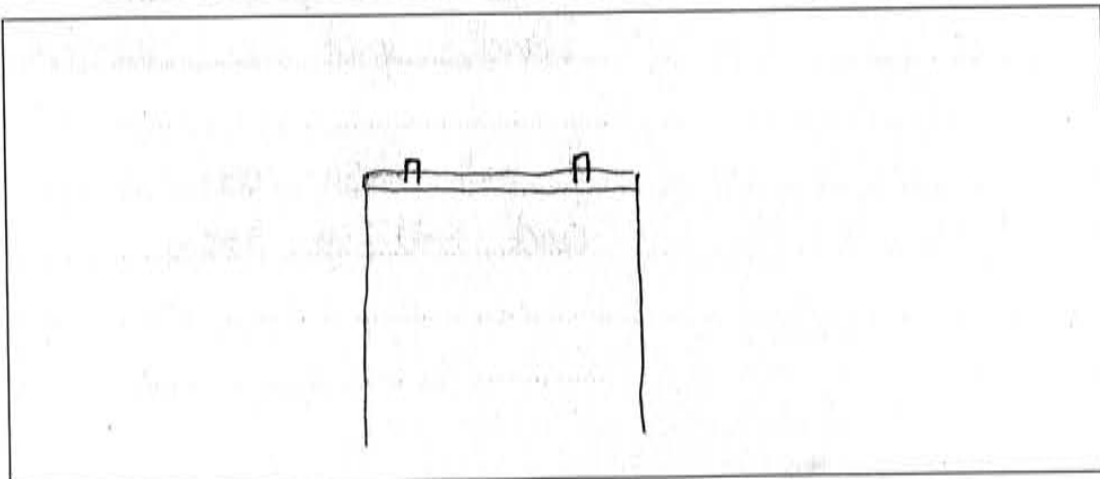

Question 12 (2 marks)

What are the advantages of producing the entertainment unit as a 'flat pack'?

2

It will be very stable and easier to put stuff
on top of it.

Question 13 (2 marks)

The details of a glass door frame from the entertainment unit are shown.

2

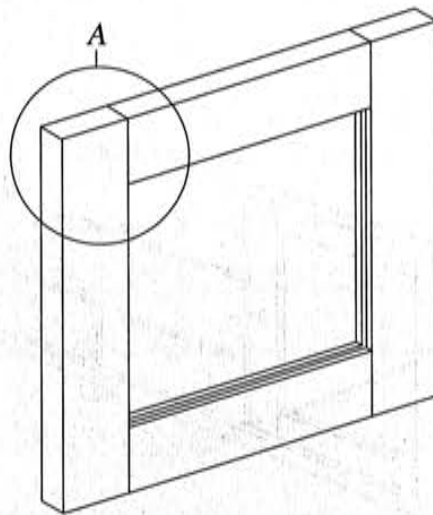

Name and describe, with the aid of sketches, a suitable framing joint that could be used in the area marked at A in the door frame.

Dowell joint.

It will finish good
and hold up strong.

Question 14 (3 marks)

Describe the safety precautions that need to be considered when constructing and finishing cabinet furniture made from manufactured boards. **3**

Need to make sure nails and/or screws are correctly inserted so it will not fall apart when used

.....

.....

.....

.....

.....

.....

.....

.....

Question 15 (3 marks)

What are the advantages and disadvantages of using solid timber as opposed to manufactured board for the top of the entertainment unit? **3**

It does not look as good and it is much more heavier.

It will hold the unit together better than manufactured board.

.....

.....

.....

.....

Question 16 (4 marks)

Describe techniques used when making furniture from manufactured boards.

4

You need to make sure its used very delicate when cut and jointed together. This will provide a better finish and ensure the project is top quality.